

**Full Environmental Assessment Form**  
**Part 1 - Project and Setting**

**Instructions for Completing Part 1**

**Part 1 is to be completed by the applicant or project sponsor.** Responses become part of the application for approval or funding, are subject to public review, and may be subject to further verification.

Complete Part 1 based on information currently available. If additional research or investigation would be needed to fully respond to any item, please answer as thoroughly as possible based on current information; indicate whether missing information does not exist, or is not reasonably available to the sponsor; and, when possible, generally describe work or studies which would be necessary to update or fully develop that information.

Applicants/sponsors must complete all items in Sections A & B. In Sections C, D & E, most items contain an initial question that must be answered either “Yes” or “No”. If the answer to the initial question is “Yes”, complete the sub-questions that follow. If the answer to the initial question is “No”, proceed to the next question. Section F allows the project sponsor to identify and attach any additional information. Section G requires the name and signature of the applicant or project sponsor to verify that the information contained in Part 1 is accurate and complete.

**A. Project and Applicant/Sponsor Information.**

Name of Action or Project: Dutchess Shepherd LLC		
Project Location (describe, and attach a general location map): 6 Mulberry Street, Rhinebeck, NY 12572		
Brief Description of Proposed Action (include purpose or need): The applicant proposes to redevelop an existing 1.43 acre lot containing a 15,554 sq. ft. historic structure into four single family homes and a 9-unit multi-family dwelling. 18 off-street parking spaces are proposed to serve the multi-family dwelling. A 4,278.3 sq. ft. portion of the existing structure would be demolished and the remainder of the existing structure would be rehabilitated.  The project requires a zoning amendment to create a new overlay district for adaptive reuse, site plan approval, demolition permit approval and subdivision approval.		
Name of Applicant/Sponsor: Dutchess Shepherd LLC		Telephone: (212) 365-1052 E-Mail: david@nava.nyc
Address: PO Box 214		
City/PO: Rhinebeck	State: NY	Zip Code: 12572
Project Contact (if not same as sponsor; give name and title/role): Victoria L. Polidoro, Esq.		Telephone: (845) 516-4323 E-Mail: vpolidoro@rodenhausenchale.com
Address: 55 Chestnut Street		
City/PO: Rhinebeck	State: NY	Zip Code: 12572
Property Owner (if not same as sponsor):		Telephone: E-Mail:
Address:		
City/PO:	State:	Zip Code:

**B. Government Approvals**

**B. Government Approvals, Funding, or Sponsorship.** (“Funding” includes grants, loans, tax relief, and any other forms of financial assistance.)

Government Entity	If Yes: Identify Agency and Approval(s) Required	Application Date (Actual or projected)
a. City Counsel, Town Board, or Village Board of Trustees <input checked="" type="checkbox"/> Yes <input type="checkbox"/> No	Village Board - Adoption of Overlay District (Local Law)	
b. City, Town or Village Planning Board or Commission <input checked="" type="checkbox"/> Yes <input type="checkbox"/> No	Planning Board - Site Plan and demolition permit	
c. City, Town or Village Zoning Board of Appeals <input checked="" type="checkbox"/> Yes <input type="checkbox"/> No	Zoning Board of Appeals - TBD	
d. Other local agencies <input type="checkbox"/> Yes <input type="checkbox"/> No		
e. County agencies <input checked="" type="checkbox"/> Yes <input type="checkbox"/> No	Department of Behavioral and Community Health	
f. Regional agencies <input type="checkbox"/> Yes <input type="checkbox"/> No		
g. State agencies <input type="checkbox"/> Yes <input type="checkbox"/> No	Department of Transportation	
h. Federal agencies <input type="checkbox"/> Yes <input type="checkbox"/> No		
i. Coastal Resources. <ul style="list-style-type: none"> <li>i. Is the project site within a Coastal Area, or the waterfront area of a Designated Inland Waterway? <input type="checkbox"/> Yes <input checked="" type="checkbox"/> No</li> <li>ii. Is the project site located in a community with an approved Local Waterfront Revitalization Program? <input type="checkbox"/> Yes <input checked="" type="checkbox"/> No</li> <li>iii. Is the project site within a Coastal Erosion Hazard Area? <input type="checkbox"/> Yes <input type="checkbox"/> No</li> </ul>		

**C. Planning and Zoning**

**C.1. Planning and zoning actions.**

Will administrative or legislative adoption, or amendment of a plan, local law, ordinance, rule or regulation be the only approval(s) which must be granted to enable the proposed action to proceed?  Yes  No

- **If Yes**, complete sections C, F and G.
- **If No**, proceed to question C.2 and complete all remaining sections and questions in Part 1

**C.2. Adopted land use plans.**

a. Do any municipally- adopted (city, town, village or county) comprehensive land use plan(s) include the site where the proposed action would be located?  Yes  No

If Yes, does the comprehensive plan include specific recommendations for the site where the proposed action would be located?  Yes  No

b. Is the site of the proposed action within any local or regional special planning district (for example: Greenway; Brownfield Opportunity Area (BOA); designated State or Federal heritage area; watershed management plan; or other?)  Yes  No

If Yes, identify the plan(s):

\_\_\_\_\_

\_\_\_\_\_

\_\_\_\_\_

c. Is the proposed action located wholly or partially within an area listed in an adopted municipal open space plan, or an adopted municipal farmland protection plan?  Yes  No

If Yes, identify the plan(s):

\_\_\_\_\_

\_\_\_\_\_

\_\_\_\_\_

**C.3. Zoning**

a. Is the site of the proposed action located in a municipality with an adopted zoning law or ordinance.  Yes  No  
If Yes, what is the zoning classification(s) including any applicable overlay district?  
R - Residential district

b. Is the use permitted or allowed by a special or conditional use permit?  Yes  No

c. Is a zoning change requested as part of the proposed action?  Yes  No  
If Yes,  
i. What is the proposed new zoning for the site? Bulkeley Schoolhouse Overlay District

**C.4. Existing community services.**

a. In what school district is the project site located? Rhinebeck Central School District

b. What police or other public protection forces serve the project site?  
Village of Rhinebeck, Dutchess County Sherriff and State Troopers

c. Which fire protection and emergency medical services serve the project site?  
Rhinebeck

d. What parks serve the project site?  
Lions Club Mini Park, Thompson Mazzarella Park, American Legion Park

**D. Project Details**

**D.1. Proposed and Potential Development**

a. What is the general nature of the proposed action (e.g., residential, industrial, commercial, recreational; if mixed, include all components)? residential

b. a. Total acreage of the site of the proposed action? 1.43 acres  
b. Total acreage to be physically disturbed? 1.4 acres  
c. Total acreage (project site and any contiguous properties) owned or controlled by the applicant or project sponsor? 1.43 acres \*See SWPPP attached as Exhibit A.

c. Is the proposed action an expansion of an existing project or use?  Yes  No  
i. If Yes, what is the approximate percentage of the proposed expansion and identify the units (e.g., acres, miles, housing units, square feet)? % \_\_\_\_\_ Units: \_\_\_\_\_

d. Is the proposed action a subdivision, or does it include a subdivision?  Yes  No  
If Yes,  
i. Purpose or type of subdivision? (e.g., residential, industrial, commercial; if mixed, specify types)  
residential  
ii. Is a cluster/conservation layout proposed?  Yes  No  
iii. Number of lots proposed? 5  
iv. Minimum and maximum proposed lot sizes? Minimum 8,115 sq. ft. Maximum 29,512 sq. ft.

e. Will the proposed action be constructed in multiple phases?  Yes  No  
i. If No, anticipated period of construction: \_\_\_\_\_ months  
ii. If Yes:  
• Total number of phases anticipated 3  
• Anticipated commencement date of phase 1 (including demolition) May month 2024 year  
• Anticipated completion date of final phase Oct month 2027 year  
• Generally describe connections or relationships among phases, including any contingencies where progress of one phase may determine timing or duration of future phases: \_\_\_\_\_  
Adaptive reuse of the former schoolhouse will occur first (18 months). Two additional phases of 2 houses each (12 months each)

f. Does the project include new residential uses?  Yes  No  
 If Yes, show numbers of units proposed.

	<u>One Family</u>	<u>Two Family</u>	<u>Three Family</u>	<u>Multiple Family (four or more)</u>
Initial Phase	_____	_____	_____	1 (9 units)
At completion of all phases	4	_____	_____	1 (9 units)

g. Does the proposed action include new non-residential construction (including expansions)?  Yes  No  
 If Yes,  
 i. Total number of structures \_\_\_\_\_  
 ii. Dimensions (in feet) of largest proposed structure: \_\_\_\_\_ height; \_\_\_\_\_ width; and \_\_\_\_\_ length  
 iii. Approximate extent of building space to be heated or cooled: \_\_\_\_\_ square feet

h. Does the proposed action include construction or other activities that will result in the impoundment of any liquids, such as creation of a water supply, reservoir, pond, lake, waste lagoon or other storage?  Yes  No  
 If Yes,  
 i. Purpose of the impoundment: \_\_\_\_\_  
 ii. If a water impoundment, the principal source of the water:  Ground water  Surface water streams  Other specify: \_\_\_\_\_  
 iii. If other than water, identify the type of impounded/contained liquids and their source. \_\_\_\_\_  
 iv. Approximate size of the proposed impoundment. Volume: \_\_\_\_\_ million gallons; surface area: \_\_\_\_\_ acres  
 v. Dimensions of the proposed dam or impounding structure: \_\_\_\_\_ height; \_\_\_\_\_ length  
 vi. Construction method/materials for the proposed dam or impounding structure (e.g., earth fill, rock, wood, concrete): \_\_\_\_\_

**D.2. Project Operations**

a. Does the proposed action include any excavation, mining, or dredging, during construction, operations, or both?  Yes  No  
 (Not including general site preparation, grading or installation of utilities or foundations where all excavated materials will remain onsite)  
 If Yes:  
 i. What is the purpose of the excavation or dredging? \_\_\_\_\_  
 ii. How much material (including rock, earth, sediments, etc.) is proposed to be removed from the site?  
 • Volume (specify tons or cubic yards): \_\_\_\_\_  
 • Over what duration of time? \_\_\_\_\_  
 iii. Describe nature and characteristics of materials to be excavated or dredged, and plans to use, manage or dispose of them. \_\_\_\_\_  
 \_\_\_\_\_  
 iv. Will there be onsite dewatering or processing of excavated materials?  Yes  No  
 If yes, describe. \_\_\_\_\_  
 \_\_\_\_\_  
 v. What is the total area to be dredged or excavated? \_\_\_\_\_ acres  
 vi. What is the maximum area to be worked at any one time? \_\_\_\_\_ acres  
 vii. What would be the maximum depth of excavation or dredging? \_\_\_\_\_ feet  
 viii. Will the excavation require blasting?  Yes  No  
 ix. Summarize site reclamation goals and plan: \_\_\_\_\_  
 \_\_\_\_\_  
 \_\_\_\_\_

b. Would the proposed action cause or result in alteration of, increase or decrease in size of, or encroachment into any existing wetland, waterbody, shoreline, beach or adjacent area?  Yes  No  
 If Yes:  
 i. Identify the wetland or waterbody which would be affected (by name, water index number, wetland map number or geographic description): \_\_\_\_\_  
 \_\_\_\_\_  
 \_\_\_\_\_

ii. Describe how the proposed action would affect that waterbody or wetland, e.g. excavation, fill, placement of structures, or alteration of channels, banks and shorelines. Indicate extent of activities, alterations and additions in square feet or acres:

\_\_\_\_\_  
\_\_\_\_\_  
\_\_\_\_\_

iii. Will the proposed action cause or result in disturbance to bottom sediments?  Yes  No

If Yes, describe: \_\_\_\_\_

iv. Will the proposed action cause or result in the destruction or removal of aquatic vegetation?  Yes  No

If Yes: \_\_\_\_\_

- acres of aquatic vegetation proposed to be removed: \_\_\_\_\_
- expected acreage of aquatic vegetation remaining after project completion: \_\_\_\_\_
- purpose of proposed removal (e.g. beach clearing, invasive species control, boat access): \_\_\_\_\_
- proposed method of plant removal: \_\_\_\_\_
- if chemical/herbicide treatment will be used, specify product(s): \_\_\_\_\_

v. Describe any proposed reclamation/mitigation following disturbance: \_\_\_\_\_

c. Will the proposed action use, or create a new demand for water?  Yes  No

If Yes: \_\_\_\_\_

i. Total anticipated water usage/demand per day: \_\_\_\_\_ 3190 gallons/day

ii. Will the proposed action obtain water from an existing public water supply?  Yes  No

If Yes: \_\_\_\_\_

- Name of district or service area: Village of Rhinebeck
- Does the existing public water supply have capacity to serve the proposal?  Yes  No
- Is the project site in the existing district?  Yes  No
- Is expansion of the district needed?  Yes  No
- Do existing lines serve the project site?  Yes  No

iii. Will line extension within an existing district be necessary to supply the project?  Yes  No

If Yes: \_\_\_\_\_

- Describe extensions or capacity expansions proposed to serve this project: N/A
- Source(s) of supply for the district: Hudson River

iv. Is a new water supply district or service area proposed to be formed to serve the project site?  Yes  No

If Yes: \_\_\_\_\_

- Applicant/sponsor for new district: \_\_\_\_\_
- Date application submitted or anticipated: \_\_\_\_\_
- Proposed source(s) of supply for new district: \_\_\_\_\_

v. If a public water supply will not be used, describe plans to provide water supply for the project: \_\_\_\_\_

vi. If water supply will be from wells (public or private), what is the maximum pumping capacity: \_\_\_\_\_ gallons/minute.

d. Will the proposed action generate liquid wastes?  Yes  No

If Yes: \_\_\_\_\_

i. Total anticipated liquid waste generation per day: \_\_\_\_\_ 3190 gallons/day

ii. Nature of liquid wastes to be generated (e.g., sanitary wastewater, industrial; if combination, describe all components and approximate volumes or proportions of each): sanitary wastewater

iii. Will the proposed action use any existing public wastewater treatment facilities?  Yes  No

If Yes: \_\_\_\_\_

- Name of wastewater treatment plant to be used: \_\_\_\_\_
- Name of district: \_\_\_\_\_
- Does the existing wastewater treatment plant have capacity to serve the project?  Yes  No
- Is the project site in the existing district?  Yes  No
- Is expansion of the district needed?  Yes  No

Yes  No  
 Yes  No  
 If Yes:
 

- Describe extensions or capacity expansions proposed to serve this project: \_\_\_\_\_

iv. Will a new wastewater (sewage) treatment district be formed to serve the project site?  Yes  No  
 If Yes:
 

- Applicant/sponsor for new district: \_\_\_\_\_
- Date application submitted or anticipated: \_\_\_\_\_
- What is the receiving water for the wastewater discharge? \_\_\_\_\_

v. If public facilities will not be used, describe plans to provide wastewater treatment for the project, including specifying proposed receiving water (name and classification if surface discharge or describe subsurface disposal plans):  
 On site septic systems \_\_\_\_\_  
 \_\_\_\_\_  
 \_\_\_\_\_

vi. Describe any plans or designs to capture, recycle or reuse liquid waste: \_\_\_\_\_  
 \_\_\_\_\_  
 \_\_\_\_\_

e. Will the proposed action disturb more than one acre and create stormwater runoff, either from new point sources (i.e. ditches, pipes, swales, curbs, gutters or other concentrated flows of stormwater) or non-point source (i.e. sheet flow) during construction or post construction?  Yes  No  
 If Yes:
 

- i. How much impervious surface will the project create in relation to total size of project parcel?  
 26,197.42 Square feet or .6014 acres (impervious surface)  
 Square feet or 1.43 acres (parcel size)
- ii. Describe types of new point sources. \_\_\_\_\_
- iii. Where will the stormwater runoff be directed (i.e. on-site stormwater management facility/structures, adjacent properties, groundwater, on-site surface water or off-site surface waters)?  
 \_\_\_\_\_  
 \_\_\_\_\_
  - If to surface waters, identify receiving water bodies or wetlands: \_\_\_\_\_
  - Will stormwater runoff flow to adjacent properties?  Yes  No
- iv. Does the proposed plan minimize impervious surfaces, use pervious materials or collect and re-use stormwater?  Yes  No

f. Does the proposed action include, or will it use on-site, one or more sources of air emissions, including fuel combustion, waste incineration, or other processes or operations?  Yes  No  
 If Yes, identify:
 

- i. Mobile sources during project operations (e.g., heavy equipment, fleet or delivery vehicles)  
 \_\_\_\_\_
- ii. Stationary sources during construction (e.g., power generation, structural heating, batch plant, crushers)  
 \_\_\_\_\_
- iii. Stationary sources during operations (e.g., process emissions, large boilers, electric generation)  
 \_\_\_\_\_

g. Will any air emission sources named in D.2.f (above), require a NY State Air Registration, Air Facility Permit, or Federal Clean Air Act Title IV or Title V Permit?  Yes  No  
 If Yes:
 

- i. Is the project site located in an Air quality non-attainment area? (Area routinely or periodically fails to meet ambient air quality standards for all or some parts of the year)  Yes  No
- ii. In addition to emissions as calculated in the application, the project will generate:
  - \_\_\_\_\_ Tons/year (short tons) of Carbon Dioxide (CO<sub>2</sub>)
  - \_\_\_\_\_ Tons/year (short tons) of Nitrous Oxide (N<sub>2</sub>O)
  - \_\_\_\_\_ Tons/year (short tons) of Perfluorocarbons (PFCs)
  - \_\_\_\_\_ Tons/year (short tons) of Sulfur Hexafluoride (SF<sub>6</sub>)
  - \_\_\_\_\_ Tons/year (short tons) of Carbon Dioxide equivalent of Hydroflouorocarbons (HFCs)
  - \_\_\_\_\_ Tons/year (short tons) of Hazardous Air Pollutants (HAPs)

h. Will the proposed action generate or emit methane (including, but not limited to, sewage treatment plants, landfills, composting facilities)?  Yes  No

If Yes:

i. Estimate methane generation in tons/year (metric): \_\_\_\_\_

ii. Describe any methane capture, control or elimination measures included in project design (e.g., combustion to generate heat or electricity, flaring): \_\_\_\_\_

---

i. Will the proposed action result in the release of air pollutants from open-air operations or processes, such as quarry or landfill operations?  Yes  No

If Yes: Describe operations and nature of emissions (e.g., diesel exhaust, rock particulates/dust): \_\_\_\_\_

---

j. Will the proposed action result in a substantial increase in traffic above present levels or generate substantial new demand for transportation facilities or services? \*See Traffic Impact Study as attached Exhibit B  Yes  No

If Yes:

i. When is the peak traffic expected (Check all that apply):  Morning  Evening  Weekend  
 Randomly between hours of \_\_\_\_\_ to \_\_\_\_\_.

ii. For commercial activities only, projected number of truck trips/day and type (e.g., semi trailers and dump trucks): \_\_\_\_\_

iii. Parking spaces: Existing 20 Proposed 27 Net increase/decrease 7

iv. Does the proposed action include any shared use parking?  Yes  No

v. If the proposed action includes any modification of existing roads, creation of new roads or change in existing access, describe: \_\_\_\_\_

vi. Are public/private transportation service(s) or facilities available within 1/2 mile of the proposed site?  Yes  No

vii. Will the proposed action include access to public transportation or accommodations for use of hybrid, electric or other alternative fueled vehicles?  Yes  No

viii. Will the proposed action include plans for pedestrian or bicycle accommodations for connections to existing pedestrian or bicycle routes?  Yes  No

---

k. Will the proposed action (for commercial or industrial projects only) generate new or additional demand for energy?  Yes  No

If Yes:

i. Estimate annual electricity demand during operation of the proposed action: \_\_\_\_\_

ii. Anticipated sources/suppliers of electricity for the project (e.g., on-site combustion, on-site renewable, via grid/local utility, or other): \_\_\_\_\_

iii. Will the proposed action require a new, or an upgrade, to an existing substation?  Yes  No

---

l. Hours of operation. Answer all items which apply.

<p>i. During Construction:</p> <ul style="list-style-type: none"> <li>• Monday - Friday: <u>see Attached Narrative re Noise</u></li> <li>• Saturday: <u>as Exhibit C</u></li> <li>• Sunday: _____</li> <li>• Holidays: _____</li> </ul>	<p>ii. During Operations:</p> <ul style="list-style-type: none"> <li>• Monday - Friday: <u>NA</u></li> <li>• Saturday: _____</li> <li>• Sunday: _____</li> <li>• Holidays: _____</li> </ul>
---	---

m. Will the proposed action produce noise that will exceed existing ambient noise levels during construction, operation, or both?  Yes  No  
 If yes:  
 i. Provide details including sources, time of day and duration:  
Temporary construction noise, See attached Exhibit C

ii. Will the proposed action remove existing natural barriers that could act as a noise barrier or screen?  Yes  No  
 Describe: \_\_\_\_\_

---

n. Will the proposed action have outdoor lighting?  Yes  No  
 If yes:  
 i. Describe source(s), location(s), height of fixture(s), direction/aim, and proximity to nearest occupied structures:  
Outdoor light fixtures will be dark-sky compliant, see attached lighting plan as Exhibit D

ii. Will proposed action remove existing natural barriers that could act as a light barrier or screen?  Yes  No  
 Describe: Additional vegetative screening is proposed

---

o. Does the proposed action have the potential to produce odors for more than one hour per day?  Yes  No  
 If Yes, describe possible sources, potential frequency and duration of odor emissions, and proximity to nearest occupied structures: \_\_\_\_\_  
 \_\_\_\_\_  
 \_\_\_\_\_

---

p. Will the proposed action include any bulk storage of petroleum (combined capacity of over 1,100 gallons) or chemical products 185 gallons in above ground storage or any amount in underground storage?  Yes  No  
 If Yes:  
 i. Product(s) to be stored \_\_\_\_\_  
 ii. Volume(s) \_\_\_\_\_ per unit time \_\_\_\_\_ (e.g., month, year)  
 iii. Generally, describe the proposed storage facilities: \_\_\_\_\_  
 \_\_\_\_\_

---

q. Will the proposed action (commercial, industrial and recreational projects only) use pesticides (i.e., herbicides, insecticides) during construction or operation?  Yes  No  
 If Yes:  
 i. Describe proposed treatment(s):  
 \_\_\_\_\_  
 \_\_\_\_\_  
 \_\_\_\_\_

ii. Will the proposed action use Integrated Pest Management Practices?  Yes  No

---

r. Will the proposed action (commercial or industrial projects only) involve or require the management or disposal of solid waste (excluding hazardous materials)?  Yes  No  
 If Yes:  
 i. Describe any solid waste(s) to be generated during construction or operation of the facility:  
 • Construction: \_\_\_\_\_ tons per \_\_\_\_\_ (unit of time)  
 • Operation : \_\_\_\_\_ tons per \_\_\_\_\_ (unit of time)  
 ii. Describe any proposals for on-site minimization, recycling or reuse of materials to avoid disposal as solid waste:  
 • Construction: \_\_\_\_\_  
 \_\_\_\_\_  
 • Operation: \_\_\_\_\_  
 \_\_\_\_\_  
 iii. Proposed disposal methods/facilities for solid waste generated on-site:  
 • Construction: \_\_\_\_\_  
 \_\_\_\_\_  
 • Operation: \_\_\_\_\_  
 \_\_\_\_\_  
 \_\_\_\_\_



s. Does the proposed action include construction or modification of a solid waste management facility?  Yes  No  
 If Yes:  
 i. Type of management or handling of waste proposed for the site (e.g., recycling or transfer station, composting, landfill, or other disposal activities): \_\_\_\_\_  
 ii. Anticipated rate of disposal/processing:  
 • \_\_\_\_\_ Tons/month, if transfer or other non-combustion/thermal treatment, or  
 • \_\_\_\_\_ Tons/hour, if combustion or thermal treatment  
 iii. If landfill, anticipated site life: \_\_\_\_\_ years

t. Will the proposed action at the site involve the commercial generation, treatment, storage, or disposal of hazardous waste?  Yes  No  
 If Yes:  
 i. Name(s) of all hazardous wastes or constituents to be generated, handled or managed at facility: \_\_\_\_\_  
 \_\_\_\_\_  
 ii. Generally describe processes or activities involving hazardous wastes or constituents: \_\_\_\_\_  
 \_\_\_\_\_  
 iii. Specify amount to be handled or generated \_\_\_\_\_ tons/month  
 iv. Describe any proposals for on-site minimization, recycling or reuse of hazardous constituents: \_\_\_\_\_  
 \_\_\_\_\_  
 v. Will any hazardous wastes be disposed at an existing offsite hazardous waste facility?  Yes  No  
 If Yes: provide name and location of facility: \_\_\_\_\_  
 \_\_\_\_\_  
 If No: describe proposed management of any hazardous wastes which will not be sent to a hazardous waste facility:  
 \_\_\_\_\_  
 \_\_\_\_\_

**E. Site and Setting of Proposed Action**

**E.1. Land uses on and surrounding the project site**

a. Existing land uses.  
 i. Check all uses that occur on, adjoining and near the project site.  
 Urban  Industrial  Commercial  Residential (suburban)  Rural (non-farm)  
 Forest  Agriculture  Aquatic  Other (specify): religious  
 ii. If mix of uses, generally describe:  
 \_\_\_\_\_  
 \_\_\_\_\_

b. Land uses and covertypes on the project site.

Land use or Covertypes	Current Acreage	Acreage After Project Completion	Change (Acres +/-)
• Roads, buildings, and other paved or impervious surfaces	.4973 ac	.6014 ac	+0.1041
• Forested	0	0	0
• Meadows, grasslands or brushlands (non-agricultural, including abandoned agricultural)			
• Agricultural (includes active orchards, field, greenhouse etc.)	0	0	0
• Surface water features (lakes, ponds, streams, rivers, etc.)	0	0	0
• Wetlands (freshwater or tidal)	0	0	0
• Non-vegetated (bare rock, earth or fill)	0	0	0
• Other Describe: _____ _____			

c. Is the project site presently used by members of the community for public recreation?  Yes  No  
i. If Yes: explain: \_\_\_\_\_

d. Are there any facilities serving children, the elderly, people with disabilities (e.g., schools, hospitals, licensed day care centers, or group homes) within 1500 feet of the project site?  Yes  No  
If Yes,  
i. Identify Facilities:  
\_\_\_\_\_

e. Does the project site contain an existing dam?  Yes  No  
If Yes:  
i. Dimensions of the dam and impoundment:  
• Dam height: \_\_\_\_\_ feet  
• Dam length: \_\_\_\_\_ feet  
• Surface area: \_\_\_\_\_ acres  
• Volume impounded: \_\_\_\_\_ gallons OR acre-feet  
ii. Dam's existing hazard classification: \_\_\_\_\_  
iii. Provide date and summarize results of last inspection:  
\_\_\_\_\_

f. Has the project site ever been used as a municipal, commercial or industrial solid waste management facility, or does the project site adjoin property which is now, or was at one time, used as a solid waste management facility?  Yes  No  
If Yes:  
i. Has the facility been formally closed?  Yes  No  
• If yes, cite sources/documentation: \_\_\_\_\_  
ii. Describe the location of the project site relative to the boundaries of the solid waste management facility:  
\_\_\_\_\_  
iii. Describe any development constraints due to the prior solid waste activities: \_\_\_\_\_

g. Have hazardous wastes been generated, treated and/or disposed of at the site, or does the project site adjoin property which is now or was at one time used to commercially treat, store and/or dispose of hazardous waste?  Yes  No  
If Yes:  
i. Describe waste(s) handled and waste management activities, including approximate time when activities occurred:  
\_\_\_\_\_  
\_\_\_\_\_

h. Potential contamination history. Has there been a reported spill at the proposed project site, or have any remedial actions been conducted at or adjacent to the proposed site?  Yes  No  
If Yes:  
i. Is any portion of the site listed on the NYSDEC Spills Incidents database or Environmental Site Remediation database? Check all that apply:  Yes  No  
 Yes – Spills Incidents database Provide DEC ID number(s): \_\_\_\_\_  
 Yes – Environmental Site Remediation database Provide DEC ID number(s): \_\_\_\_\_  
 Neither database  
ii. If site has been subject of RCRA corrective activities, describe control measures: \_\_\_\_\_  
\_\_\_\_\_

iii. Is the project within 2000 feet of any site in the NYSDEC Environmental Site Remediation database?  Yes  No  
If yes, provide DEC ID number(s): \_\_\_\_\_  
iv. If yes to (i), (ii) or (iii) above, describe current status of site(s):  
\_\_\_\_\_  
\_\_\_\_\_

v. Is the project site subject to an institutional control limiting property uses?  Yes  No

- If yes, DEC site ID number: \_\_\_\_\_
- Describe the type of institutional control (e.g., deed restriction or easement): \_\_\_\_\_
- Describe any use limitations: \_\_\_\_\_
- Describe any engineering controls: \_\_\_\_\_
- Will the project affect the institutional or engineering controls in place?  Yes  No
- Explain: \_\_\_\_\_  
 \_\_\_\_\_  
 \_\_\_\_\_

---

**E.2. Natural Resources On or Near Project Site**

a. What is the average depth to bedrock on the project site? \_\_\_\_\_ >8 feet

b. Are there bedrock outcroppings on the project site?  Yes  No  
 If Yes, what proportion of the site is comprised of bedrock outcroppings? \_\_\_\_\_ %

c. Predominant soil type(s) present on project site:

Dutchess Cardigan	_____	5 %
Haven Urban Land	_____	95 %
_____	_____	_____ %

d. What is the average depth to the water table on the project site? Average: \_\_\_\_\_ >8 feet

e. Drainage status of project site soils:  Well Drained: \_\_\_\_\_ 100 % of site  
 Moderately Well Drained: \_\_\_\_\_ % of site  
 Poorly Drained \_\_\_\_\_ % of site

f. Approximate proportion of proposed action site with slopes:  0-10%: \_\_\_\_\_ % of site  
 10-15%: \_\_\_\_\_ % of site  
 15% or greater: \_\_\_\_\_ % of site

g. Are there any unique geologic features on the project site?  Yes  No  
 If Yes, describe: \_\_\_\_\_  
 \_\_\_\_\_

h. Surface water features.

i. Does any portion of the project site contain wetlands or other waterbodies (including streams, rivers, ponds or lakes)?  Yes  No

ii. Do any wetlands or other waterbodies adjoin the project site?  Yes  No

If Yes to either *i* or *ii*, continue. If No, skip to E.2.i.

iii. Are any of the wetlands or waterbodies within or adjoining the project site regulated by any federal, state or local agency?  Yes  No

iv. For each identified regulated wetland and waterbody on the project site, provide the following information:

- Streams: Name Landsman Kill (not adjacent) Classification C(t)
- Lakes or Ponds: Name \_\_\_\_\_ Classification \_\_\_\_\_
- Wetlands: Name \_\_\_\_\_ Approximate Size \_\_\_\_\_
- Wetland No. (if regulated by DEC) \_\_\_\_\_

v. Are any of the above water bodies listed in the most recent compilation of NYS water quality-impaired waterbodies?  Yes  No  
 If yes, name of impaired water body/bodies and basis for listing as impaired: \_\_\_\_\_  
 \_\_\_\_\_

---

i. Is the project site in a designated Floodway?  Yes  No

j. Is the project site in the 100-year Floodplain?  Yes  No

k. Is the project site in the 500-year Floodplain?  Yes  No

l. Is the project site located over, or immediately adjoining, a primary, principal or sole source aquifer?  Yes  No  
 If Yes:  
 i. Name of aquifer: Principal Aquifer

m. Identify the predominant wildlife species that occupy or use the project site: squirrels _____ _____ _____	_____ _____ _____
n. Does the project site contain a designated significant natural community? <span style="float: right;"><input type="checkbox"/> Yes <input checked="" type="checkbox"/> No</span> If Yes: i. Describe the habitat/community (composition, function, and basis for designation): _____ _____ ii. Source(s) of description or evaluation: _____ iii. Extent of community/habitat: <ul style="list-style-type: none"> <li>• Currently: _____ acres</li> <li>• Following completion of project as proposed: _____ acres</li> <li>• Gain or loss (indicate + or -): _____ acres</li> </ul>	
o. Does project site contain any species of plant or animal that is listed by the federal government or NYS as endangered or threatened, or does it contain any areas identified as habitat for an endangered or threatened species? <span style="float: right;"><input checked="" type="checkbox"/> Yes <input type="checkbox"/> No</span> If Yes: i. Species and listing (endangered or threatened): _____ Northern Long-eared Bat _____ _____	
p. Does the project site contain any species of plant or animal that is listed by NYS as rare, or as a species of special concern? <span style="float: right;"><input type="checkbox"/> Yes <input checked="" type="checkbox"/> No</span> If Yes: i. Species and listing: _____ _____	
q. Is the project site or adjoining area currently used for hunting, trapping, fishing or shell fishing? <span style="float: right;"><input type="checkbox"/> Yes <input checked="" type="checkbox"/> No</span> If yes, give a brief description of how the proposed action may affect that use: _____ _____	
<b>E.3. Designated Public Resources On or Near Project Site</b>	
a. Is the project site, or any portion of it, located in a designated agricultural district certified pursuant to Agriculture and Markets Law, Article 25-AA, Section 303 and 304? <span style="float: right;"><input type="checkbox"/> Yes <input checked="" type="checkbox"/> No</span> If Yes, provide county plus district name/number: _____	
b. Are agricultural lands consisting of highly productive soils present? <span style="float: right;"><input type="checkbox"/> Yes <input checked="" type="checkbox"/> No</span> i. If Yes: acreage(s) on project site? _____ ii. Source(s) of soil rating(s): _____	
c. Does the project site contain all or part of, or is it substantially contiguous to, a registered National Natural Landmark? <span style="float: right;"><input type="checkbox"/> Yes <input checked="" type="checkbox"/> No</span> If Yes: i. Nature of the natural landmark: <input type="checkbox"/> Biological Community <input type="checkbox"/> Geological Feature ii. Provide brief description of landmark, including values behind designation and approximate size/extent: _____ _____ _____	
d. Is the project site located in or does it adjoin a state listed Critical Environmental Area? <span style="float: right;"><input type="checkbox"/> Yes <input checked="" type="checkbox"/> No</span> If Yes: i. CEA name: _____ ii. Basis for designation: _____ iii. Designating agency and date: _____	

e. Does the project site contain, or is it substantially contiguous to, a building, archaeological site, or district which is listed on the National or State Register of Historic Places, or that has been determined by the Commissioner of the NYS Office of Parks, Recreation and Historic Preservation to be eligible for listing on the State Register of Historic Places?  Yes  No  
 If Yes:  
 i. Nature of historic/archaeological resource:  Archaeological Site  Historic Building or District  
 ii. Name: Rhinebeck Village Historic District Boundary Increase  
 iii. Brief description of attributes on which listing is based: \_\_\_\_\_  
 \*See Phase 1 Report by Beth Selig as attached Exhibit E

f. Is the project site, or any portion of it, located in or adjacent to an area designated as sensitive for archaeological sites on the NY State Historic Preservation Office (SHPO) archaeological site inventory?  Yes  No

g. Have additional archaeological or historic site(s) or resources been identified on the project site?  Yes  No  
 If Yes:  
 i. Describe possible resource(s): \_\_\_\_\_  
 ii. Basis for identification: \_\_\_\_\_

h. Is the project site within five miles of any officially designated and publicly accessible federal, state, or local scenic or aesthetic resource?  Yes  No  
 If Yes:  
 i. Identify resource: \_\_\_\_\_  
 ii. Nature of, or basis for, designation (e.g., established highway overlook, state or local park, state historic trail or scenic byway, etc.): \_\_\_\_\_  
 iii. Distance between project and resource: \_\_\_\_\_ miles.

i. Is the project site located within a designated river corridor under the Wild, Scenic and Recreational Rivers Program 6 NYCRR 666?  Yes  No  
 If Yes:  
 i. Identify the name of the river and its designation: \_\_\_\_\_  
 ii. Is the activity consistent with development restrictions contained in 6NYCRR Part 666?  Yes  No

**F. Additional Information**

Attach any additional information which may be needed to clarify your project.

If you have identified any adverse impacts which could be associated with your proposal, please describe those impacts plus any measures which you propose to avoid or minimize them.

**G. Verification**

I certify that the information provided is true to the best of my knowledge.

Applicant/Sponsor Name David Ruff Date November 30th 2023

Signature  Title Member



**Disclaimer:** The EAF Mapper is a screening tool intended to assist project sponsors and reviewing agencies in preparing an environmental assessment form (EAF). Not all questions asked in the EAF are answered by the EAF Mapper. Additional information on any EAF question can be obtained by consulting the EAF Workbooks. Although the EAF Mapper provides the most up-to-date digital data available to DEC, you may also need to contact local or other data sources in order to obtain data not provided by the Mapper. Digital data is not a substitute for agency determinations.



B.i.i [Coastal or Waterfront Area]	No
B.i.ii [Local Waterfront Revitalization Area]	No
C.2.b. [Special Planning District]	Digital mapping data are not available or are incomplete. Refer to EAF Workbook.
E.1.h [DEC Spills or Remediation Site - Potential Contamination History]	Digital mapping data are not available or are incomplete. Refer to EAF Workbook.
E.1.h.i [DEC Spills or Remediation Site - Listed]	Digital mapping data are not available or are incomplete. Refer to EAF Workbook.
E.1.h.i [DEC Spills or Remediation Site - Environmental Site Remediation Database]	Digital mapping data are not available or are incomplete. Refer to EAF Workbook.
E.1.h.iii [Within 2,000' of DEC Remediation Site]	No
E.2.g [Unique Geologic Features]	No
E.2.h.i [Surface Water Features]	No
E.2.h.ii [Surface Water Features]	Yes
E.2.h.iii [Surface Water Features]	Yes - Digital mapping information on local and federal wetlands and waterbodies is known to be incomplete. Refer to EAF Workbook.
E.2.h.v [Impaired Water Bodies]	No
E.2.i. [Floodway]	No
E.2.j. [100 Year Floodplain]	No
E.2.k. [500 Year Floodplain]	No
E.2.l. [Aquifers]	Yes
E.2.l. [Aquifer Names]	Principal Aquifer
E.2.n. [Natural Communities]	No
E.2.o. [Endangered or Threatened Species]	Yes

E.2.o. [Endangered or Threatened Species - Name]	Northern Long-eared Bat
E.2.p. [Rare Plants or Animals]	No
E.3.a. [Agricultural District]	No
E.3.c. [National Natural Landmark]	No
E.3.d [Critical Environmental Area]	No
E.3.e. [National or State Register of Historic Places or State Eligible Sites]	Yes - Digital mapping data for archaeological site boundaries are not available. Refer to EAF Workbook.
E.3.e.ii [National or State Register of Historic Places or State Eligible Sites - Name]	Rhinebeck Village Historic District Boundary Increase
E.3.f. [Archeological Sites]	Yes
E.3.i. [Designated River Corridor]	No

# Exhibit A



# **Preliminary Stormwater Pollution Prevention Plan**

**Dutchess Shepard, LLC**

6 Mulberry Street  
Village of Rhinebeck

April 4, 2023  
Revised September 2, 2023



208 Creamery Road  
Hopewell Junction, NY 12533



## Table of Contents

---

1	Executive Summary .....	1
2	Project Description.....	1
2.1	Pre-Development Conditions.....	1
2.2	Post-Development Conditions .....	1
2.3	Soil Survey Data.....	2
3	Construction Sequencing.....	3
4	Erosion and Sediment Control Plan .....	3
4.1	Erosion and Sediment Control Measures .....	3
4.2	Pollution Prevention Controls .....	5
4.3	Soil Restoration .....	7
5	Stormwater Management Plan .....	7
5.1	Hydrologic Analysis .....	8
5.1.1	Rainfall Data .....	8
5.1.2	Unified Stormwater Sizing Criteria.....	9
5.1.2.1	<i>Water Quantity Control</i> .....	9
5.1.3	Comparison of Peak Discharge Rates.....	9
5.1.3.1	<i>Water Quality Treatment</i> .....	9
6	Post Construction Requirements.....	9
6.1	Inspection and Maintenance.....	9
7	Conclusion.....	11

### Tables

Table 1: USDA Soil Data.....	2
Table 2: Soil Restoration.....	7

### Appendices

A	HydroCAD Analysis
B	Soil Report
C	Rainfall Data
D	WQ <sub>v</sub> and RR <sub>v</sub> Calculations



# 1 Executive Summary

This Stormwater Pollution Prevention Plan (SWPPP) and accompanying project plans have been prepared for the construction activities associated with the Dutchess Shepard Redevelopment Project located in the Village of Rhinebeck, New York. The stormwater management, pollution prevention, and erosion and sediment control measures identified and detailed in this SWPPP and on the accompanying project plans have been designed in accordance with the requirements of the Town of Beekman and the New York State Department of Environmental Conservation (NYSDEC) State Pollutant Discharge Elimination System (SPDES) Phase II technical standards.

The proposed project:

1. Maintains the existing drainage patterns, as much as possible.
2. Controls increases in the rate of stormwater runoff resulting from the proposed development without adversely affecting adjacent or downstream properties or receiving watercourses or bodies.
3. Reducing potential stormwater quality impacts and soil erosion resulting from stormwater runoff generated both during and after construction.

The pre- and post-development stormwater runoff conditions have been reviewed and evaluated. The proposed stormwater management facilities have been designed to provide both water quality and quantity controls. Stormwater runoff will be detained, treated, and released at a rate equal to or less than that which existed prior to development of the project site.

## 2 Project Description

Dutchess Shepard, LLC is the owner of 6 Mulberry Street in the Village of Rhinebeck. The subject lot is 1.44 acres and located on the west side of Mulberry Street, south of East Market Street. The property is located in the RB-35 Zoning District. The project program includes the redevelopment of the existing site into single and multi-family residential units.

### 2.1 Pre-Development Conditions

The site is currently developed as a school which includes a 10,000 square foot building footprint, 10,000 square foot asphalt parking area, playground, and lawn areas. The building no longer functions as a school; however the gym is still used by local groups for sport activities. The building is fed by municipal water. Septic is treated with an on-site septic system.

The existing topography is generally flat. The existing drainage patterns of the project site generally drain in all directions towards the property lines. There are a few existing drainage structures that collect the parking lot and drain to the roadway drainage collection system.

There are no wetland, wetland buffers or watercourses in the vicinity of the project.

### 2.2 Post-Development Conditions

The proposed project includes the removal of the parking area, and partial demolition of the school building. The remaining portion of the building will be redeveloped into a multi-family residential



units. The remainder of the property will be subdivided to create four (4) single family lots. Each lot will have a driveway and septic system. Water service will be provided by the municipal water system. Underground infiltration system will be installed where feasible to collect and treat the runoff generated by the new road and driveway areas.

The Multi-family building will have a parking lot to the rear. Water from the 17-bedroom will be treated in an on-site septic system. Underground infiltration systems will be installed to collect and treat the stormwater runoff from the roof area and parking lot.

## 2.3 Soil Survey Data

The United States Department of Agriculture (USDA) Soil Conservation Service Soil Survey for Dutchess County was reviewed. The surficial soil conditions for the study area are shown in [Appendix B](#). The soil data for each of the soil types is summarized in [Table 1](#) below.

**Table 1: USDA Soil Data**

Map Symbol	Description	Depth to Groundwater (ft)	Depth to Bedrock (in)	Hydrologic Soil Group
DwC	Dutchess-Cardigan Complex	80”+	80”+	B
HF	Haven-Urban Land	80”+	20” to 40”	C

The Soil Conservation Service defines the hydrologic soil groups as follows:

- **Type A Soils:** Soils having a high infiltration rate and low runoff potential when thoroughly wet. These soils consist mainly of deep, well drained to excessively drained sands or gravelly sands. These soils have a high rate of water transmission.
- **Type B Soils:** Soils having a moderate infiltration rate when thoroughly wet and consists mainly of moderately deep to deep, moderately well to well drained soils with moderately fine to moderately coarse textures. These soils have a moderate rate of water transmission.
- **Type C Soils:** Soils having a low infiltration rate when thoroughly wet and consists chiefly of soils with a layer that impedes downward movement of water and soils with moderately fine-to-fine texture. These soils have a low rate of water transmission.
- **Type D Soils:** Soils having a very low infiltration rate and high runoff potential when thoroughly wet. These soils consist chiefly of clays that have high shrink-swell potential, soils that have a permanent high water table, soils that have a clay pan or clay layer at or near the surface, and soils that are shallow over nearly impervious material. These soils have a very low rate of water transmission.



### 3 Construction Sequencing

The total disturbance of the proposed project is 1.4 acres. The proposed project will be completed in Multiple phases. The construction sequencing is outlined on the accompanying plans and is provided below. The construction sequencing is as follows:

1. The Contractor shall flag the limits of disturbance prior to the commencement of construction. Bright orange construction fencing shall be used to demarcate the limits of disturbance to ensure over clearing does not occur.
2. All temporary erosion and sediment control measures (e.g., stabilized construction entrances, silt fencing, storm drain inlet protection, etc.) shall be installed as shown on the project plans. Temporary erosion and sediment control measures shall be constructed, stabilized, and functional before site disturbance begins within their tributary areas.
3. Stake out the locations of the limits of disturbance, proposed stormwater management facilities, and improvements (e.g., roadways, etc.).
4. Demolition of existing features.
5. Construction of the multi-family building and parking on Lot #3.
6. Rough grade the site. Place surplus material in the temporary soil stockpile locations shown on the project plans.
7. Develop the single-family lots as dictated by the market.
8. Finish grading and stabilize all disturbed areas. All erosion and sediment control measures must be left in place to prevent sediment from entering the stormwater practices.
9. Remove all temporary erosion and sediment control measures. Immediately stabilize the areas disturbed during their removal. Establish permanent vegetative cover.

### 4 Erosion and Sediment Control Plan

This SWPPP and accompanying project plans identify both temporary and permanent erosion and sediment control measures, which have been designed in accordance with the *New York State Standards and Specifications for Erosion and Sediment Control*, latest revision. Temporary erosion and sediment control measures will be implemented during construction to minimize soil erosion and control sediment transport off-site. Permanent erosion and sediment control measures will be implemented after construction to control the quality and quantity of stormwater runoff from the developed site.

#### 4.1 Erosion and Sediment Control Measures

Temporary erosion and sediment control measures to be utilized during construction generally include the following:



1. **Stabilized Construction Entrance** - Prior to construction, stabilized construction entrances shall be installed to reduce the tracking of sediment onto public roadways. Construction traffic must enter and exit the site at the stabilized construction entrance. The entrance shall be maintained in good condition, which will control tracking of sediment onto public rights-of-way or streets. When necessary, the placement of additional aggregate atop the filter fabric shall be done to assure the minimum thickness is maintained. All sediments and soils spilled, dropped, or washed onto the public rights-of-way must be removed immediately. Periodic inspection and needed maintenance shall be provided after each substantial rainfall event.
2. **Dust Control** - Water trucks shall be used, as needed, during construction to reduce dust generated on the site. Dust control must be provided by the general contractor to a degree that is acceptable to the owner/operator, and in compliance with the applicable local and state dust control requirements.
3. **Temporary Soil Stockpile** - Materials, such as topsoil, shall be temporarily stockpiled (if necessary) on the site during the construction process. Stockpiles shall be located in an area away from storm drainage, water bodies and/or courses, and shall be properly protected from erosion by a surrounding silt fence barrier or hay bales when located on paved areas.
4. **Silt Fencing** - Prior to the initiation of and during construction activities, silt fencing shall be established along the perimeter of all areas to be disturbed as a result of the construction which lie up gradient of water courses or adjacent properties. These barriers may extend into non-impact areas to ensure adequate protection of adjacent lands. Clearing and grubbing shall be performed only as necessary for the installation of the sediment control barrier. To ensure effectiveness of the silt fencing, daily inspections and inspections immediately after significant storm events shall be performed by site personnel. Maintenance of the fence shall be performed as needed.
5. **Temporary Seeding** - Within seven days after construction activity ceases on any particular area of the site, all disturbed areas where there shall not be construction for longer than 14 days shall be temporarily seeded and mulched to minimize erosion and sediment loss.
6. **Temporary Sediment Basin** – A temporary sediment basin shall be constructed to intercept sediment laden runoff, reduce the amount of sediment leaving the disturbed areas, and protect drainage ways, properties, and rights-of-way. Projects that have proposed stormwater ponds can be used as temporary sediment basins during construction. Temporary sediment basins shall be inspected at least every seven calendar days. All damages caused by soil erosion and construction equipment shall be repaired upon discovery. Accumulated sediment shall be removed from the sediment basin/trap when it reaches 50 percent of the design capacity and shall not exceed 50 percent. Sediment shall not be placed downstream from the embankment, adjacent to a stream, or floodplain.
7. **Dewatering** - Dewatering, if required, shall not be discharged directly into wetlands, water courses, water bodies, and storm sewer systems. Proper methods and devices shall be utilized to the extent permitted by law, such as pumping water into temporary sediment basins, providing surge protection at the inlet and outlet of pumps, floating the intake of the pump, or other methods to minimize and retain the suspended solids.



Permanent erosion and sediment control measures to be utilized after construction generally include the following:

1. **Establishment of Permanent Vegetation** - Disturbed areas that are not covered by impervious surfaces shall be seeded in accordance with the accompanying plans. The type of seed, mulch, and maintenance measures shall be followed. All areas at final grade shall be seeded and mulched within seven (7) days after completion of the major construction activity. All seeded areas shall be protected with mulch and/or hay. Final site stabilization is achieved when all soil-disturbing activities at the site has been completed and a uniform, perennial vegetative cover with a density of 80 percent has been established or equivalent stabilization measures (such as the use of mulches or geotextiles) have been employed on all unpaved areas and areas not covered by permanent structures.
2. **Final Seeding and Planting** - Final seeding and planting shall be installed as shown on the accompanying plans. Final seeding and planting will help minimize erosion and sediment loss.
3. **Rock Outlet Protection** - Rock outlet protection shall be installed at the locations as shown on the accompanying plans. The installation of rock outlet protection will reduce the depth, velocity, and energy of water, such that the flow will not erode the receiving water course or water body.

Specific erosion and sediment control measures, inspection frequency, and remediation procedures are provided in the subsequent sections and on the accompanying project plans.

## 4.2 Pollution Prevention Controls

Good housekeeping practices are designed to maintain a clean and orderly work environment. Good housekeeping measures shall be maintained throughout the construction process by those parties involved with the direct care and development of the site. The following measures should be implemented to control the possible exposure of harmful substances and materials to stormwater runoff:

1. Material resulting from the clearing and grubbing operation shall be stockpiled away from storm drainage, water bodies and/or watercourses and surrounded with adequate erosion and sediment control measures. Soil stockpile locations shall be exposed no longer than 14 days before seeding.
2. Equipment maintenance areas shall be protected from stormwater flows and shall be supplied with appropriate waste receptacles for spent chemicals, solvents, oils, greases, gasoline, and any pollutants that might contaminate the surrounding habitat and/or water supply. Equipment wash-down zones shall be located within areas draining to sediment control devices.
3. The use of detergents for large-scale (i.e., vehicles, buildings, pavement surfaces, etc.) washing is prohibited.



4. Material storage locations and facilities (i.e., covered storage areas, storage sheds, etc.) shall be located onsite and shall be stored according to the manufacturer's standards in a dedicated staging area. Chemicals, paints, solvents, fertilizers, and other toxic material must be stored in waterproof containers. Runoff containing such materials must be collected, removed from the site, treated and disposed at an approved solid waste or chemical disposal facility.
5. Hazardous spills shall be immediately contained to prevent pollutants from entering the surrounding habitat and/or water supply. Spill Kits shall be provided onsite and shall be displayed in a prominent location for ease of access and use. Spills greater than five (5) gallons shall be reported to the NYSDEC Response Unit at 1-800-457-7362. In addition, a record of the incident(s) and/or notifications shall be documented and attached to the SWPPP.
6. Portable sanitary waste facilities shall be provided onsite for workers and shall be properly maintained.
7. Dumpsters and/or debris containers shall be located onsite and shall be of adequate size to manage respective materials. Regular collection and disposal of wastes shall occur as required.
8. Temporary concrete washout facilities should be located a minimum of 50 feet from storm drain inlets, open drainage facilities, and watercourses. Each facility should be located away from construction traffic or access areas to prevent disturbance or tracking. A sign should be installed adjacent to each washout facility to inform concrete equipment operators to utilize the proper facilities. When temporary concrete washout facilities are no longer required for the work, the hardened concrete shall be removed and disposed of. Materials used to construct the temporary concrete washout facilities shall be removed and disposed of. Holes, depressions or other ground disturbance caused by the removal of the temporary concrete washout facilities shall be backfilled and/or repaired, seeded, and mulched for final stabilization.
9. Non-stormwater components of site discharge must be clean water. Water used for construction, which discharges from the site, must originate from a public water supply or private well approved by the Health Department. Water used for construction that does not originate from an approved public supply must not discharge from the site. It can be retained in the ponds until it infiltrates and evaporates.





### 4.3 Soil Restoration

The soils within in the limits of disturbance are Type A soils. In accordance with Table 5.3 of the *New York State Stormwater Management Design Manual*, the soils shall be restored as outlined in Table 2 below:

**Table 2: Soil Restoration**

Type of Soil Disturbance	Soil Restoration Requirement	Comment
No soil disturbance (preservation of natural features)	Restoration not permitted	Protect from any ongoing construction activity
Minimal soil disturbance	Restoration not permitted	Clearing and grubbing activities
Areas where topsoil is stripped only (no change in grade)	Apply 6” of topsoil	Protect from any ongoing construction activity
Areas of cut or fill	Aerate and apply 6” of topsoil	Aeration includes the use of machines such as tractor-drawn implements with coulters making a narrow slit in the soils, a roller with many spikes making indentations in the soil, or prongs with function like a mini-subsoiler.
Heavy traffic areas on site (especially in a zone 5-25’ around buildings but not within a 5’ perimeter around foundation walls)	Apply full soil restoration (de-compaction and compost enhancement)	Deep rip the affected thickness of the exposed subsoil material, aggressively fracturing it before the protected topsoil is reapplied on site. De-compact simultaneously through the restored topsoil layer and the upper half of the affected subsoil.
Areas where runoff reduction and/or infiltration practices are applied	Restoration not required, but may be applied to enhance the reduction specified for appropriate practices.	Protect from any ongoing construction activity

During periods of relatively low to moderate subsoil moisture, the disturbed soils are returned to rough grade and the following soil restoration steps are applied:

1. Apply 3-inches of compost over subsoil.
2. Till compost into subsoil to a depth of at least 12” using a cat-mounted ripper, tractor-mounted disc, or tiller, mixing and circulating air and compost into subsoils.
3. Rock-pick until uplifted stone/rock materials of 4-inches and larger size are cleaned off the site.
4. Apply topsoil to a depth of 6-inches.
5. Vegetate as required by the project plans.

## 5 Stormwater Management Plan

The goals of this Stormwater Management Plan are to:

1. Analyze the peak rate of runoff under pre- and post-development conditions.
2. Maintain the pre-development rate of runoff in order to minimize impacts to adjacent or downstream properties.



3. Minimize the impact of the quality of runoff exiting the site.

These objectives will be met by applying Green Infrastructure Practices and Best Management Practices (BMPs). Stormwater runoff from the proposed project will be collected and conveyed to the proposed stormwater management facilities. Stormwater runoff will be detained, treated, and released at a rate equal to or less than that which existed prior to development of the project site.

## 5.1 Redevelopment

Per NYSDEC guidelines, the proposed stormwater will be designed using the redevelopment standards (Chapter 9). Credit for the redeveloped existing impervious will be taken in the Water Quality (WQv) Calculations.

## 5.2 Hydrologic Analysis

The study area was made up of one subcatchment for pre-development conditions and post-development conditions. This was dictated by watershed conditions, methods of collection, conveyance, and points of discharge. Watershed delineations were defined using the surveyed site topography.

HydroCAD, a Computer-Aided-Design (CAD) program, was used to analyze the hydrologic characteristics of the pre-development watershed conditions, post-development watershed conditions, and proposed stormwater management systems. HydroCAD has the capability of computing hydrographs (which represents discharge rates characteristic of specified watershed conditions, precipitation, and geologic factors), combining hydrographs, and routing flows through pipes, streams, channels, and ponds.

### 5.2.1 Rainfall Data

Rainfall data utilized in the modeling and analysis was obtained from National Weather Service (NWS) Technical Paper 40 (TP-40), Rainfall Frequency Atlas of the U.S. Weather Bureau, published by the U.S. Department of Commerce. A Type III rainfall distribution was used to evaluate the pre- and post-development stormwater runoff conditions for the 1-, 10-, and 100-year 24-hour storm events for Dutchess County. Rainfall data specific to the portion of Dutchess County under consideration is provided in [Table 3](#) below.

**Table 3: Rainfall Data**

Storm Event	24-Hour Rainfall
1-year	2.59 inches
10-year	4.66 inches
100-year	8.26 inches



## 5.2.2 Unified Stormwater Sizing Criteria

### 5.2.2.1 *Water Quantity Control*

## 5.2.3 Comparison of Peak Discharge Rates

A comparison of the pre- and post-development peak discharge rates is provided in [Table 9](#) below.

**Table 6: Comparison of Pre- & Post-Development Peak Discharge Rates**

Storm Event	Pre (cfs)	Post (cfs)	Difference
1-year	2.18	0.5	-73%
10-year	5.16	2.69	-48%
100-year	10.41	7.42	-28%

Infiltration systems will mitigate peak flows. The on-site soils are very suitable for infiltration.

Comparison of the peak discharge rates for pre- and post-development watershed conditions demonstrates that the peak rate of runoff from the proposed development will remain the nearly the same or not be increased. Therefore, the proposed development will not adversely impact the downstream or adjacent properties, receiving water bodies or courses, or wetlands. The results of the computer modeling used to analyze the pre- and post-development watershed conditions are presented in [Appendix A](#).

### 5.2.3.1 *Water Quality Treatment*

The Water Quality Objective will be met by designing the infiltration and pretreatment based in the Redevelopment Criteria set forth by the NYSDEC.

## 6 Post Construction Requirements

### 6.1 Inspection and Maintenance

Post-construction inspections and maintenance shall be performed by the homeowners. Inspections and maintenance for the various site components and stormwater management facilities shall be performed in accordance with the accompanying project plans and this SWPPP.

A summary of the general site inspection and maintenance parameters is provided in the table below



**Table 7: General Site Post-Construction Inspection and Maintenance**

Maintenance Item	Frequency	Description of Inspection Parameters	Description of Remedy Procedures
Site Structures	Annual & After Major Storms	<ul style="list-style-type: none"> <li>-Accumulated sediment in catch basin sumps</li> <li>-Accumulated debris and litter</li> <li>-Damage or fatigue of storm structures or associated components</li> <li>-Accumulation of pollutants, including oils or grease, in catch basin sumps</li> </ul>	<ul style="list-style-type: none"> <li>-Remove</li> <li>-Remove</li> <li>-Replace and/or repair, as necessary</li> <li>-Remove pollutants from catch basins. Replace and/or repair pollutant source.</li> <li>-Remove (sweep min. 2 times/year)</li> <li>-Remove</li> </ul>
Pavement	Biannual/Annual	<ul style="list-style-type: none"> <li>-Accumulated sediment in paved areas</li> <li>-Accumulated debris and litter</li> </ul>	<ul style="list-style-type: none"> <li>-Remove (sweep min. 2 times/year)</li> <li>-Remove</li> </ul>
Embankments	Annual	<ul style="list-style-type: none"> <li>-Differential settlement of embankments</li> <li>-Embankment erosion</li> <li>-Animal burrows</li> <li>-Cracking, bulging, or sliding of embankment</li> </ul>	<ul style="list-style-type: none"> <li>-Stabilize and restore to original specs</li> <li>-Stabilize and restore to original specs</li> <li>-Remove</li> <li>-Stabilize and restore to original specs</li> </ul>
Grass and Landscaped areas	Annual	<ul style="list-style-type: none"> <li>-Vegetation: 80% coverage + less than 15% invasive plant species</li> <li>-Unauthorized plantings</li> <li>-Undesirable vegetative growth</li> <li>-Accumulated debris and litter</li> </ul>	<ul style="list-style-type: none"> <li>-Restore original specs</li> <li>-Remove</li> <li>-Mow a min. of 3 times/year. May increase for aesthetic reasons.</li> <li>-Remove</li> </ul>
Winter Maintenance	Monthly	<ul style="list-style-type: none"> <li>-Accumulation of snow and ice on catch basins, inlet and outlet structures, and end sections</li> <li>-Stock piled snow near inlets and outlets</li> <li>-Remaining deicing materials</li> </ul>	<ul style="list-style-type: none"> <li>-Remove</li> <li>-Remove</li> <li>-Remove in early spring by sweeping</li> </ul>
Swales	Monthly	<ul style="list-style-type: none"> <li>-Erosion of side slopes</li> <li>-Formation of rills or gullies</li> <li>-Excess grass growth</li> <li>-Undesirable vegetative growth</li> <li>-Accumulated debris, litter, or sediment</li> <li>-Residual deicing materials (sand)</li> </ul>	<ul style="list-style-type: none"> <li>-Stabilize and restore to original specs</li> <li>-Repair and restore to original specs</li> <li>-Mow</li> <li>-Remove</li> <li>-Remove</li> <li>-Remove &amp; replace any damaged vegetation</li> </ul>



## 7 Conclusion

This Stormwater Pollution Prevention Plan for the for Dutchess Shepard incorporates an Erosion and Sediment Control Plan and Stormwater Management Plan. The SWPPP identifies the measures to be implemented during construction to minimize soil erosion and control sediment transport off-site, and after construction to control the water quality and quantity of stormwater runoff from the developed site to minimize adverse effects to downstream conditions.

This Stormwater Pollution Prevention Plan has been developed in accordance with the requirements of the Town of Beekman and the New York State Department of Environmental Conservation (NYSDEC) State Pollutant Discharge Elimination System (SPDES) Phase II technical standards. It is our opinion that the proposed project will not adversely impact adjacent or downstream properties, or receiving surface waters or wetlands, if the erosion and sediment control measures and stormwater management facilities are properly constructed, and maintained in accordance with the requirements outlined herein.





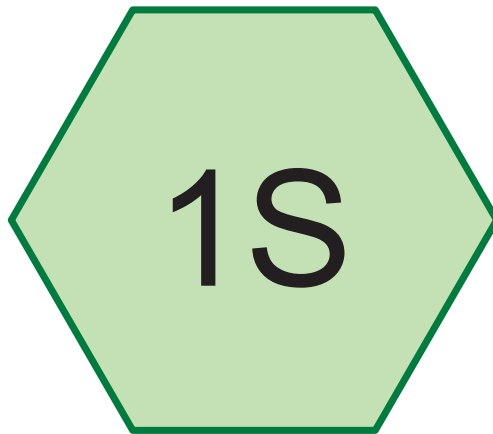
## **Appendix A**

---

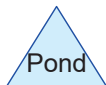
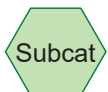
### HydroCAD Analysis







Existing



## Mulberry Subdivision

Prepared by Hildenbrand Engineering, PLLC

HydroCAD® 10.10-6a s/n 11988 © 2020 HydroCAD Software Solutions LLC

Printed 5/1/2023

Page 2

### Rainfall Events Listing

Event#	Event Name	Storm Type	Curve	Mode	Duration (hours)	B/B	Depth (inches)	AMC
1	1-Year	Type III 24-hr		Default	24.00	1	2.59	2
2	10-Year	Type III 24-hr		Default	24.00	1	4.66	2
3	100-Year	Type III 24-hr		Default	24.00	1	8.26	2

# Mulberry Subdivision

Prepared by Hildenbrand Engineering, PLLC

HydroCAD® 10.10-6a s/n 11988 © 2020 HydroCAD Software Solutions LLC

Type III 24-hr 1-Year Rainfall=2.59"

Printed 5/1/2023

Page 3

## Summary for Subcatchment 1S: Existing

Runoff = 2.18 cfs @ 12.09 hrs, Volume= 0.158 af, Depth= 1.32"

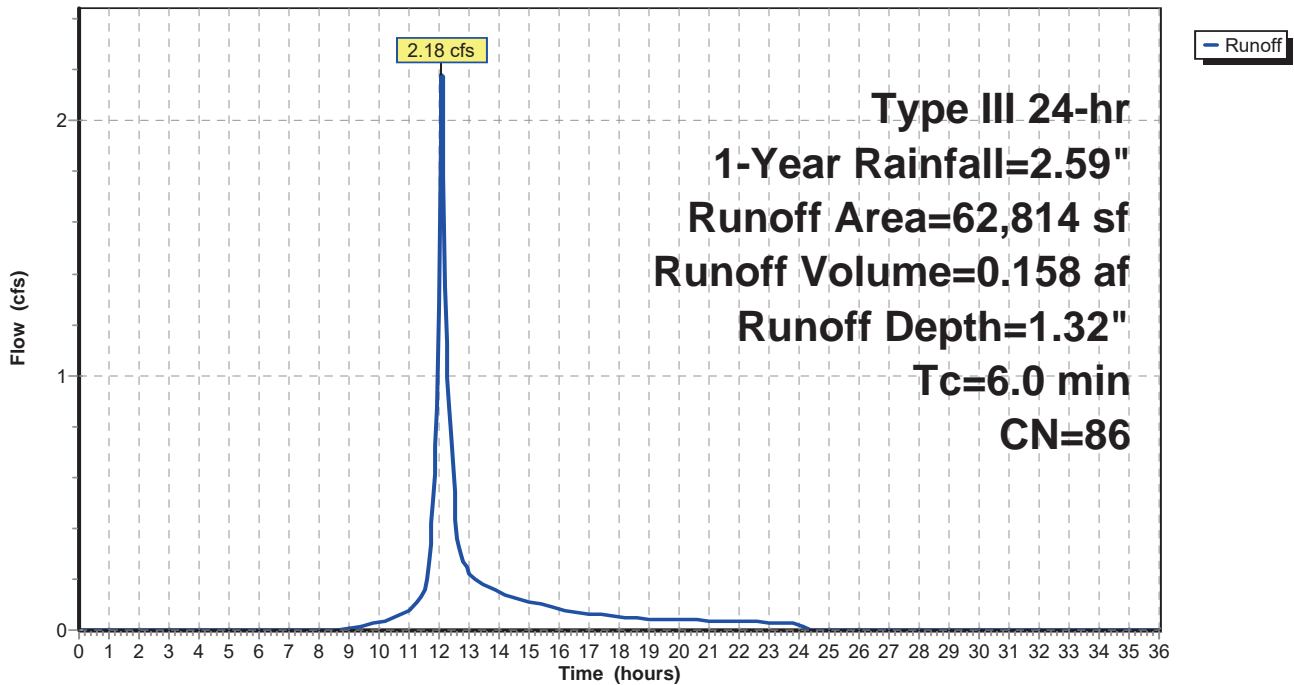
Runoff by SCS TR-20 method, UH=SCS, Weighted-CN, Time Span= 0.00-36.00 hrs, dt= 0.05 hrs  
Type III 24-hr 1-Year Rainfall=2.59"

	Area (sf)	CN	Description
*	11,705	98	Building
*	10,920	98	Parking
	40,189	79	<50% Grass cover, Poor, HSG B
	62,814	86	Weighted Average
	40,189		63.98% Pervious Area
	22,625		36.02% Impervious Area

Tc (min)	Length (feet)	Slope (ft/ft)	Velocity (ft/sec)	Capacity (cfs)	Description
6.0					Direct Entry,

## Subcatchment 1S: Existing

Hydrograph



# Mulberry Subdivision

Prepared by Hildenbrand Engineering, PLLC

HydroCAD® 10.10-6a s/n 11988 © 2020 HydroCAD Software Solutions LLC

Type III 24-hr 10-Year Rainfall=4.66"

Printed 5/1/2023

Page 4

## Summary for Subcatchment 1S: Existing

Runoff = 5.16 cfs @ 12.09 hrs, Volume= 0.379 af, Depth= 3.15"

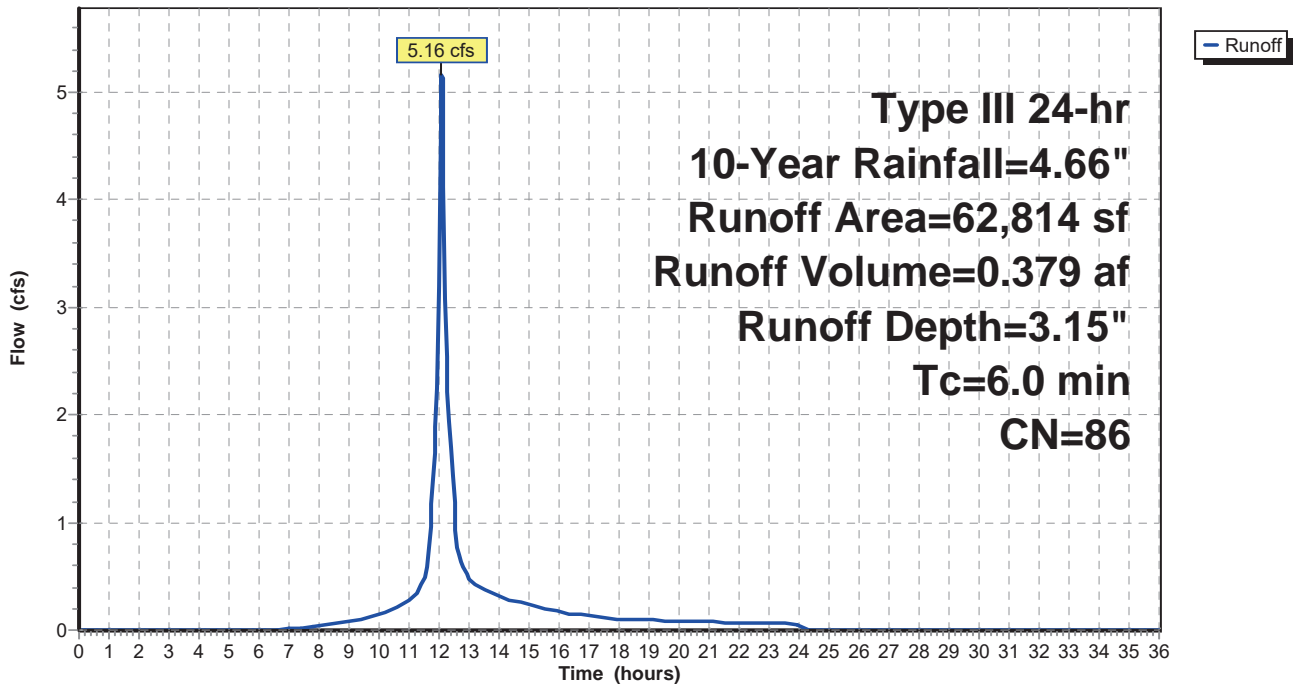
Runoff by SCS TR-20 method, UH=SCS, Weighted-CN, Time Span= 0.00-36.00 hrs, dt= 0.05 hrs  
Type III 24-hr 10-Year Rainfall=4.66"

	Area (sf)	CN	Description
*	11,705	98	Building
*	10,920	98	Parking
	40,189	79	<50% Grass cover, Poor, HSG B
	62,814	86	Weighted Average
	40,189		63.98% Pervious Area
	22,625		36.02% Impervious Area

Tc (min)	Length (feet)	Slope (ft/ft)	Velocity (ft/sec)	Capacity (cfs)	Description
6.0					Direct Entry,

## Subcatchment 1S: Existing

Hydrograph



# Mulberry Subdivision

Prepared by Hildenbrand Engineering, PLLC

HydroCAD® 10.10-6a s/n 11988 © 2020 HydroCAD Software Solutions LLC

Type III 24-hr 100-Year Rainfall=8.26"

Printed 5/1/2023

Page 5

## Summary for Subcatchment 1S: Existing

Runoff = 10.41 cfs @ 12.09 hrs, Volume= 0.791 af, Depth= 6.58"

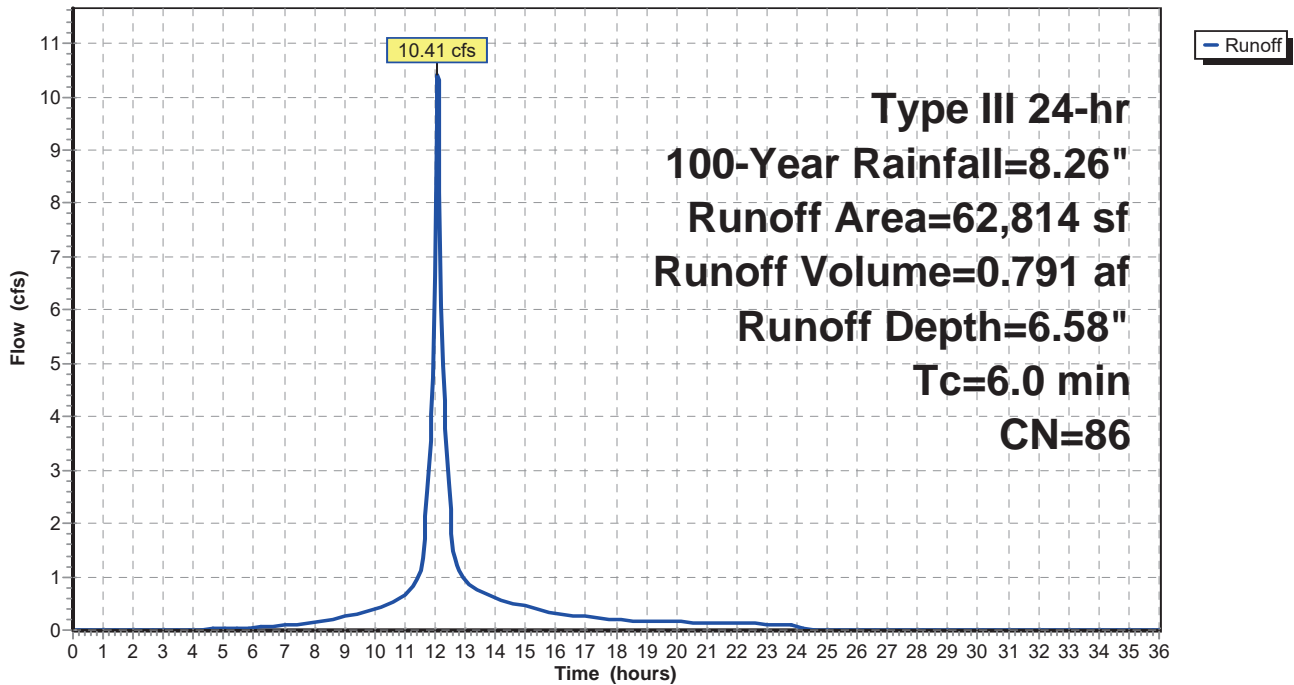
Runoff by SCS TR-20 method, UH=SCS, Weighted-CN, Time Span= 0.00-36.00 hrs, dt= 0.05 hrs  
Type III 24-hr 100-Year Rainfall=8.26"

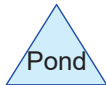
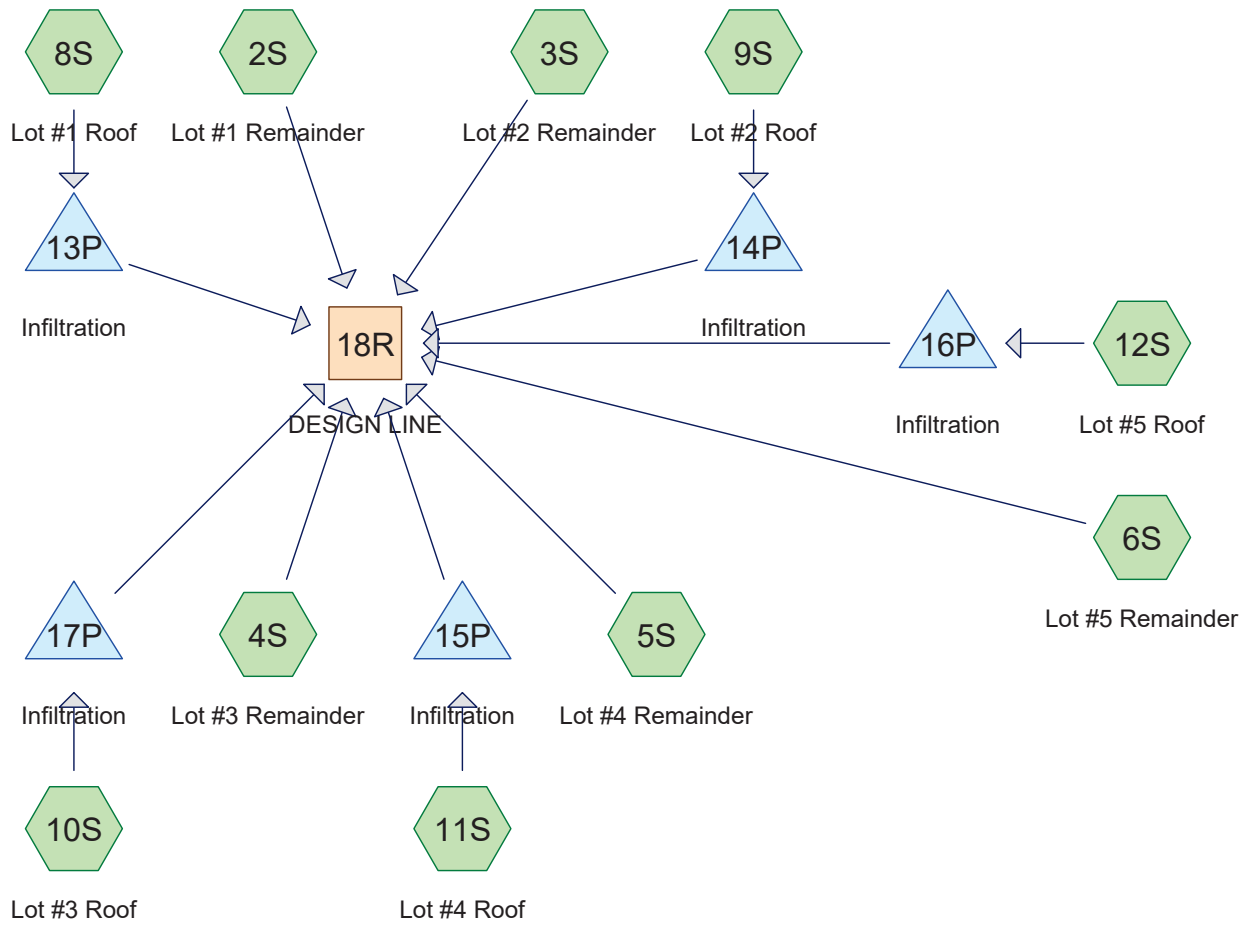
	Area (sf)	CN	Description
*	11,705	98	Building
*	10,920	98	Parking
	40,189	79	<50% Grass cover, Poor, HSG B
	62,814	86	Weighted Average
	40,189		63.98% Pervious Area
	22,625		36.02% Impervious Area

Tc (min)	Length (feet)	Slope (ft/ft)	Velocity (ft/sec)	Capacity (cfs)	Description
6.0					Direct Entry,

## Subcatchment 1S: Existing

Hydrograph





**Routing Diagram for Mulberry Subdivision**  
 Prepared by Hildenbrand Engineering, PLLC, Printed 5/1/2023  
 HydroCAD® 10.10-6a s/n 11988 © 2020 HydroCAD Software Solutions LLC

## Mulberry Subdivision

Prepared by Hildenbrand Engineering, PLLC

HydroCAD® 10.10-6a s/n 11988 © 2020 HydroCAD Software Solutions LLC

Printed 5/1/2023

Page 2

### Rainfall Events Listing

Event#	Event Name	Storm Type	Curve	Mode	Duration (hours)	B/B	Depth (inches)	AMC
1	1-Year	Type III 24-hr		Default	24.00	1	2.59	2
2	10-Year	Type III 24-hr		Default	24.00	1	4.66	2
3	100-Year	Type III 24-hr		Default	24.00	1	8.26	2

# Mulberry Subdivision

Prepared by Hildenbrand Engineering, PLLC

HydroCAD® 10.10-6a s/n 11988 © 2020 HydroCAD Software Solutions LLC

Type III 24-hr 1-Year Rainfall=2.59"

Printed 5/1/2023

Page 3

## Summary for Subcatchment 2S: Lot #1 Remainder

Runoff = 0.04 cfs @ 12.11 hrs, Volume= 0.004 af, Depth= 0.36"  
 Routed to Reach 18R : DESIGN LINE

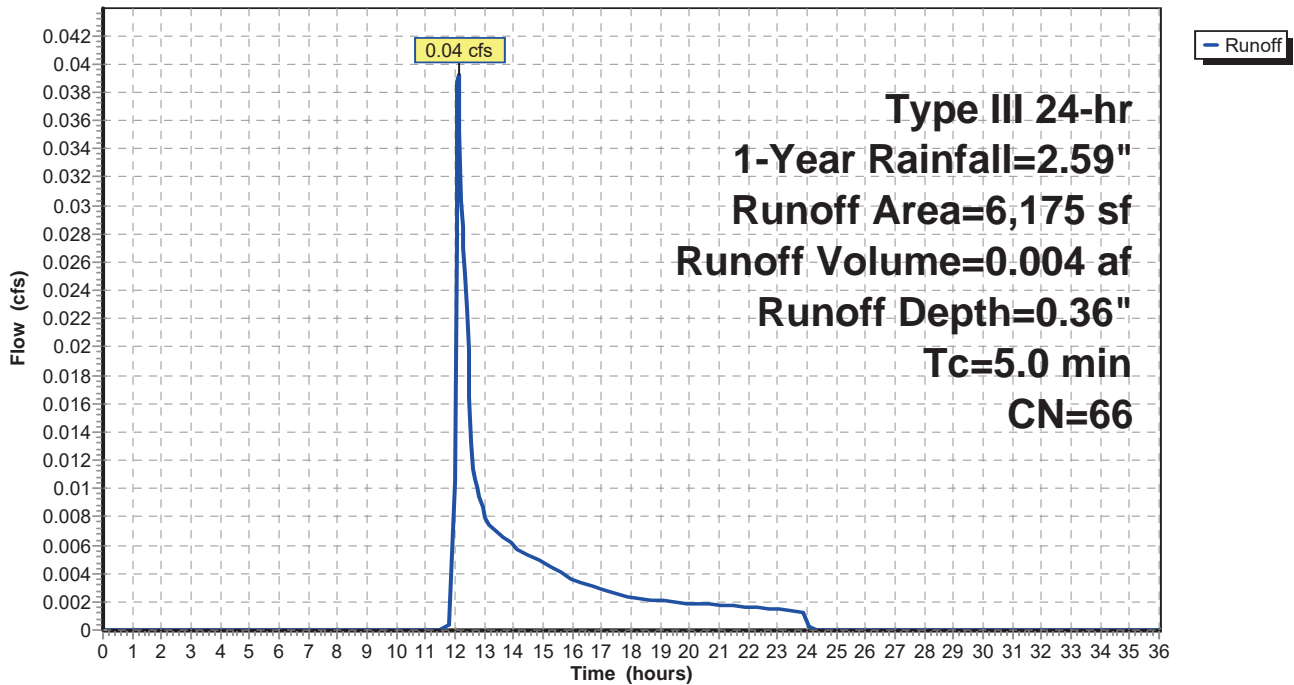
Runoff by SCS TR-20 method, UH=SCS, Weighted-CN, Time Span= 0.00-36.00 hrs, dt= 0.05 hrs  
 Type III 24-hr 1-Year Rainfall=2.59"

	Area (sf)	CN	Description
*	815	98	Driveway
	5,360	61	>75% Grass cover, Good, HSG B
	6,175	66	Weighted Average
	5,360		86.80% Pervious Area
	815		13.20% Impervious Area

Tc (min)	Length (feet)	Slope (ft/ft)	Velocity (ft/sec)	Capacity (cfs)	Description
5.0					Direct Entry,

## Subcatchment 2S: Lot #1 Remainder

Hydrograph





# Mulberry Subdivision

Prepared by Hildenbrand Engineering, PLLC

HydroCAD® 10.10-6a s/n 11988 © 2020 HydroCAD Software Solutions LLC

Type III 24-hr 1-Year Rainfall=2.59"

Printed 5/1/2023

Page 4

## Summary for Subcatchment 3S: Lot #2 Remainder

Runoff = 0.04 cfs @ 12.11 hrs, Volume= 0.004 af, Depth= 0.36"  
 Routed to Reach 18R : DESIGN LINE

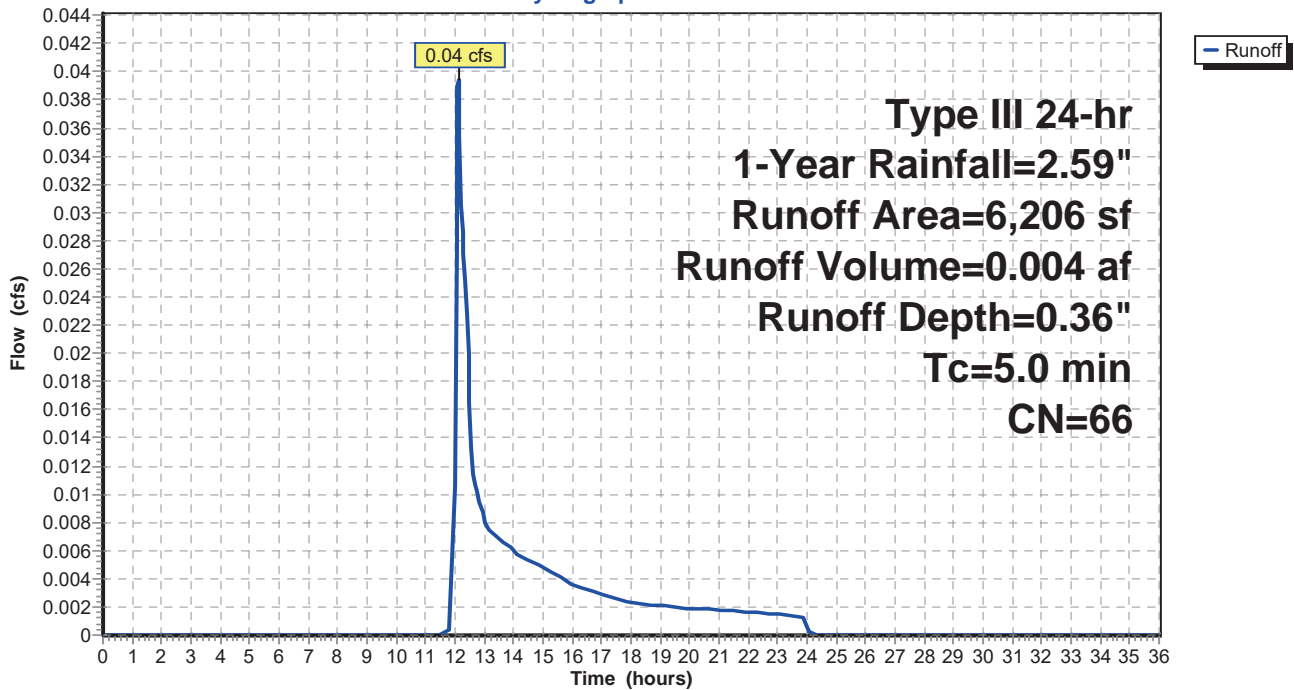
Runoff by SCS TR-20 method, UH=SCS, Weighted-CN, Time Span= 0.00-36.00 hrs, dt= 0.05 hrs  
 Type III 24-hr 1-Year Rainfall=2.59"

	Area (sf)	CN	Description
*	815	98	Driveway
	5,391	61	>75% Grass cover, Good, HSG B
	6,206	66	Weighted Average
	5,391		86.87% Pervious Area
	815		13.13% Impervious Area

Tc (min)	Length (feet)	Slope (ft/ft)	Velocity (ft/sec)	Capacity (cfs)	Description
5.0					Direct Entry,

## Subcatchment 3S: Lot #2 Remainder

Hydrograph



# Mulberry Subdivision

Prepared by Hildenbrand Engineering, PLLC

HydroCAD® 10.10-6a s/n 11988 © 2020 HydroCAD Software Solutions LLC

Type III 24-hr 1-Year Rainfall=2.59"

Printed 5/1/2023

Page 5

## Summary for Subcatchment 4S: Lot #3 Remainder

Runoff = 0.34 cfs @ 12.09 hrs, Volume= 0.027 af, Depth= 0.66"  
 Routed to Reach 18R : DESIGN LINE

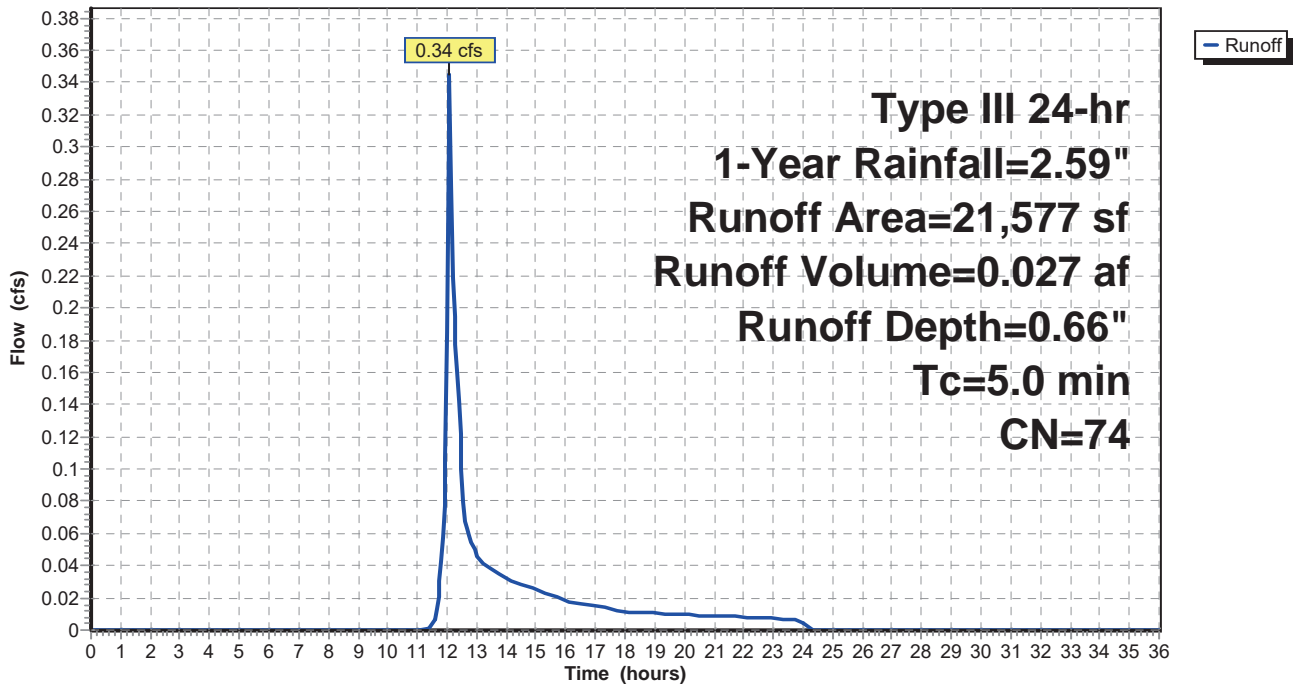
Runoff by SCS TR-20 method, UH=SCS, Weighted-CN, Time Span= 0.00-36.00 hrs, dt= 0.05 hrs  
 Type III 24-hr 1-Year Rainfall=2.59"

	Area (sf)	CN	Description
*	7,583	98	Driveway
	13,994	61	>75% Grass cover, Good, HSG B
	21,577	74	Weighted Average
	13,994		64.86% Pervious Area
	7,583		35.14% Impervious Area

Tc (min)	Length (feet)	Slope (ft/ft)	Velocity (ft/sec)	Capacity (cfs)	Description
5.0					Direct Entry,

## Subcatchment 4S: Lot #3 Remainder

Hydrograph



**Mulberry Subdivision**

Prepared by Hildenbrand Engineering, PLLC

HydroCAD® 10.10-6a s/n 11988 © 2020 HydroCAD Software Solutions LLC

Type III 24-hr 1-Year Rainfall=2.59"

Printed 5/1/2023

Page 6

**Summary for Subcatchment 5S: Lot #4 Remainder**

Runoff = 0.04 cfs @ 12.12 hrs, Volume= 0.004 af, Depth= 0.33"  
 Routed to Reach 18R : DESIGN LINE

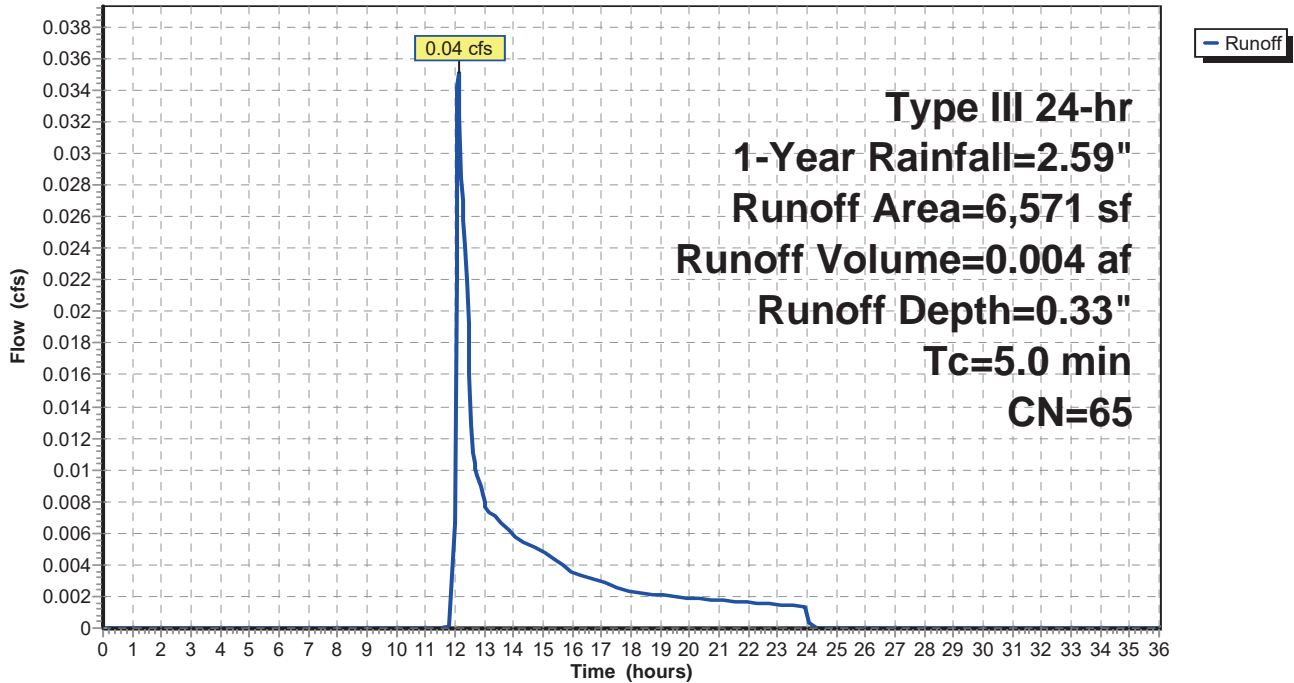
Runoff by SCS TR-20 method, UH=SCS, Weighted-CN, Time Span= 0.00-36.00 hrs, dt= 0.05 hrs  
 Type III 24-hr 1-Year Rainfall=2.59"

	Area (sf)	CN	Description
*	709	98	Driveway
	5,862	61	>75% Grass cover, Good, HSG B
	6,571	65	Weighted Average
	5,862		89.21% Pervious Area
	709		10.79% Impervious Area

Tc (min)	Length (feet)	Slope (ft/ft)	Velocity (ft/sec)	Capacity (cfs)	Description
5.0					Direct Entry,

**Subcatchment 5S: Lot #4 Remainder**

Hydrograph



# Mulberry Subdivision

Prepared by Hildenbrand Engineering, PLLC

HydroCAD® 10.10-6a s/n 11988 © 2020 HydroCAD Software Solutions LLC

Type III 24-hr 1-Year Rainfall=2.59"

Printed 5/1/2023

Page 7

## Summary for Subcatchment 6S: Lot #5 Remainder

Runoff = 0.04 cfs @ 12.11 hrs, Volume= 0.005 af, Depth= 0.36"  
 Routed to Reach 18R : DESIGN LINE

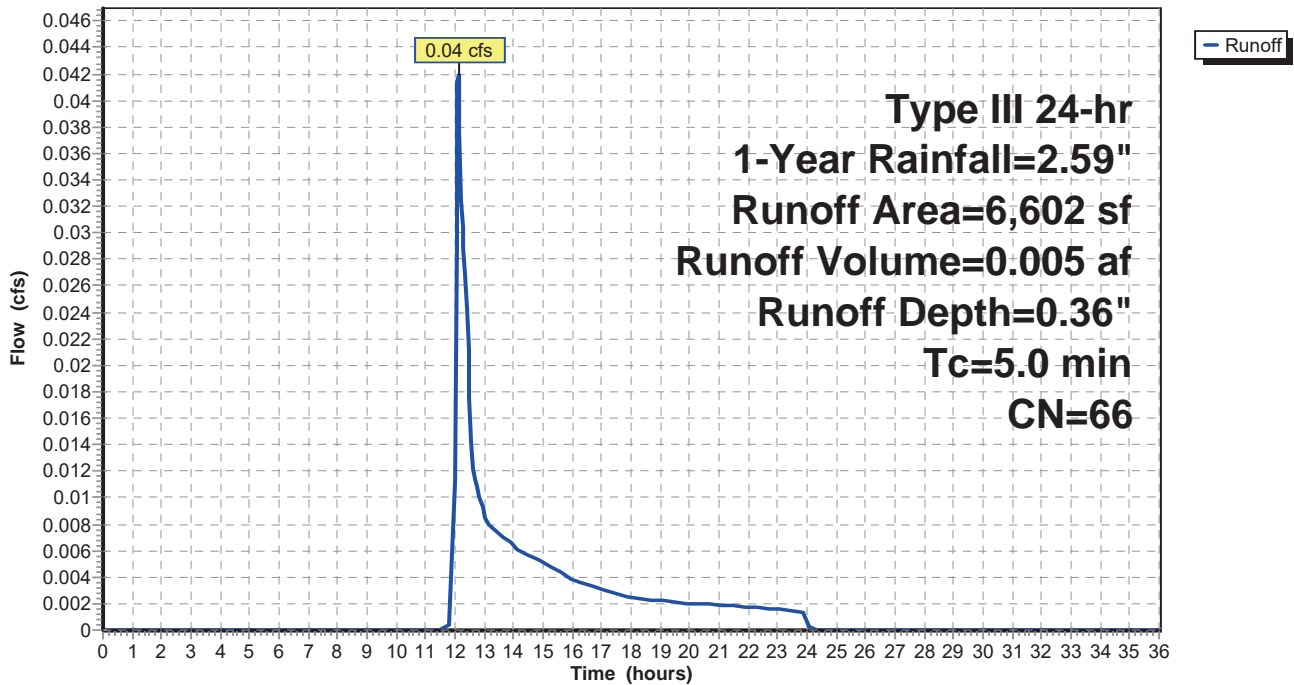
Runoff by SCS TR-20 method, UH=SCS, Weighted-CN, Time Span= 0.00-36.00 hrs, dt= 0.05 hrs  
 Type III 24-hr 1-Year Rainfall=2.59"

	Area (sf)	CN	Description
*	974	98	Driveway
	5,628	61	>75% Grass cover, Good, HSG B
	6,602	66	Weighted Average
	5,628		85.25% Pervious Area
	974		14.75% Impervious Area

Tc (min)	Length (feet)	Slope (ft/ft)	Velocity (ft/sec)	Capacity (cfs)	Description
5.0					Direct Entry,

## Subcatchment 6S: Lot #5 Remainder

Hydrograph



**Mulberry Subdivision**

Prepared by Hildenbrand Engineering, PLLC

HydroCAD® 10.10-6a s/n 11988 © 2020 HydroCAD Software Solutions LLC

Type III 24-hr 1-Year Rainfall=2.59"

Printed 5/1/2023

Page 8

**Summary for Subcatchment 8S: Lot #1 Roof**

Runoff = 0.11 cfs @ 12.07 hrs, Volume= 0.009 af, Depth= 2.36"  
 Routed to Pond 13P : Infiltration

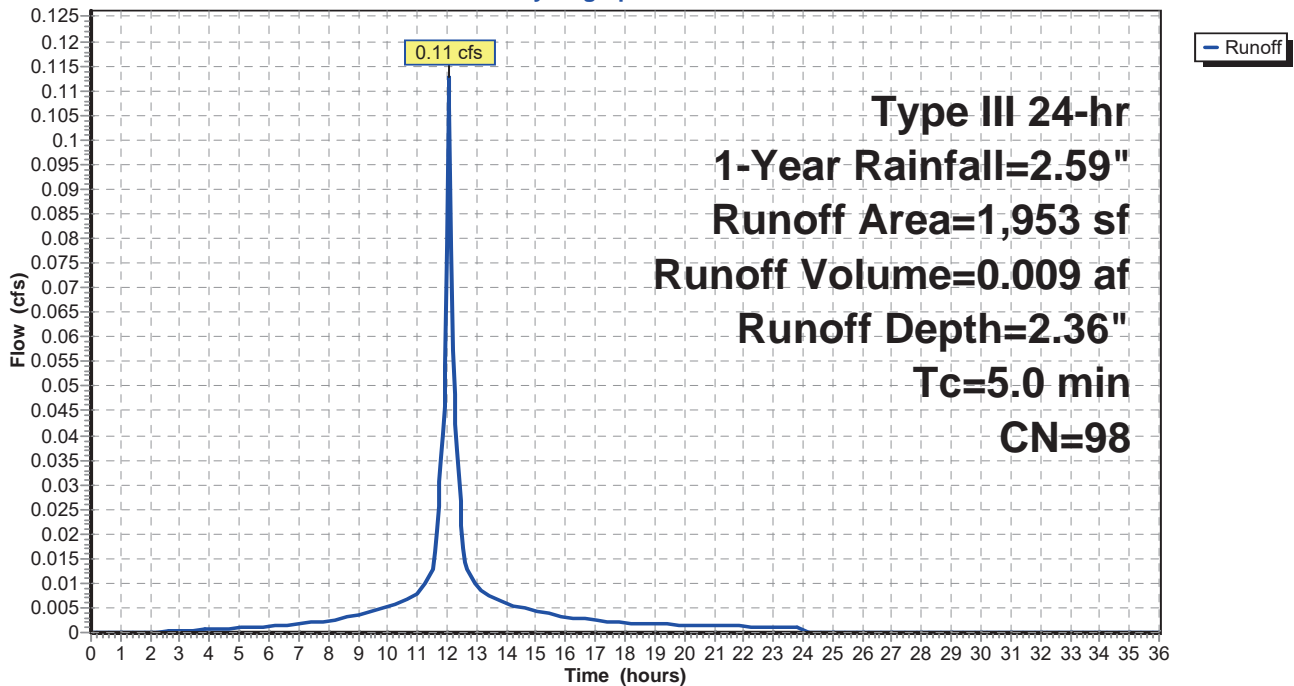
Runoff by SCS TR-20 method, UH=SCS, Weighted-CN, Time Span= 0.00-36.00 hrs, dt= 0.05 hrs  
 Type III 24-hr 1-Year Rainfall=2.59"

Area (sf)	CN	Description
* 1,953	98	Roof Area
1,953		100.00% Impervious Area

Tc (min)	Length (feet)	Slope (ft/ft)	Velocity (ft/sec)	Capacity (cfs)	Description
5.0					Direct Entry,

**Subcatchment 8S: Lot #1 Roof**

Hydrograph



**Mulberry Subdivision**

Prepared by Hildenbrand Engineering, PLLC

HydroCAD® 10.10-6a s/n 11988 © 2020 HydroCAD Software Solutions LLC

Type III 24-hr 1-Year Rainfall=2.59"

Printed 5/1/2023

Page 9

**Summary for Subcatchment 9S: Lot #2 Roof**

Runoff = 0.11 cfs @ 12.07 hrs, Volume= 0.009 af, Depth= 2.36"  
 Routed to Pond 14P : Infiltration

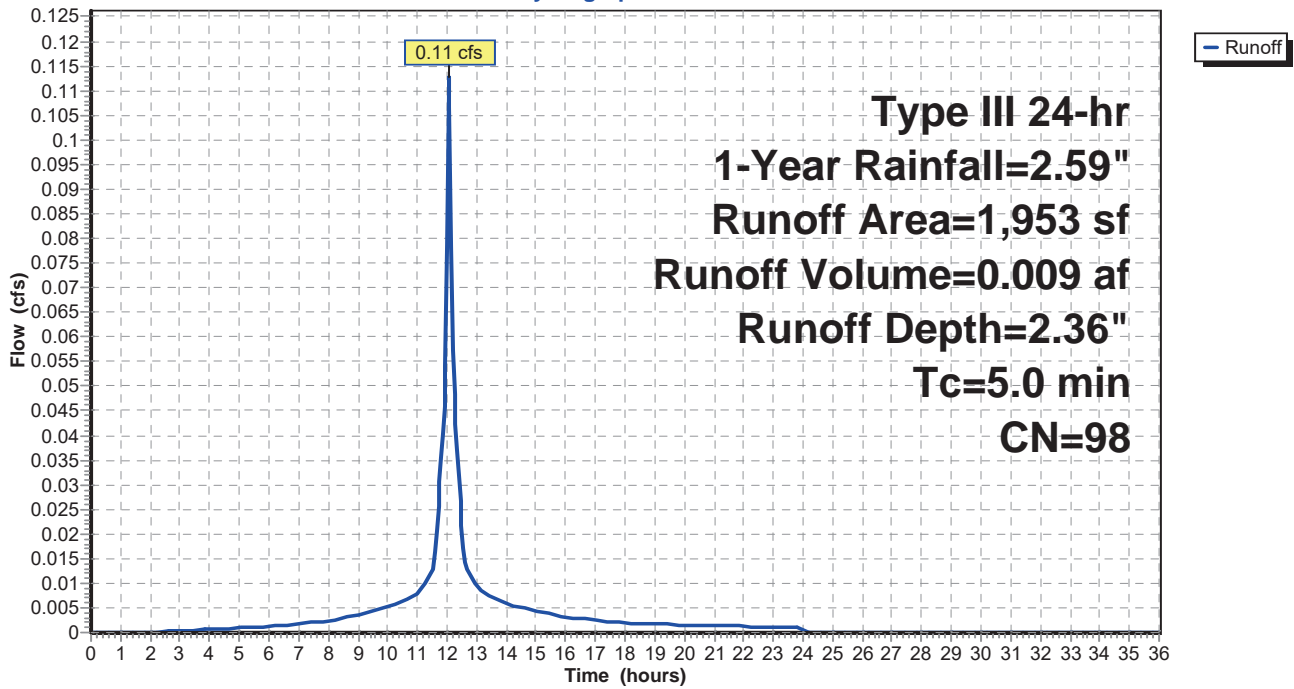
Runoff by SCS TR-20 method, UH=SCS, Weighted-CN, Time Span= 0.00-36.00 hrs, dt= 0.05 hrs  
 Type III 24-hr 1-Year Rainfall=2.59"

Area (sf)	CN	Description
* 1,953	98	Roof Area
1,953		100.00% Impervious Area

Tc (min)	Length (feet)	Slope (ft/ft)	Velocity (ft/sec)	Capacity (cfs)	Description
5.0					Direct Entry,

**Subcatchment 9S: Lot #2 Roof**

Hydrograph



**Mulberry Subdivision**

Prepared by Hildenbrand Engineering, PLLC

HydroCAD® 10.10-6a s/n 11988 © 2020 HydroCAD Software Solutions LLC

Type III 24-hr 1-Year Rainfall=2.59"

Printed 5/1/2023

Page 10

**Summary for Subcatchment 10S: Lot #3 Roof**

Runoff = 0.46 cfs @ 12.07 hrs, Volume= 0.036 af, Depth= 2.36"  
 Routed to Pond 17P : Infiltration

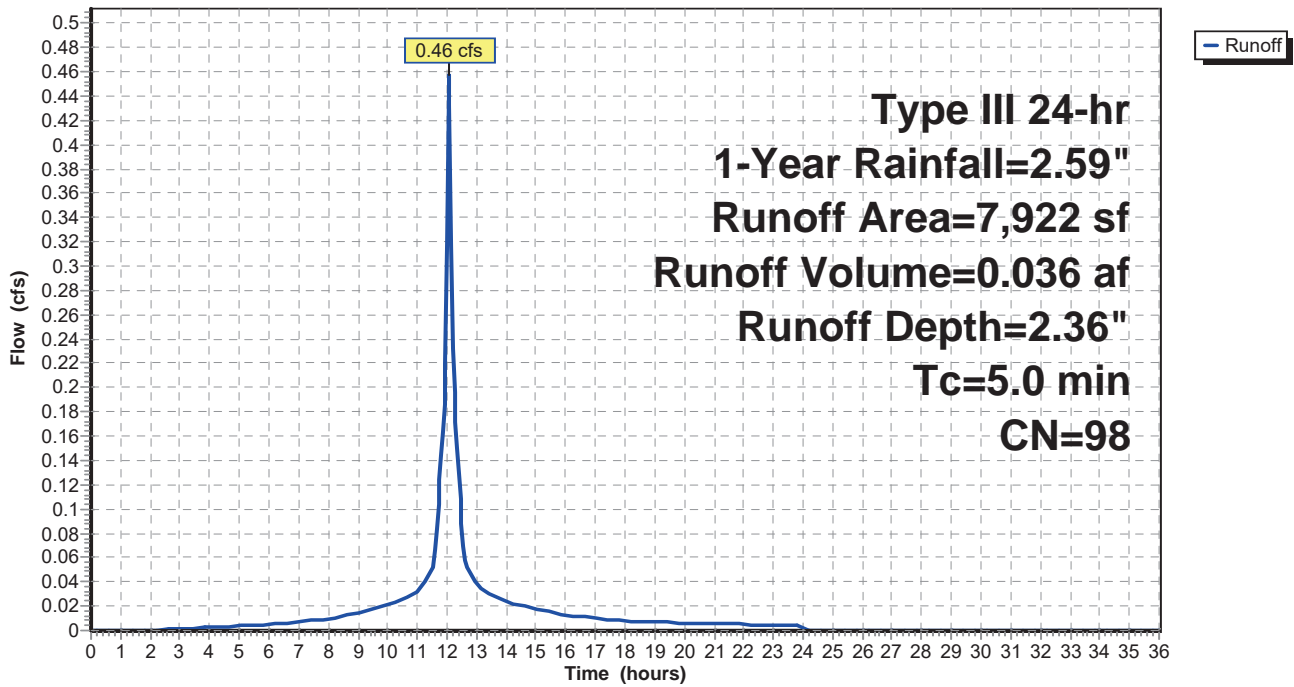
Runoff by SCS TR-20 method, UH=SCS, Weighted-CN, Time Span= 0.00-36.00 hrs, dt= 0.05 hrs  
 Type III 24-hr 1-Year Rainfall=2.59"

Area (sf)	CN	Description
* 7,922	98	Roof Area
7,922		100.00% Impervious Area

Tc (min)	Length (feet)	Slope (ft/ft)	Velocity (ft/sec)	Capacity (cfs)	Description
5.0					Direct Entry,

**Subcatchment 10S: Lot #3 Roof**

Hydrograph



**Mulberry Subdivision**

Prepared by Hildenbrand Engineering, PLLC

HydroCAD® 10.10-6a s/n 11988 © 2020 HydroCAD Software Solutions LLC

Type III 24-hr 1-Year Rainfall=2.59"

Printed 5/1/2023

Page 11

**Summary for Subcatchment 11S: Lot #4 Roof**

Runoff = 0.11 cfs @ 12.07 hrs, Volume= 0.009 af, Depth= 2.36"  
 Routed to Pond 15P : Infiltration

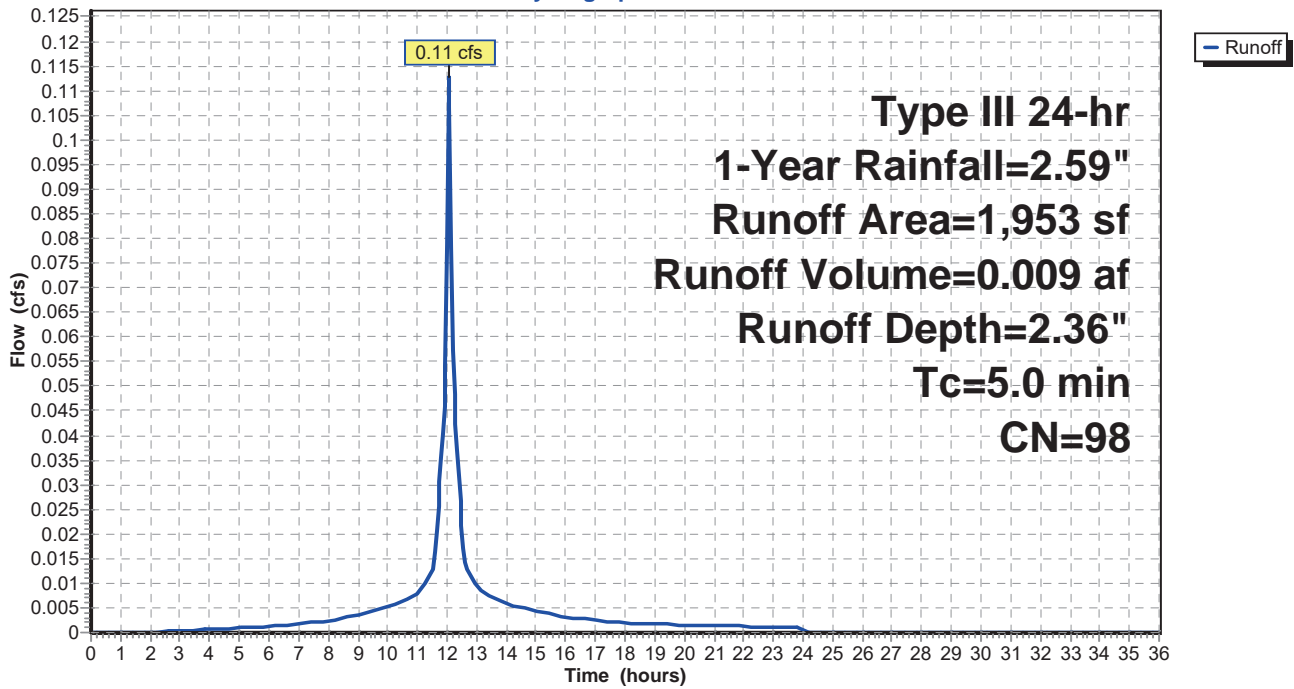
Runoff by SCS TR-20 method, UH=SCS, Weighted-CN, Time Span= 0.00-36.00 hrs, dt= 0.05 hrs  
 Type III 24-hr 1-Year Rainfall=2.59"

Area (sf)	CN	Description
* 1,953	98	Roof Area
1,953		100.00% Impervious Area

Tc (min)	Length (feet)	Slope (ft/ft)	Velocity (ft/sec)	Capacity (cfs)	Description
5.0					Direct Entry,

**Subcatchment 11S: Lot #4 Roof**

Hydrograph





**Mulberry Subdivision**

Prepared by Hildenbrand Engineering, PLLC

HydroCAD® 10.10-6a s/n 11988 © 2020 HydroCAD Software Solutions LLC

Type III 24-hr 1-Year Rainfall=2.59"

Printed 5/1/2023

Page 12

**Summary for Subcatchment 12S: Lot #5 Roof**

Runoff = 0.11 cfs @ 12.07 hrs, Volume= 0.009 af, Depth= 2.36"  
 Routed to Pond 16P : Infiltration

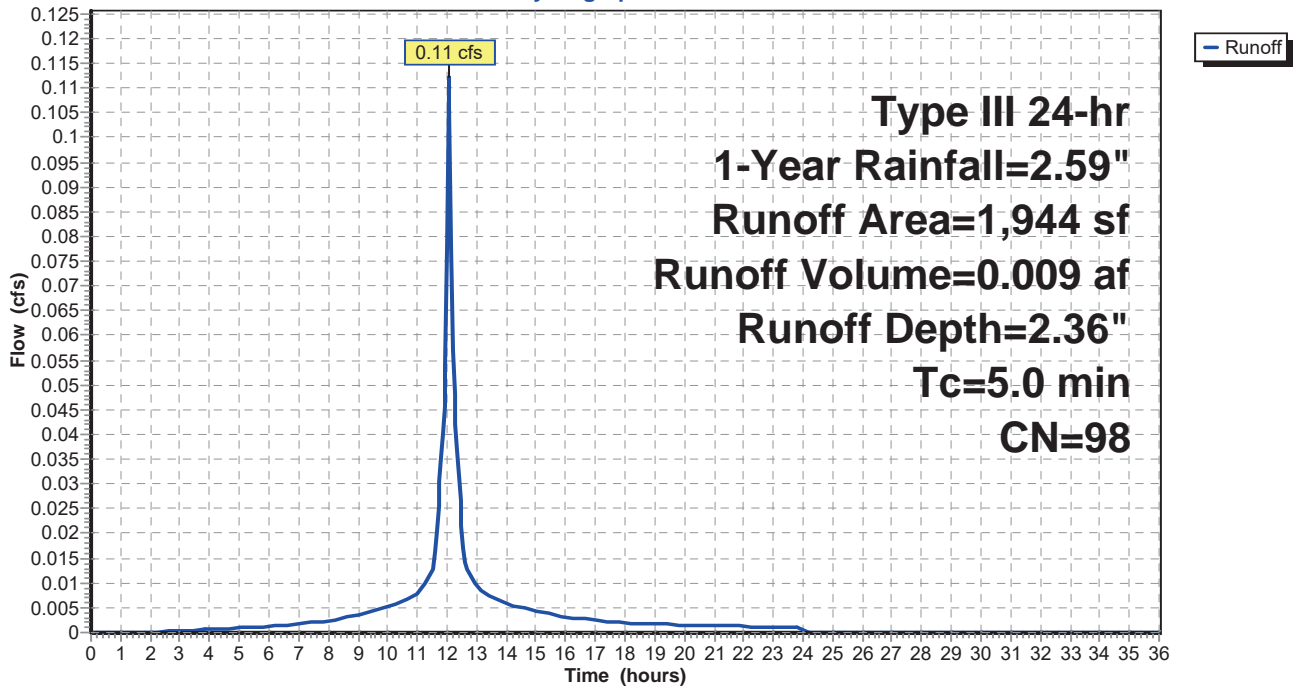
Runoff by SCS TR-20 method, UH=SCS, Weighted-CN, Time Span= 0.00-36.00 hrs, dt= 0.05 hrs  
 Type III 24-hr 1-Year Rainfall=2.59"

Area (sf)	CN	Description
* 1,944	98	Roof Area
1,944		100.00% Impervious Area

Tc (min)	Length (feet)	Slope (ft/ft)	Velocity (ft/sec)	Capacity (cfs)	Description
5.0					Direct Entry,

**Subcatchment 12S: Lot #5 Roof**

Hydrograph



# Mulberry Subdivision

Prepared by Hildenbrand Engineering, PLLC

HydroCAD® 10.10-6a s/n 11988 © 2020 HydroCAD Software Solutions LLC

Type III 24-hr 1-Year Rainfall=2.59"

Printed 5/1/2023

Page 13

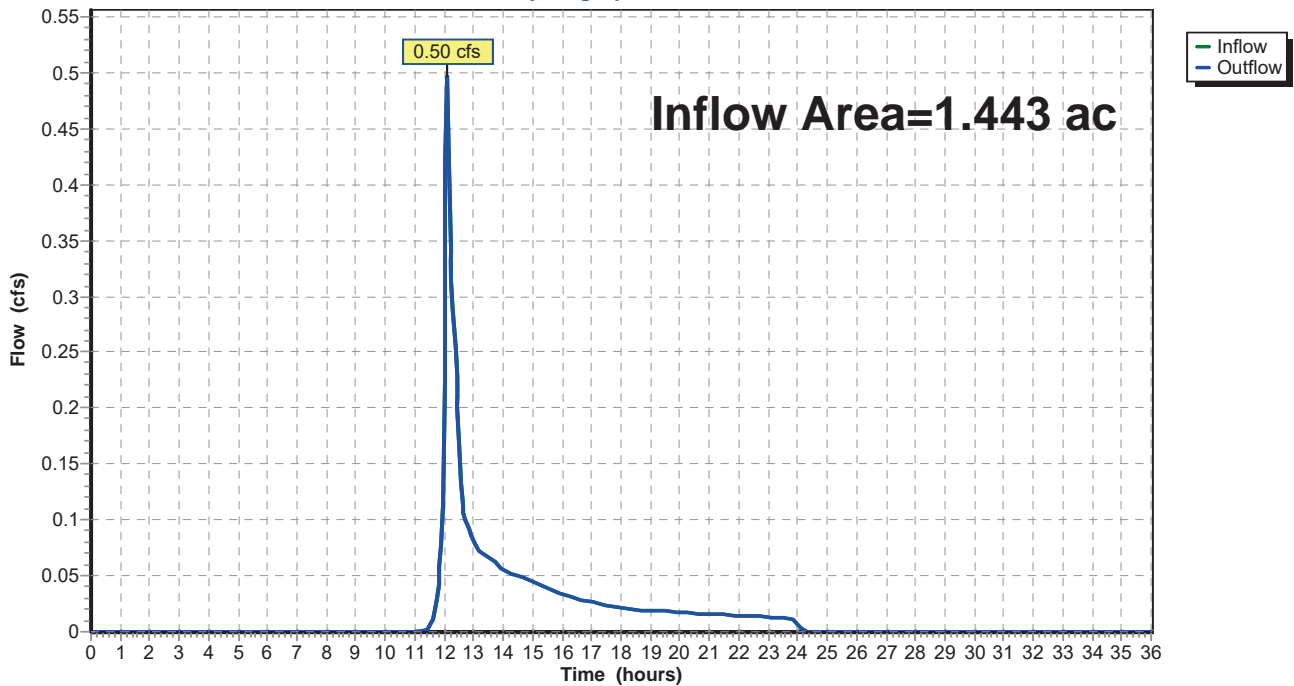
## Summary for Reach 18R: DESIGN LINE

Inflow Area = 1.443 ac, 42.35% Impervious, Inflow Depth = 0.37" for 1-Year event  
Inflow = 0.50 cfs @ 12.10 hrs, Volume= 0.045 af  
Outflow = 0.50 cfs @ 12.10 hrs, Volume= 0.045 af, Atten= 0%, Lag= 0.0 min

Routing by Stor-Ind+Trans method, Time Span= 0.00-36.00 hrs, dt= 0.05 hrs

## Reach 18R: DESIGN LINE

Hydrograph



# Mulberry Subdivision

Prepared by Hildenbrand Engineering, PLLC

HydroCAD® 10.10-6a s/n 11988 © 2020 HydroCAD Software Solutions LLC

Type III 24-hr 1-Year Rainfall=2.59"

Printed 5/1/2023

Page 14

## Summary for Pond 13P: Infiltration

Inflow Area = 0.045 ac, 100.00% Impervious, Inflow Depth = 2.36" for 1-Year event  
 Inflow = 0.11 cfs @ 12.07 hrs, Volume= 0.009 af  
 Outflow = 0.02 cfs @ 11.65 hrs, Volume= 0.009 af, Atten= 84%, Lag= 0.0 min  
 Discarded = 0.02 cfs @ 11.65 hrs, Volume= 0.009 af  
 Primary = 0.00 cfs @ 0.00 hrs, Volume= 0.000 af  
 Routed to Reach 18R : DESIGN LINE

Routing by Stor-Ind method, Time Span= 0.00-36.00 hrs, dt= 0.05 hrs  
 Peak Elev= 2.50' @ 12.54 hrs Surf.Area= 0.002 ac Storage= 0.002 af

Plug-Flow detention time= 30.3 min calculated for 0.009 af (100% of inflow)  
 Center-of-Mass det. time= 30.3 min ( 790.4 - 760.1 )

Volume	Invert	Avail.Storage	Storage Description
#1A	0.00'	0.002 af	<b>6.33'W x 10.50'L x 3.54'H Field A</b> 0.005 af Overall - 0.001 af Embedded = 0.004 af x 40.0% Voids
#2A	0.50'	0.001 af	<b>Cultec R-330XLHD Inside #1</b> Effective Size= 47.8"W x 30.0"H => 7.45 sf x 7.00'L = 52.2 cf Overall Size= 52.0"W x 30.5"H x 8.50'L with 1.50' Overlap Row Length Adjustment= +1.50' x 7.45 sf x 1 rows
		0.003 af	Total Available Storage

Storage Group A created with Chamber Wizard

Device	Routing	Invert	Outlet Devices
#1	Discarded	0.00'	<b>12.000 in/hr Exfiltration over Surface area</b>
#2	Primary	5.00'	<b>24.0" x 24.0" Horiz. Orifice/Grate</b> C= 0.600 Limited to weir flow at low heads

**Discarded OutFlow** Max=0.02 cfs @ 11.65 hrs HW=0.05' (Free Discharge)  
 ↑1=Exfiltration (Exfiltration Controls 0.02 cfs)

**Primary OutFlow** Max=0.00 cfs @ 0.00 hrs HW=0.00' (Free Discharge)  
 ↑2=Orifice/Grate ( Controls 0.00 cfs)

## Mulberry Subdivision

Prepared by Hildenbrand Engineering, PLLC

HydroCAD® 10.10-6a s/n 11988 © 2020 HydroCAD Software Solutions LLC

Type III 24-hr 1-Year Rainfall=2.59"

Printed 5/1/2023

Page 15

### Pond 13P: Infiltration - Chamber Wizard Field A

#### Chamber Model = Cultec R-330XLHD (Cultec Recharger® 330XLHD)

Effective Size= 47.8"W x 30.0"H => 7.45 sf x 7.00'L = 52.2 cf

Overall Size= 52.0"W x 30.5"H x 8.50'L with 1.50' Overlap

Row Length Adjustment= +1.50' x 7.45 sf x 1 rows

1 Chambers/Row x 7.00' Long +1.50' Row Adjustment = 8.50' Row Length +12.0" End Stone x 2 = 10.50' Base Length

1 Rows x 52.0" Wide + 12.0" Side Stone x 2 = 6.33' Base Width

6.0" Stone Base + 30.5" Chamber Height + 6.0" Stone Cover = 3.54' Field Height

1 Chambers x 52.2 cf +1.50' Row Adjustment x 7.45 sf x 1 Rows = 63.3 cf Chamber Storage

235.5 cf Field - 63.3 cf Chambers = 172.2 cf Stone x 40.0% Voids = 68.9 cf Stone Storage

Chamber Storage + Stone Storage = 132.2 cf = 0.003 af

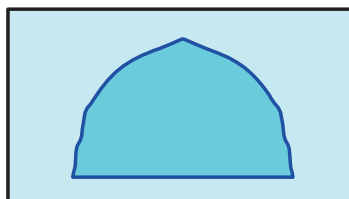
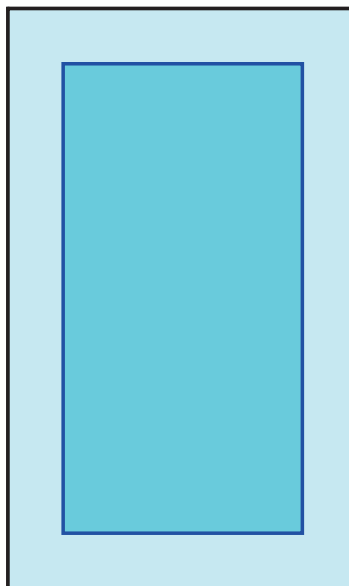
Overall Storage Efficiency = 56.1%

Overall System Size = 10.50' x 6.33' x 3.54'

1 Chambers

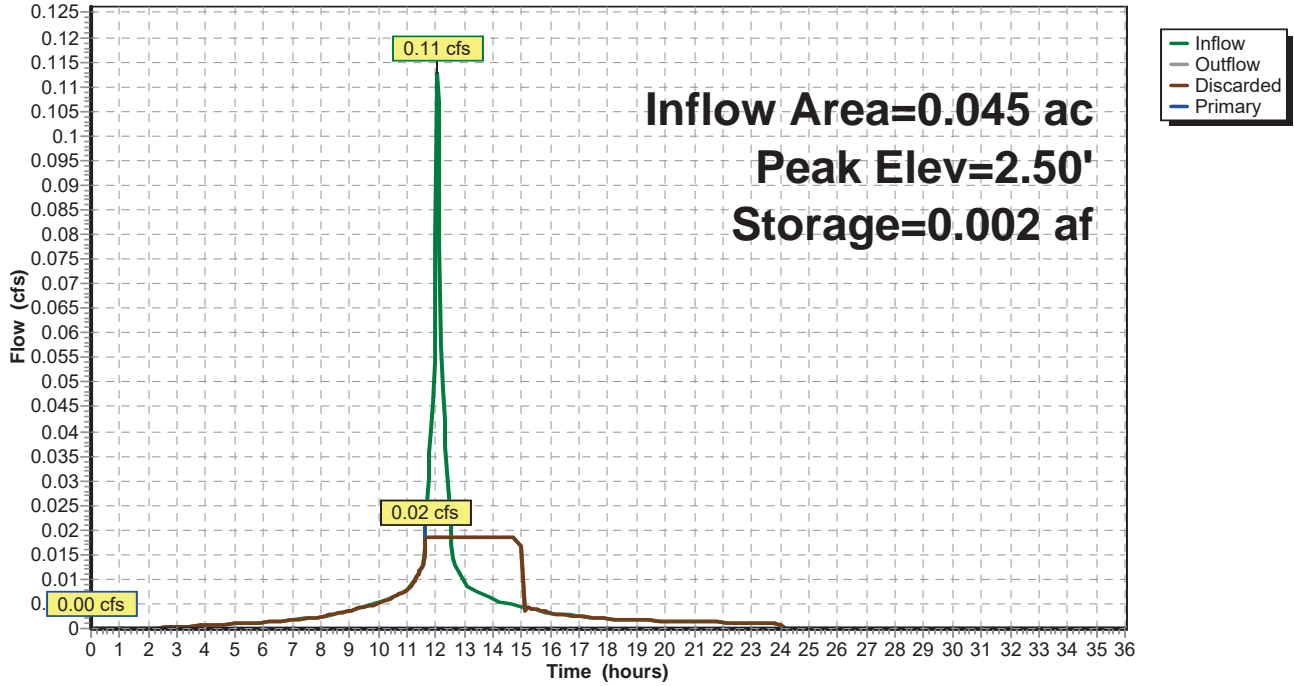
8.7 cy Field

6.4 cy Stone



Pond 13P: Infiltration

Hydrograph



# Mulberry Subdivision

Prepared by Hildenbrand Engineering, PLLC

HydroCAD® 10.10-6a s/n 11988 © 2020 HydroCAD Software Solutions LLC

Type III 24-hr 1-Year Rainfall=2.59"

Printed 5/1/2023

Page 17

## Summary for Pond 14P: Infiltration

Inflow Area = 0.045 ac, 100.00% Impervious, Inflow Depth = 2.36" for 1-Year event  
 Inflow = 0.11 cfs @ 12.07 hrs, Volume= 0.009 af  
 Outflow = 0.02 cfs @ 11.65 hrs, Volume= 0.009 af, Atten= 84%, Lag= 0.0 min  
 Discarded = 0.02 cfs @ 11.65 hrs, Volume= 0.009 af  
 Primary = 0.00 cfs @ 0.00 hrs, Volume= 0.000 af  
 Routed to Reach 18R : DESIGN LINE

Routing by Stor-Ind method, Time Span= 0.00-36.00 hrs, dt= 0.05 hrs  
 Peak Elev= 2.50' @ 12.54 hrs Surf.Area= 0.002 ac Storage= 0.002 af

Plug-Flow detention time= 30.3 min calculated for 0.009 af (100% of inflow)  
 Center-of-Mass det. time= 30.3 min ( 790.4 - 760.1 )

Volume	Invert	Avail.Storage	Storage Description
#1A	0.00'	0.002 af	<b>6.33'W x 10.50'L x 3.54'H Field A</b> 0.005 af Overall - 0.001 af Embedded = 0.004 af x 40.0% Voids
#2A	0.50'	0.001 af	<b>Cultec R-330XLHD Inside #1</b> Effective Size= 47.8"W x 30.0"H => 7.45 sf x 7.00'L = 52.2 cf Overall Size= 52.0"W x 30.5"H x 8.50'L with 1.50' Overlap Row Length Adjustment= +1.50' x 7.45 sf x 1 rows
		0.003 af	Total Available Storage

Storage Group A created with Chamber Wizard

Device	Routing	Invert	Outlet Devices
#1	Discarded	0.00'	<b>12.000 in/hr Exfiltration over Surface area</b>
#2	Primary	5.00'	<b>24.0" x 24.0" Horiz. Orifice/Grate</b> C= 0.600 Limited to weir flow at low heads

**Discarded OutFlow** Max=0.02 cfs @ 11.65 hrs HW=0.05' (Free Discharge)  
 ↑1=Exfiltration (Exfiltration Controls 0.02 cfs)

**Primary OutFlow** Max=0.00 cfs @ 0.00 hrs HW=0.00' (Free Discharge)  
 ↑2=Orifice/Grate ( Controls 0.00 cfs)

## Mulberry Subdivision

Prepared by Hildenbrand Engineering, PLLC

HydroCAD® 10.10-6a s/n 11988 © 2020 HydroCAD Software Solutions LLC

Type III 24-hr 1-Year Rainfall=2.59"

Printed 5/1/2023

Page 18

### Pond 14P: Infiltration - Chamber Wizard Field A

#### Chamber Model = Cultec R-330XLHD (Cultec Recharger® 330XLHD)

Effective Size= 47.8"W x 30.0"H => 7.45 sf x 7.00'L = 52.2 cf

Overall Size= 52.0"W x 30.5"H x 8.50'L with 1.50' Overlap

Row Length Adjustment= +1.50' x 7.45 sf x 1 rows

1 Chambers/Row x 7.00' Long +1.50' Row Adjustment = 8.50' Row Length +12.0" End Stone x 2 = 10.50' Base Length

1 Rows x 52.0" Wide + 12.0" Side Stone x 2 = 6.33' Base Width

6.0" Stone Base + 30.5" Chamber Height + 6.0" Stone Cover = 3.54' Field Height

1 Chambers x 52.2 cf +1.50' Row Adjustment x 7.45 sf x 1 Rows = 63.3 cf Chamber Storage

235.5 cf Field - 63.3 cf Chambers = 172.2 cf Stone x 40.0% Voids = 68.9 cf Stone Storage

Chamber Storage + Stone Storage = 132.2 cf = 0.003 af

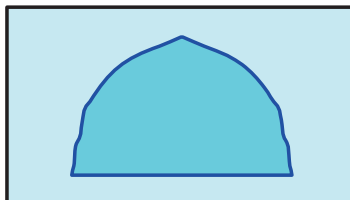
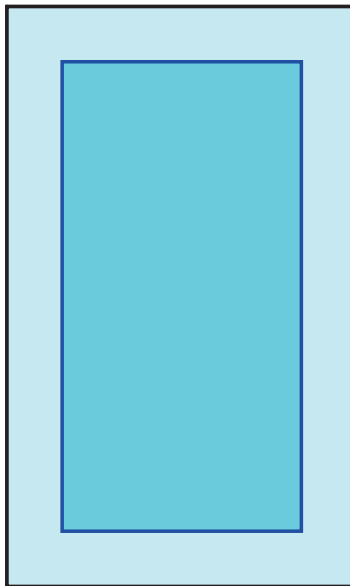
Overall Storage Efficiency = 56.1%

Overall System Size = 10.50' x 6.33' x 3.54'

1 Chambers

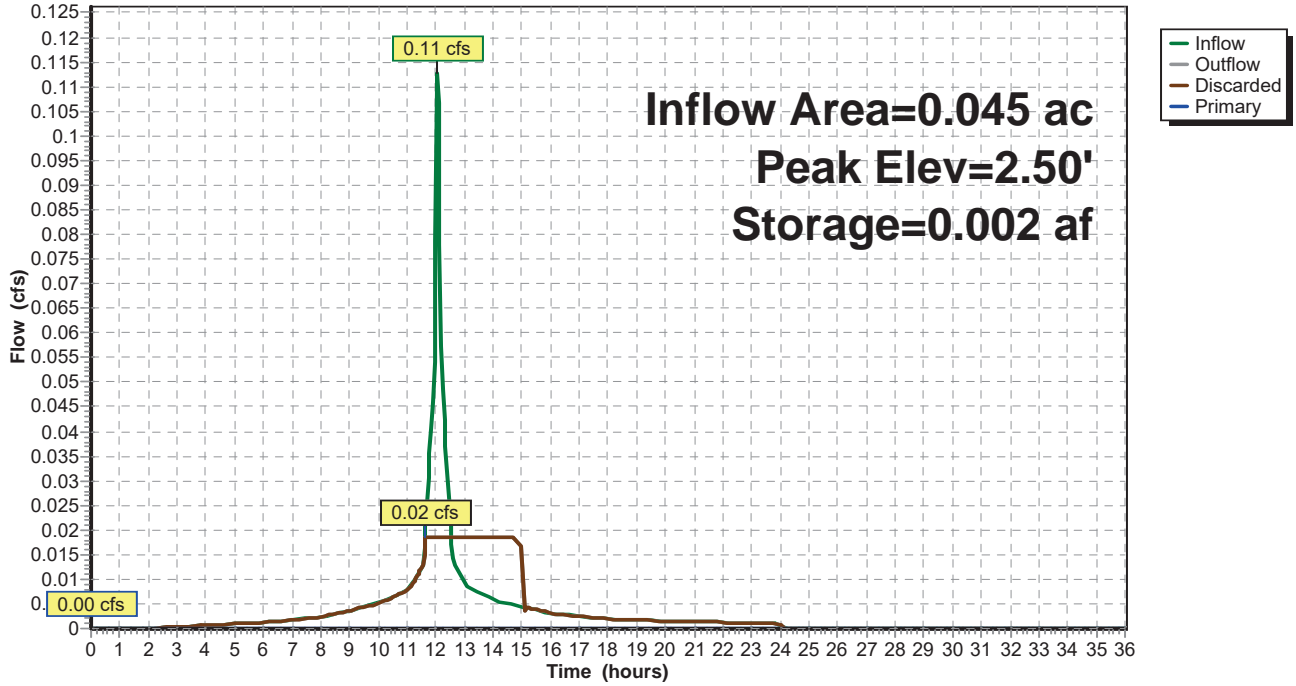
8.7 cy Field

6.4 cy Stone



Pond 14P: Infiltration

Hydrograph





# Mulberry Subdivision

Prepared by Hildenbrand Engineering, PLLC

HydroCAD® 10.10-6a s/n 11988 © 2020 HydroCAD Software Solutions LLC

Type III 24-hr 1-Year Rainfall=2.59"

Printed 5/1/2023

Page 20

## Summary for Pond 15P: Infiltration

Inflow Area = 0.045 ac, 100.00% Impervious, Inflow Depth = 2.36" for 1-Year event  
 Inflow = 0.11 cfs @ 12.07 hrs, Volume= 0.009 af  
 Outflow = 0.02 cfs @ 11.65 hrs, Volume= 0.009 af, Atten= 84%, Lag= 0.0 min  
 Discarded = 0.02 cfs @ 11.65 hrs, Volume= 0.009 af  
 Primary = 0.00 cfs @ 0.00 hrs, Volume= 0.000 af  
 Routed to Reach 18R : DESIGN LINE

Routing by Stor-Ind method, Time Span= 0.00-36.00 hrs, dt= 0.05 hrs  
 Peak Elev= 2.50' @ 12.54 hrs Surf.Area= 0.002 ac Storage= 0.002 af

Plug-Flow detention time= 30.3 min calculated for 0.009 af (100% of inflow)  
 Center-of-Mass det. time= 30.3 min ( 790.4 - 760.1 )

Volume	Invert	Avail.Storage	Storage Description
#1A	0.00'	0.002 af	<b>6.33'W x 10.50'L x 3.54'H Field A</b> 0.005 af Overall - 0.001 af Embedded = 0.004 af x 40.0% Voids
#2A	0.50'	0.001 af	<b>Cultec R-330XLHD Inside #1</b> Effective Size= 47.8"W x 30.0"H => 7.45 sf x 7.00'L = 52.2 cf Overall Size= 52.0"W x 30.5"H x 8.50'L with 1.50' Overlap Row Length Adjustment= +1.50' x 7.45 sf x 1 rows
		0.003 af	Total Available Storage

Storage Group A created with Chamber Wizard

Device	Routing	Invert	Outlet Devices
#1	Discarded	0.00'	<b>12.000 in/hr Exfiltration over Surface area</b>
#2	Primary	5.00'	<b>24.0" x 24.0" Horiz. Orifice/Grate</b> C= 0.600 Limited to weir flow at low heads

**Discarded OutFlow** Max=0.02 cfs @ 11.65 hrs HW=0.05' (Free Discharge)  
 ↑1=Exfiltration (Exfiltration Controls 0.02 cfs)

**Primary OutFlow** Max=0.00 cfs @ 0.00 hrs HW=0.00' (Free Discharge)  
 ↑2=Orifice/Grate ( Controls 0.00 cfs)

## Mulberry Subdivision

Prepared by Hildenbrand Engineering, PLLC

HydroCAD® 10.10-6a s/n 11988 © 2020 HydroCAD Software Solutions LLC

Type III 24-hr 1-Year Rainfall=2.59"

Printed 5/1/2023

Page 21

### Pond 15P: Infiltration - Chamber Wizard Field A

#### Chamber Model = Cultec R-330XLHD (Cultec Recharger® 330XLHD)

Effective Size= 47.8"W x 30.0"H => 7.45 sf x 7.00'L = 52.2 cf

Overall Size= 52.0"W x 30.5"H x 8.50'L with 1.50' Overlap

Row Length Adjustment= +1.50' x 7.45 sf x 1 rows

1 Chambers/Row x 7.00' Long +1.50' Row Adjustment = 8.50' Row Length +12.0" End Stone x 2 = 10.50' Base Length

1 Rows x 52.0" Wide + 12.0" Side Stone x 2 = 6.33' Base Width

6.0" Stone Base + 30.5" Chamber Height + 6.0" Stone Cover = 3.54' Field Height

1 Chambers x 52.2 cf +1.50' Row Adjustment x 7.45 sf x 1 Rows = 63.3 cf Chamber Storage

235.5 cf Field - 63.3 cf Chambers = 172.2 cf Stone x 40.0% Voids = 68.9 cf Stone Storage

Chamber Storage + Stone Storage = 132.2 cf = 0.003 af

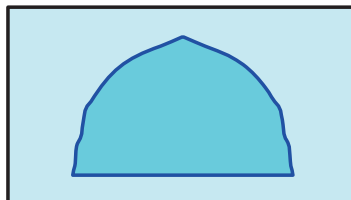
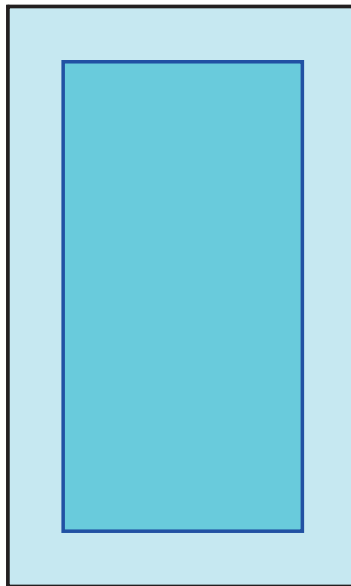
Overall Storage Efficiency = 56.1%

Overall System Size = 10.50' x 6.33' x 3.54'

1 Chambers

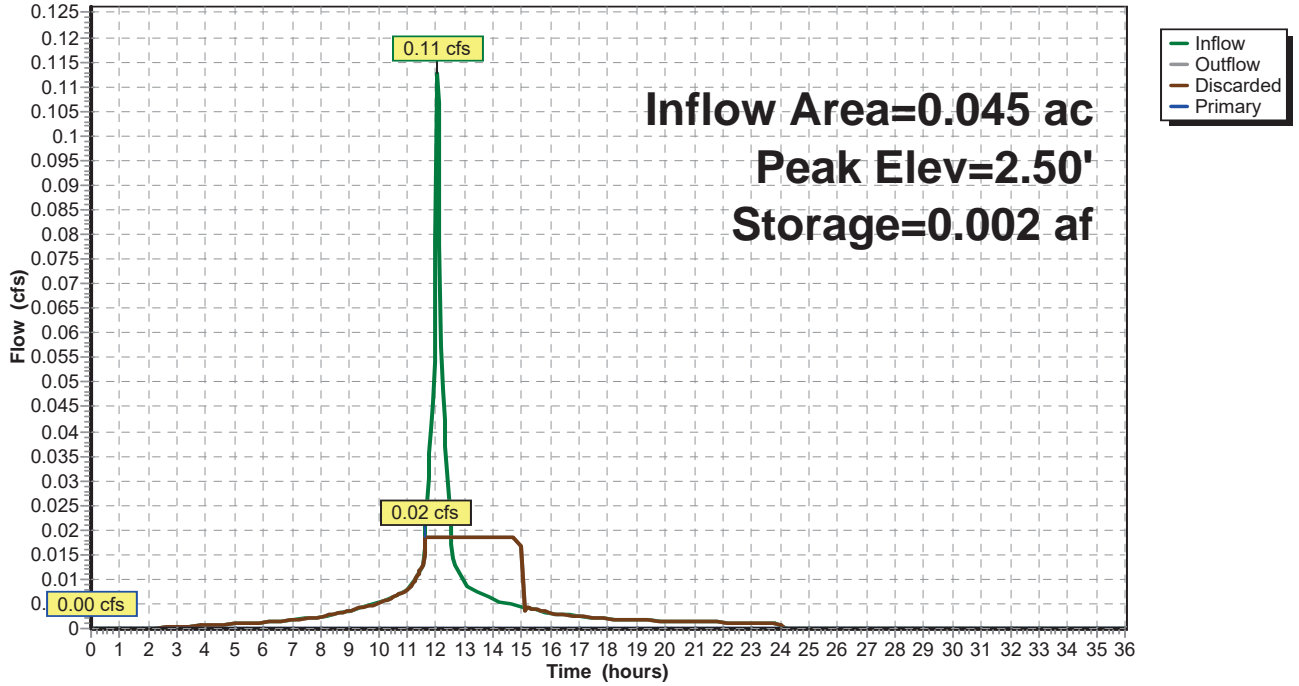
8.7 cy Field

6.4 cy Stone



Pond 15P: Infiltration

Hydrograph



# Mulberry Subdivision

Prepared by Hildenbrand Engineering, PLLC

HydroCAD® 10.10-6a s/n 11988 © 2020 HydroCAD Software Solutions LLC

Type III 24-hr 1-Year Rainfall=2.59"

Printed 5/1/2023

Page 23

## Summary for Pond 16P: Infiltration

Inflow Area = 0.045 ac, 100.00% Impervious, Inflow Depth = 2.36" for 1-Year event  
 Inflow = 0.11 cfs @ 12.07 hrs, Volume= 0.009 af  
 Outflow = 0.02 cfs @ 11.65 hrs, Volume= 0.009 af, Atten= 84%, Lag= 0.0 min  
 Discarded = 0.02 cfs @ 11.65 hrs, Volume= 0.009 af  
 Primary = 0.00 cfs @ 0.00 hrs, Volume= 0.000 af  
 Routed to Reach 18R : DESIGN LINE

Routing by Stor-Ind method, Time Span= 0.00-36.00 hrs, dt= 0.05 hrs  
 Peak Elev= 2.48' @ 12.53 hrs Surf.Area= 0.002 ac Storage= 0.002 af

Plug-Flow detention time= 30.0 min calculated for 0.009 af (100% of inflow)  
 Center-of-Mass det. time= 30.0 min ( 790.2 - 760.1 )

Volume	Invert	Avail.Storage	Storage Description
#1A	0.00'	0.002 af	<b>6.33'W x 10.50'L x 3.54'H Field A</b> 0.005 af Overall - 0.001 af Embedded = 0.004 af x 40.0% Voids
#2A	0.50'	0.001 af	<b>Cultec R-330XLHD Inside #1</b> Effective Size= 47.8"W x 30.0"H => 7.45 sf x 7.00'L = 52.2 cf Overall Size= 52.0"W x 30.5"H x 8.50'L with 1.50' Overlap Row Length Adjustment= +1.50' x 7.45 sf x 1 rows
		0.003 af	Total Available Storage

Storage Group A created with Chamber Wizard

Device	Routing	Invert	Outlet Devices
#1	Discarded	0.00'	<b>12.000 in/hr Exfiltration over Surface area</b>
#2	Primary	5.00'	<b>24.0" x 24.0" Horiz. Orifice/Grate</b> C= 0.600 Limited to weir flow at low heads

**Discarded OutFlow** Max=0.02 cfs @ 11.65 hrs HW=0.05' (Free Discharge)  
 ↑1=Exfiltration (Exfiltration Controls 0.02 cfs)

**Primary OutFlow** Max=0.00 cfs @ 0.00 hrs HW=0.00' (Free Discharge)  
 ↑2=Orifice/Grate ( Controls 0.00 cfs)

**Mulberry Subdivision**

Prepared by Hildenbrand Engineering, PLLC

HydroCAD® 10.10-6a s/n 11988 © 2020 HydroCAD Software Solutions LLC

Type III 24-hr 1-Year Rainfall=2.59"

Printed 5/1/2023

Page 24

**Pond 16P: Infiltration - Chamber Wizard Field A**

**Chamber Model = Cultec R-330XLHD (Cultec Recharger® 330XLHD)**

Effective Size= 47.8"W x 30.0"H => 7.45 sf x 7.00'L = 52.2 cf

Overall Size= 52.0"W x 30.5"H x 8.50'L with 1.50' Overlap

Row Length Adjustment= +1.50' x 7.45 sf x 1 rows

1 Chambers/Row x 7.00' Long +1.50' Row Adjustment = 8.50' Row Length +12.0" End Stone x 2 = 10.50' Base Length

1 Rows x 52.0" Wide + 12.0" Side Stone x 2 = 6.33' Base Width

6.0" Stone Base + 30.5" Chamber Height + 6.0" Stone Cover = 3.54' Field Height

1 Chambers x 52.2 cf +1.50' Row Adjustment x 7.45 sf x 1 Rows = 63.3 cf Chamber Storage

235.5 cf Field - 63.3 cf Chambers = 172.2 cf Stone x 40.0% Voids = 68.9 cf Stone Storage

Chamber Storage + Stone Storage = 132.2 cf = 0.003 af

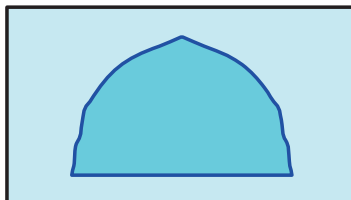
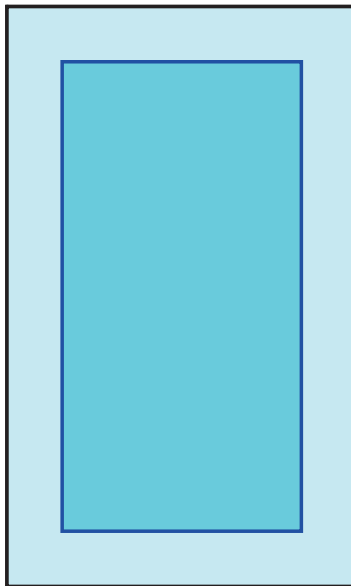
Overall Storage Efficiency = 56.1%

Overall System Size = 10.50' x 6.33' x 3.54'

1 Chambers

8.7 cy Field

6.4 cy Stone



**Mulberry Subdivision**

Prepared by Hildenbrand Engineering, PLLC

HydroCAD® 10.10-6a s/n 11988 © 2020 HydroCAD Software Solutions LLC

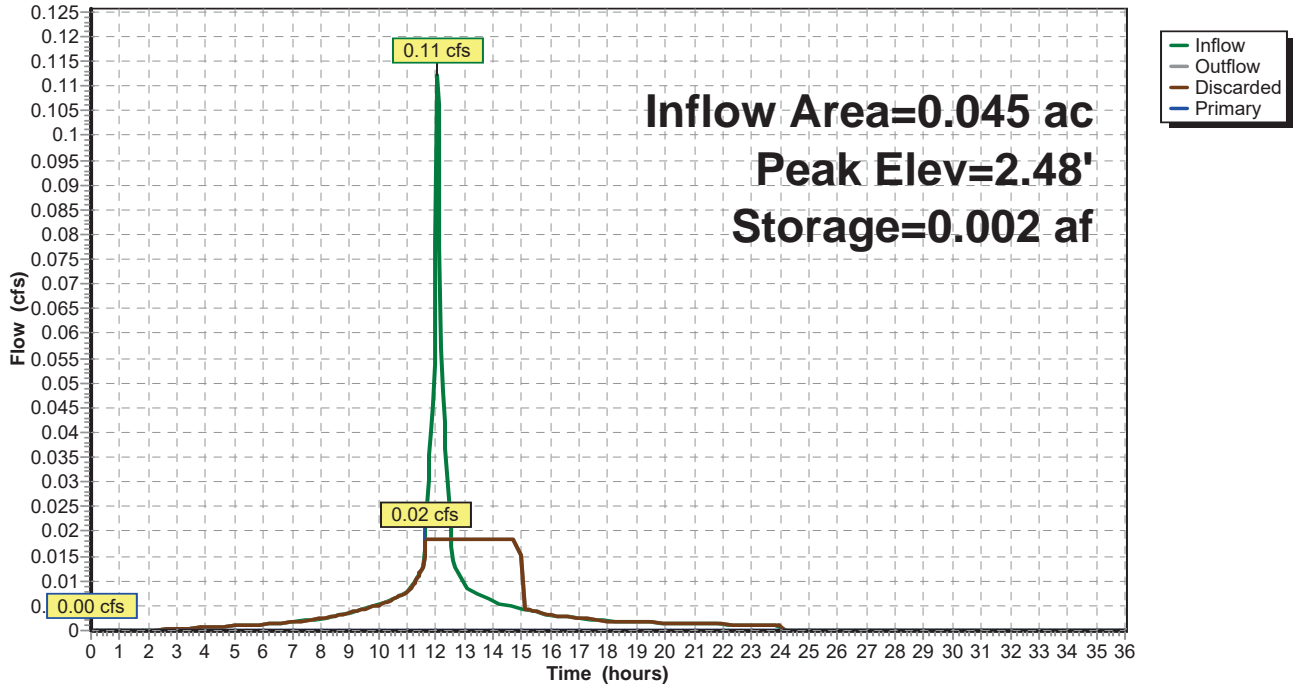
Type III 24-hr 1-Year Rainfall=2.59"

Printed 5/1/2023

Page 25

**Pond 16P: Infiltration**

Hydrograph



# Mulberry Subdivision

Prepared by Hildenbrand Engineering, PLLC

HydroCAD® 10.10-6a s/n 11988 © 2020 HydroCAD Software Solutions LLC

Type III 24-hr 1-Year Rainfall=2.59"

Printed 5/1/2023

Page 26

## Summary for Pond 17P: Infiltration

Inflow Area = 0.182 ac, 100.00% Impervious, Inflow Depth = 2.36" for 1-Year event  
 Inflow = 0.46 cfs @ 12.07 hrs, Volume= 0.036 af  
 Outflow = 0.17 cfs @ 11.90 hrs, Volume= 0.036 af, Atten= 63%, Lag= 0.0 min  
 Discarded = 0.17 cfs @ 11.90 hrs, Volume= 0.036 af  
 Primary = 0.00 cfs @ 0.00 hrs, Volume= 0.000 af  
 Routed to Reach 18R : DESIGN LINE

Routing by Stor-Ind method, Time Span= 0.00-36.00 hrs, dt= 0.05 hrs  
 Peak Elev= 0.63' @ 12.30 hrs Surf.Area= 0.014 ac Storage= 0.004 af

Plug-Flow detention time= 5.0 min calculated for 0.036 af (100% of inflow)  
 Center-of-Mass det. time= 5.0 min ( 765.1 - 760.1 )

Volume	Invert	Avail.Storage	Storage Description
#1A	0.00'	0.013 af	<b>16.00'W x 38.50'L x 3.54'H Field A</b> 0.050 af Overall - 0.019 af Embedded = 0.031 af x 40.0% Voids
#2A	0.50'	0.019 af	<b>Cultec R-330XLHD x 15 Inside #1</b> Effective Size= 47.8"W x 30.0"H => 7.45 sf x 7.00'L = 52.2 cf Overall Size= 52.0"W x 30.5"H x 8.50'L with 1.50' Overlap Row Length Adjustment= +1.50' x 7.45 sf x 3 rows
		0.031 af	Total Available Storage

Storage Group A created with Chamber Wizard

Device	Routing	Invert	Outlet Devices
#1	Discarded	0.00'	<b>12.000 in/hr Exfiltration over Surface area</b>
#2	Primary	5.00'	<b>24.0" x 24.0" Horiz. Orifice/Grate</b> C= 0.600 Limited to weir flow at low heads

**Discarded OutFlow** Max=0.17 cfs @ 11.90 hrs HW=0.05' (Free Discharge)

↑**1=Exfiltration** (Exfiltration Controls 0.17 cfs)

**Primary OutFlow** Max=0.00 cfs @ 0.00 hrs HW=0.00' (Free Discharge)

↑**2=Orifice/Grate** ( Controls 0.00 cfs)

# Mulberry Subdivision

Prepared by Hildenbrand Engineering, PLLC

HydroCAD® 10.10-6a s/n 11988 © 2020 HydroCAD Software Solutions LLC

Type III 24-hr 1-Year Rainfall=2.59"

Printed 5/1/2023

Page 27

## Pond 17P: Infiltration - Chamber Wizard Field A

### Chamber Model = Cultec R-330XLHD (Cultec Recharger® 330XLHD)

Effective Size= 47.8"W x 30.0"H => 7.45 sf x 7.00'L = 52.2 cf

Overall Size= 52.0"W x 30.5"H x 8.50'L with 1.50' Overlap

Row Length Adjustment= +1.50' x 7.45 sf x 3 rows

52.0" Wide + 6.0" Spacing = 58.0" C-C Row Spacing

5 Chambers/Row x 7.00' Long +1.50' Row Adjustment = 36.50' Row Length +12.0" End Stone x 2 = 38.50' Base Length

3 Rows x 52.0" Wide + 6.0" Spacing x 2 + 12.0" Side Stone x 2 = 16.00' Base Width

6.0" Stone Base + 30.5" Chamber Height + 6.0" Stone Cover = 3.54' Field Height

15 Chambers x 52.2 cf +1.50' Row Adjustment x 7.45 sf x 3 Rows = 815.9 cf Chamber Storage

2,181.7 cf Field - 815.9 cf Chambers = 1,365.8 cf Stone x 40.0% Voids = 546.3 cf Stone Storage

Chamber Storage + Stone Storage = 1,362.2 cf = 0.031 af

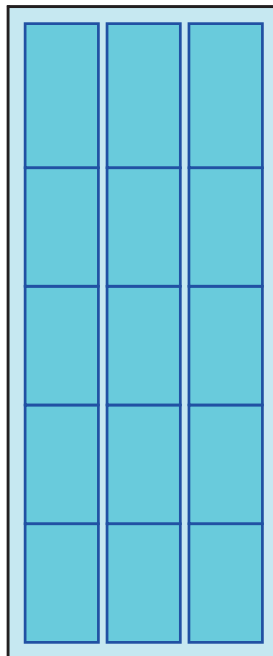
Overall Storage Efficiency = 62.4%

Overall System Size = 38.50' x 16.00' x 3.54'

15 Chambers

80.8 cy Field

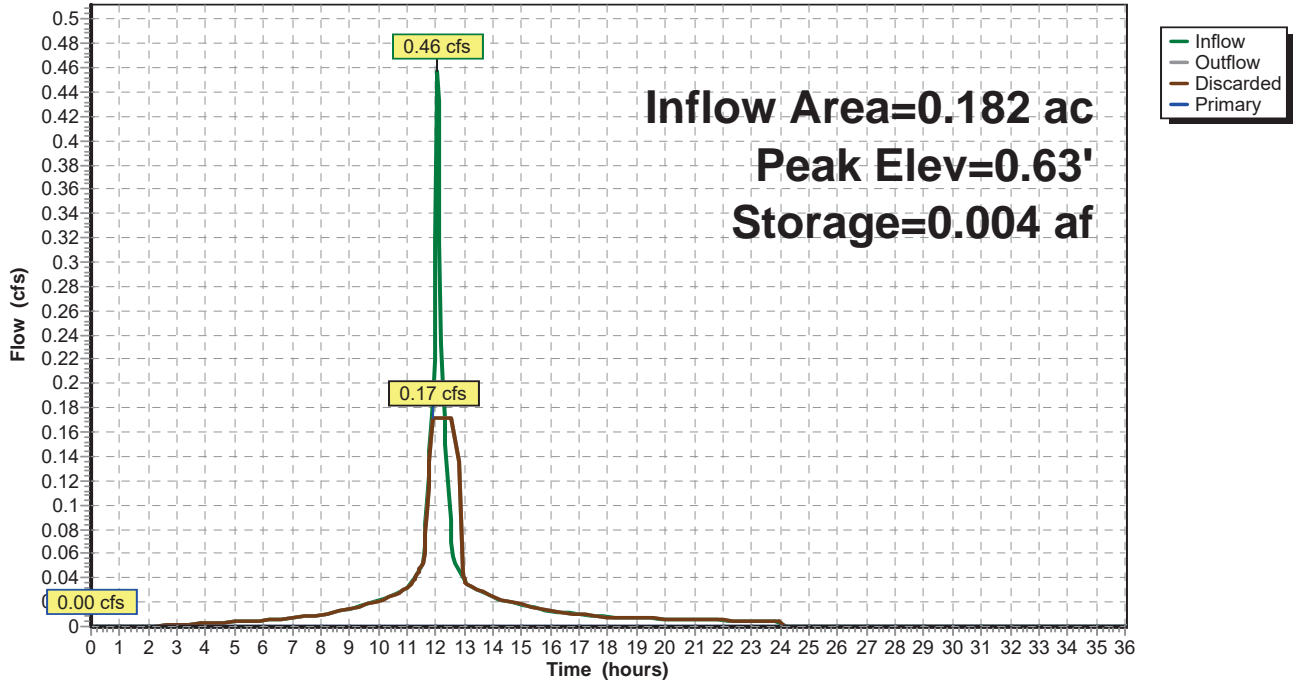
50.6 cy Stone





Pond 17P: Infiltration

Hydrograph



# Mulberry Subdivision

Prepared by Hildenbrand Engineering, PLLC

HydroCAD® 10.10-6a s/n 11988 © 2020 HydroCAD Software Solutions LLC

Type III 24-hr 10-Year Rainfall=4.66"

Printed 5/1/2023

Page 29

## Summary for Subcatchment 2S: Lot #1 Remainder

Runoff = 0.24 cfs @ 12.09 hrs, Volume= 0.018 af, Depth= 1.50"  
 Routed to Reach 18R : DESIGN LINE

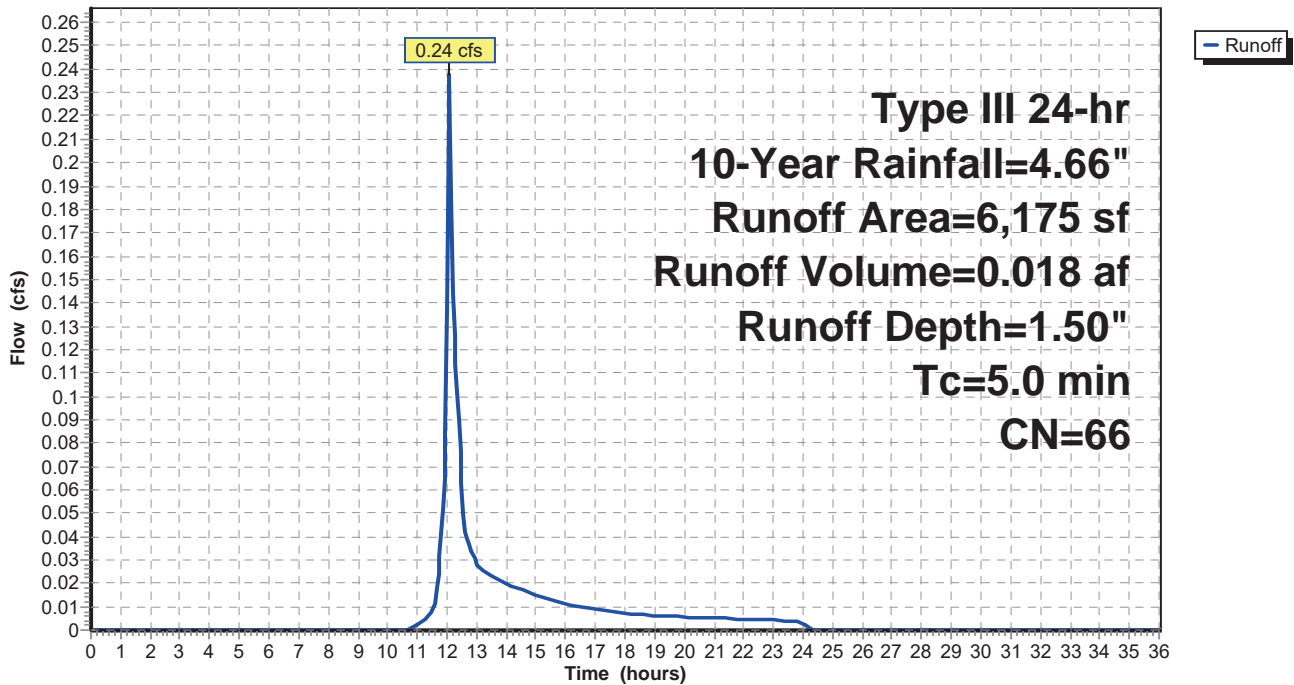
Runoff by SCS TR-20 method, UH=SCS, Weighted-CN, Time Span= 0.00-36.00 hrs, dt= 0.05 hrs  
 Type III 24-hr 10-Year Rainfall=4.66"

	Area (sf)	CN	Description
*	815	98	Driveway
	5,360	61	>75% Grass cover, Good, HSG B
	6,175	66	Weighted Average
	5,360		86.80% Pervious Area
	815		13.20% Impervious Area

Tc (min)	Length (feet)	Slope (ft/ft)	Velocity (ft/sec)	Capacity (cfs)	Description
5.0					Direct Entry,

## Subcatchment 2S: Lot #1 Remainder

Hydrograph



# Mulberry Subdivision

Prepared by Hildenbrand Engineering, PLLC

HydroCAD® 10.10-6a s/n 11988 © 2020 HydroCAD Software Solutions LLC

Type III 24-hr 10-Year Rainfall=4.66"

Printed 5/1/2023

Page 30

## Summary for Subcatchment 3S: Lot #2 Remainder

Runoff = 0.24 cfs @ 12.09 hrs, Volume= 0.018 af, Depth= 1.50"  
 Routed to Reach 18R : DESIGN LINE

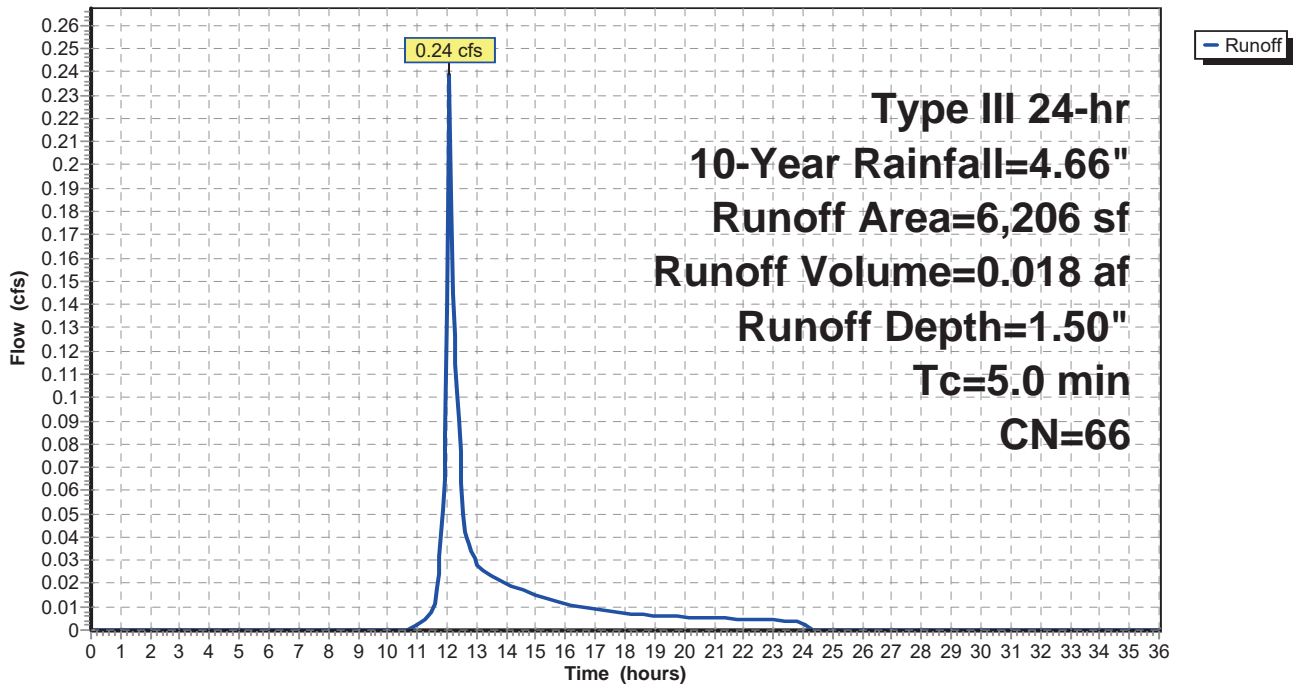
Runoff by SCS TR-20 method, UH=SCS, Weighted-CN, Time Span= 0.00-36.00 hrs, dt= 0.05 hrs  
 Type III 24-hr 10-Year Rainfall=4.66"

	Area (sf)	CN	Description
*	815	98	Driveway
	5,391	61	>75% Grass cover, Good, HSG B
	6,206	66	Weighted Average
	5,391		86.87% Pervious Area
	815		13.13% Impervious Area

Tc (min)	Length (feet)	Slope (ft/ft)	Velocity (ft/sec)	Capacity (cfs)	Description
5.0					Direct Entry,

## Subcatchment 3S: Lot #2 Remainder

Hydrograph



# Mulberry Subdivision

Prepared by Hildenbrand Engineering, PLLC

HydroCAD® 10.10-6a s/n 11988 © 2020 HydroCAD Software Solutions LLC

Type III 24-hr 10-Year Rainfall=4.66"

Printed 5/1/2023

Page 31

## Summary for Subcatchment 4S: Lot #3 Remainder

Runoff = 1.21 cfs @ 12.08 hrs, Volume= 0.087 af, Depth= 2.10"  
 Routed to Reach 18R : DESIGN LINE

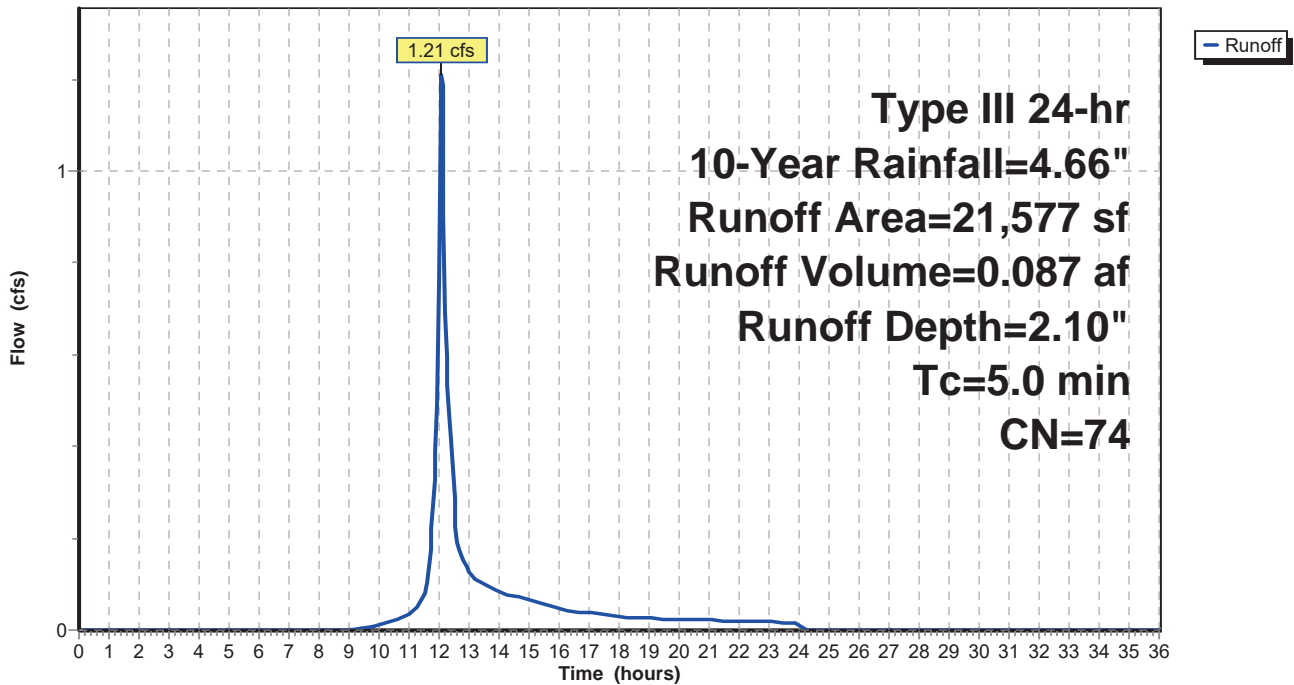
Runoff by SCS TR-20 method, UH=SCS, Weighted-CN, Time Span= 0.00-36.00 hrs, dt= 0.05 hrs  
 Type III 24-hr 10-Year Rainfall=4.66"

	Area (sf)	CN	Description
*	7,583	98	Driveway
	13,994	61	>75% Grass cover, Good, HSG B
	21,577	74	Weighted Average
	13,994		64.86% Pervious Area
	7,583		35.14% Impervious Area

Tc (min)	Length (feet)	Slope (ft/ft)	Velocity (ft/sec)	Capacity (cfs)	Description
5.0					Direct Entry,

## Subcatchment 4S: Lot #3 Remainder

Hydrograph



**Mulberry Subdivision**

Prepared by Hildenbrand Engineering, PLLC

HydroCAD® 10.10-6a s/n 11988 © 2020 HydroCAD Software Solutions LLC

Type III 24-hr 10-Year Rainfall=4.66"

Printed 5/1/2023

Page 32

**Summary for Subcatchment 5S: Lot #4 Remainder**

Runoff = 0.24 cfs @ 12.09 hrs, Volume= 0.018 af, Depth= 1.43"  
 Routed to Reach 18R : DESIGN LINE

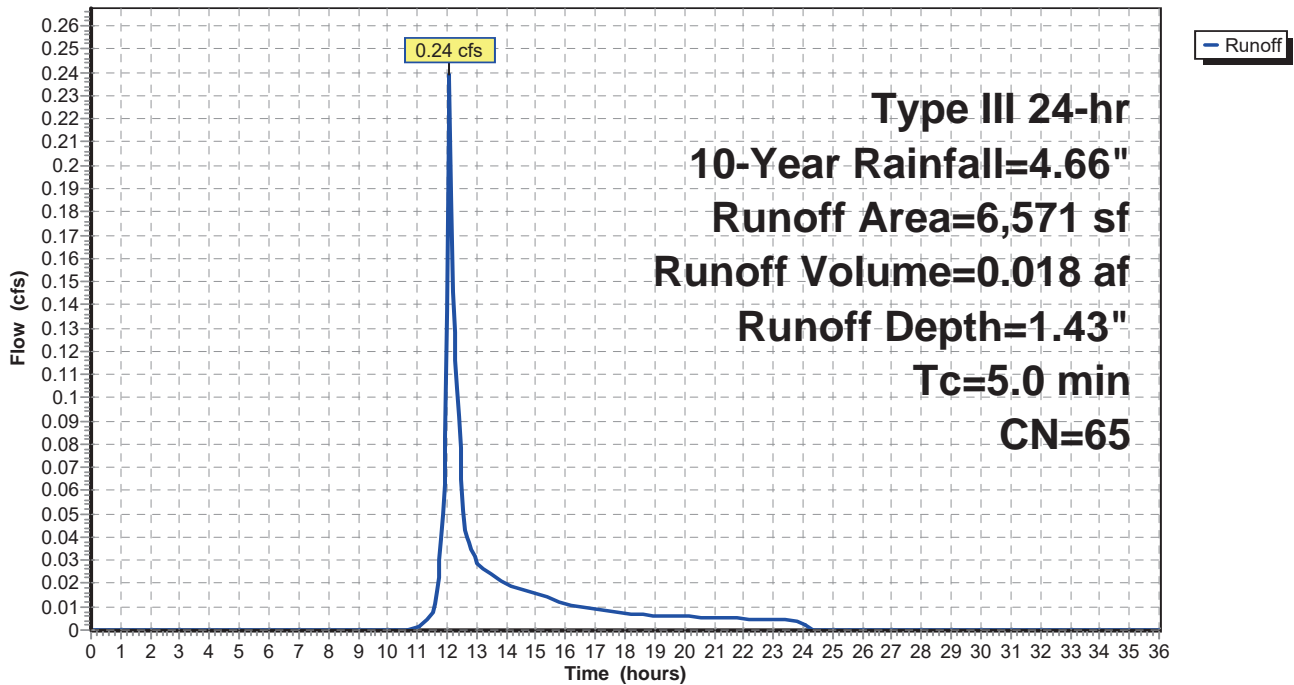
Runoff by SCS TR-20 method, UH=SCS, Weighted-CN, Time Span= 0.00-36.00 hrs, dt= 0.05 hrs  
 Type III 24-hr 10-Year Rainfall=4.66"

	Area (sf)	CN	Description
*	709	98	Driveway
	5,862	61	>75% Grass cover, Good, HSG B
	6,571	65	Weighted Average
	5,862		89.21% Pervious Area
	709		10.79% Impervious Area

Tc (min)	Length (feet)	Slope (ft/ft)	Velocity (ft/sec)	Capacity (cfs)	Description
5.0					Direct Entry,

**Subcatchment 5S: Lot #4 Remainder**

Hydrograph



# Mulberry Subdivision

Prepared by Hildenbrand Engineering, PLLC

HydroCAD® 10.10-6a s/n 11988 © 2020 HydroCAD Software Solutions LLC

Type III 24-hr 10-Year Rainfall=4.66"

Printed 5/1/2023

Page 33

## Summary for Subcatchment 6S: Lot #5 Remainder

Runoff = 0.25 cfs @ 12.09 hrs, Volume= 0.019 af, Depth= 1.50"  
 Routed to Reach 18R : DESIGN LINE

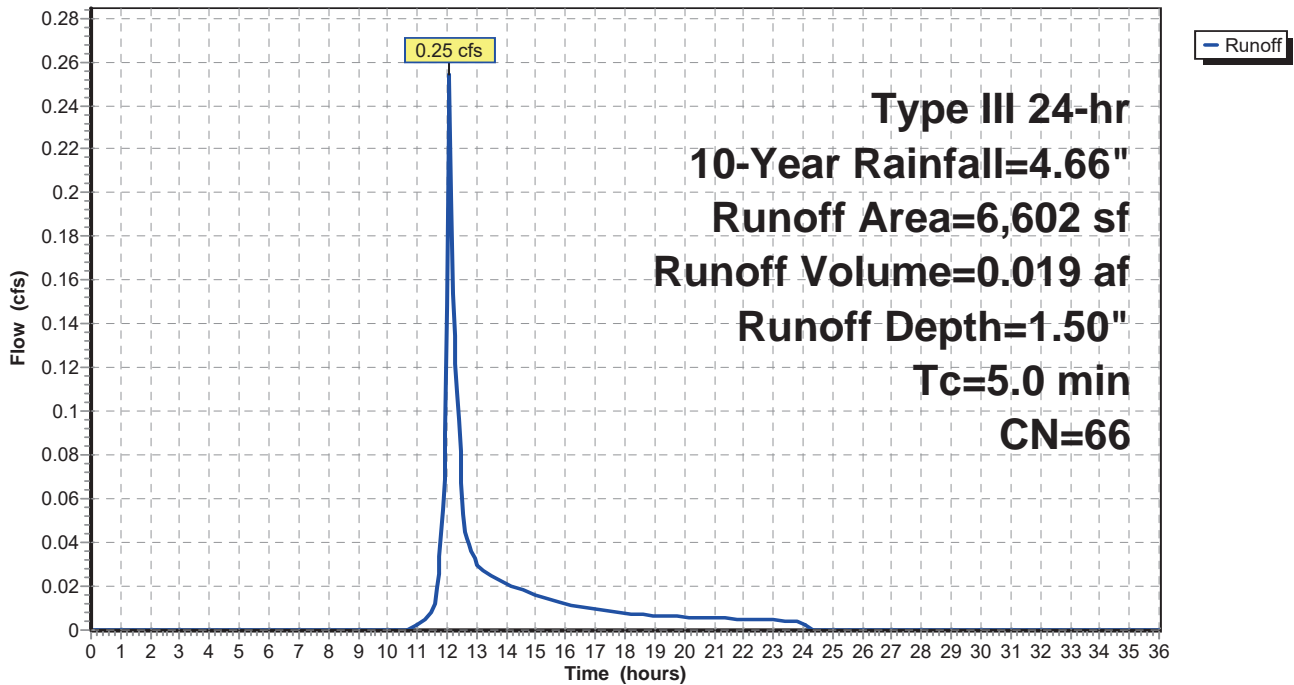
Runoff by SCS TR-20 method, UH=SCS, Weighted-CN, Time Span= 0.00-36.00 hrs, dt= 0.05 hrs  
 Type III 24-hr 10-Year Rainfall=4.66"

	Area (sf)	CN	Description
*	974	98	Driveway
	5,628	61	>75% Grass cover, Good, HSG B
	6,602	66	Weighted Average
	5,628		85.25% Pervious Area
	974		14.75% Impervious Area

Tc (min)	Length (feet)	Slope (ft/ft)	Velocity (ft/sec)	Capacity (cfs)	Description
5.0					Direct Entry,

## Subcatchment 6S: Lot #5 Remainder

Hydrograph



**Mulberry Subdivision**

Prepared by Hildenbrand Engineering, PLLC

HydroCAD® 10.10-6a s/n 11988 © 2020 HydroCAD Software Solutions LLC

Type III 24-hr 10-Year Rainfall=4.66"

Printed 5/1/2023

Page 34

**Summary for Subcatchment 8S: Lot #1 Roof**

Runoff = 0.21 cfs @ 12.07 hrs, Volume= 0.017 af, Depth= 4.42"  
 Routed to Pond 13P : Infiltration

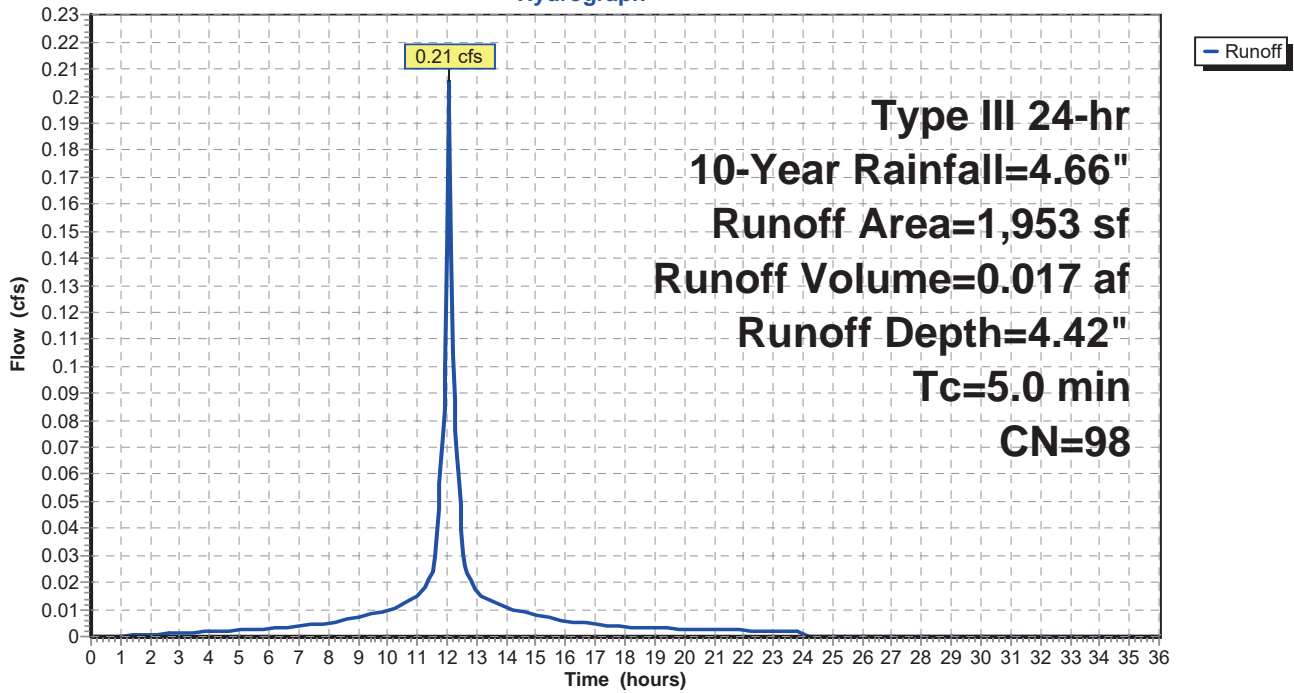
Runoff by SCS TR-20 method, UH=SCS, Weighted-CN, Time Span= 0.00-36.00 hrs, dt= 0.05 hrs  
 Type III 24-hr 10-Year Rainfall=4.66"

Area (sf)	CN	Description
* 1,953	98	Roof Area
1,953		100.00% Impervious Area

Tc (min)	Length (feet)	Slope (ft/ft)	Velocity (ft/sec)	Capacity (cfs)	Description
5.0					Direct Entry,

**Subcatchment 8S: Lot #1 Roof**

Hydrograph



**Mulberry Subdivision**

Prepared by Hildenbrand Engineering, PLLC

HydroCAD® 10.10-6a s/n 11988 © 2020 HydroCAD Software Solutions LLC

Type III 24-hr 10-Year Rainfall=4.66"

Printed 5/1/2023

Page 35

**Summary for Subcatchment 9S: Lot #2 Roof**

Runoff = 0.21 cfs @ 12.07 hrs, Volume= 0.017 af, Depth= 4.42"  
 Routed to Pond 14P : Infiltration

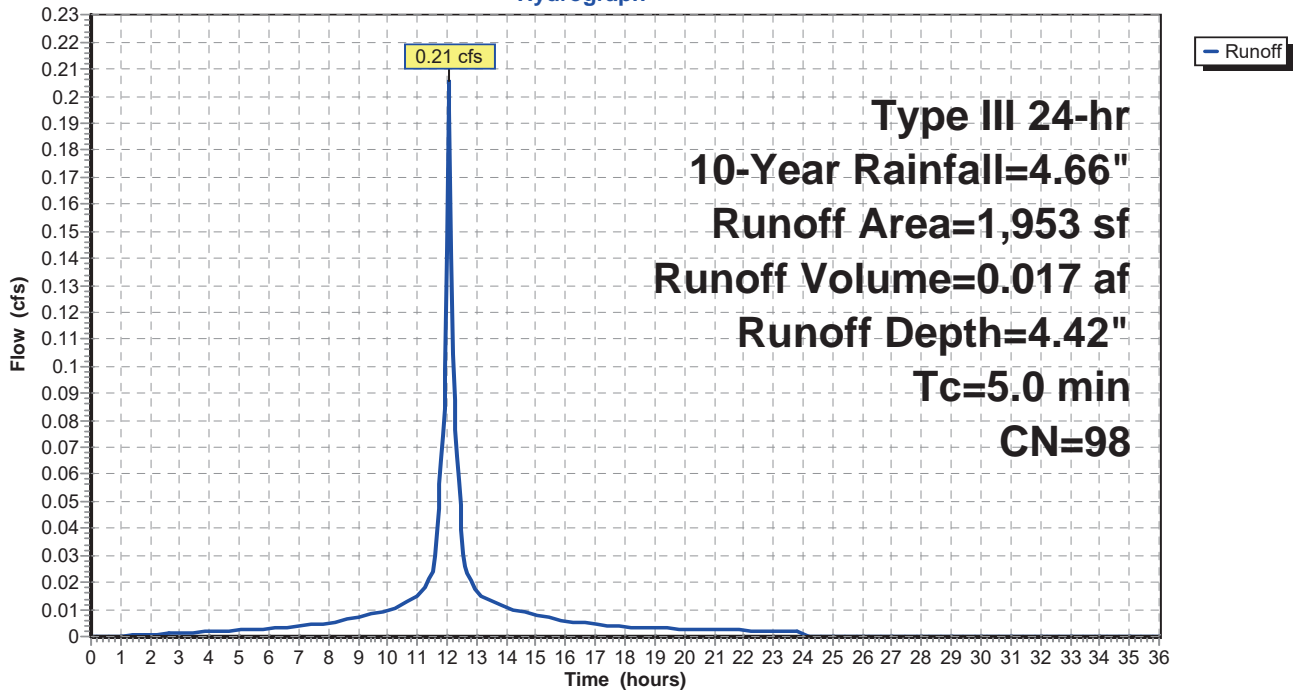
Runoff by SCS TR-20 method, UH=SCS, Weighted-CN, Time Span= 0.00-36.00 hrs, dt= 0.05 hrs  
 Type III 24-hr 10-Year Rainfall=4.66"

Area (sf)	CN	Description
* 1,953	98	Roof Area
1,953		100.00% Impervious Area

Tc (min)	Length (feet)	Slope (ft/ft)	Velocity (ft/sec)	Capacity (cfs)	Description
5.0					Direct Entry,

**Subcatchment 9S: Lot #2 Roof**

Hydrograph





# Mulberry Subdivision

Prepared by Hildenbrand Engineering, PLLC

HydroCAD® 10.10-6a s/n 11988 © 2020 HydroCAD Software Solutions LLC

Type III 24-hr 10-Year Rainfall=4.66"

Printed 5/1/2023

Page 36

## Summary for Subcatchment 10S: Lot #3 Roof

Runoff = 0.83 cfs @ 12.07 hrs, Volume= 0.067 af, Depth= 4.42"  
Routed to Pond 17P : Infiltration

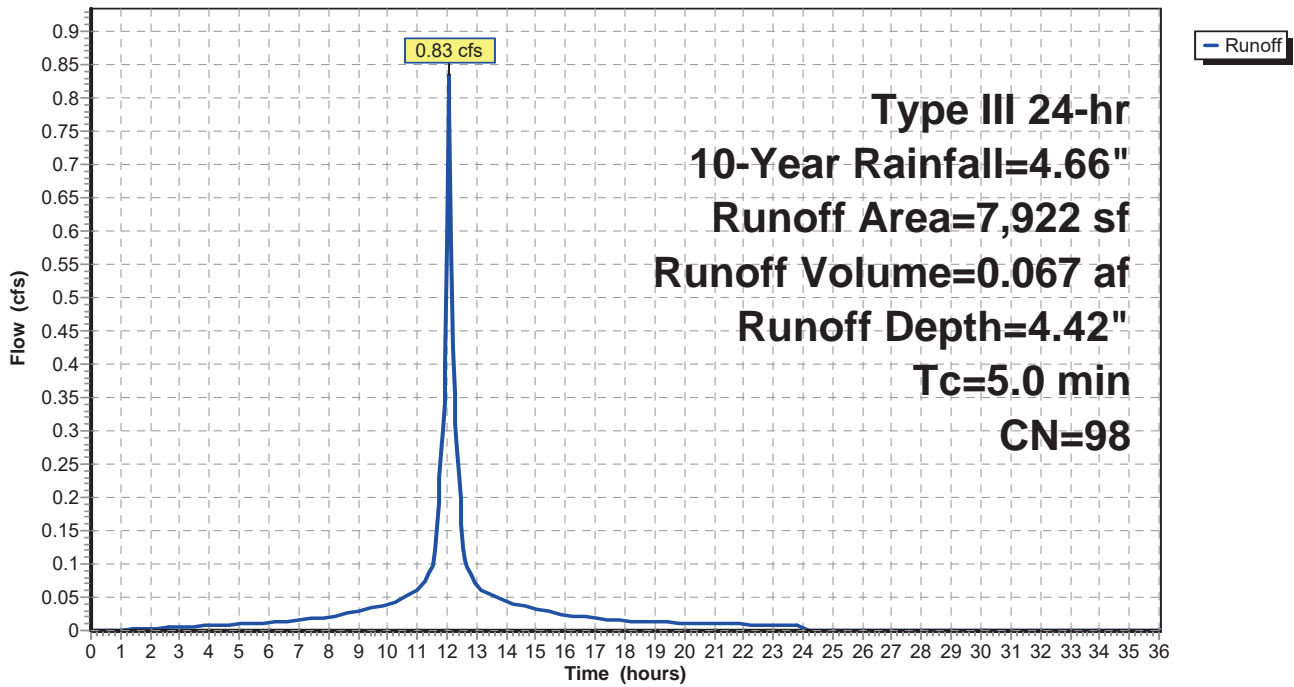
Runoff by SCS TR-20 method, UH=SCS, Weighted-CN, Time Span= 0.00-36.00 hrs, dt= 0.05 hrs  
Type III 24-hr 10-Year Rainfall=4.66"

Area (sf)	CN	Description
* 7,922	98	Roof Area
7,922		100.00% Impervious Area

Tc (min)	Length (feet)	Slope (ft/ft)	Velocity (ft/sec)	Capacity (cfs)	Description
5.0					Direct Entry,

## Subcatchment 10S: Lot #3 Roof

Hydrograph



# Mulberry Subdivision

Prepared by Hildenbrand Engineering, PLLC

HydroCAD® 10.10-6a s/n 11988 © 2020 HydroCAD Software Solutions LLC

Type III 24-hr 10-Year Rainfall=4.66"

Printed 5/1/2023

Page 37

## Summary for Subcatchment 11S: Lot #4 Roof

Runoff = 0.21 cfs @ 12.07 hrs, Volume= 0.017 af, Depth= 4.42"  
Routed to Pond 15P : Infiltration

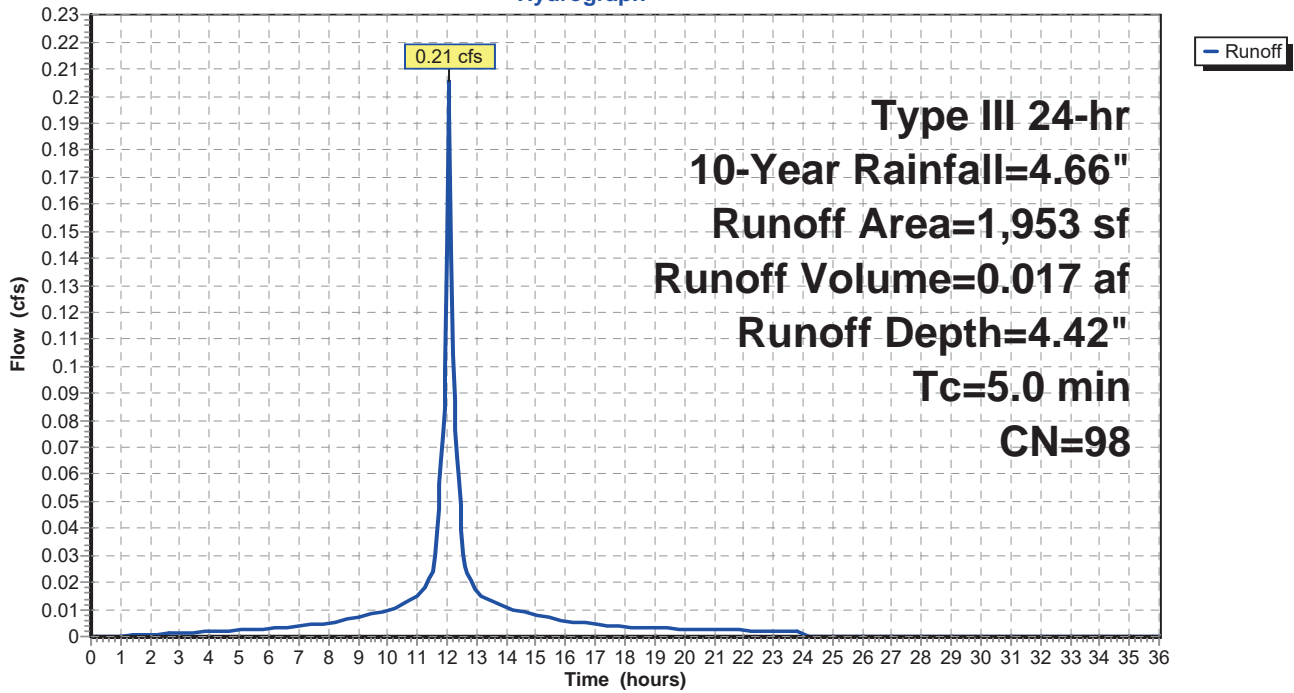
Runoff by SCS TR-20 method, UH=SCS, Weighted-CN, Time Span= 0.00-36.00 hrs, dt= 0.05 hrs  
Type III 24-hr 10-Year Rainfall=4.66"

Area (sf)	CN	Description
* 1,953	98	Roof Area
1,953		100.00% Impervious Area

Tc (min)	Length (feet)	Slope (ft/ft)	Velocity (ft/sec)	Capacity (cfs)	Description
5.0					Direct Entry,

## Subcatchment 11S: Lot #4 Roof

Hydrograph



# Mulberry Subdivision

Prepared by Hildenbrand Engineering, PLLC

HydroCAD® 10.10-6a s/n 11988 © 2020 HydroCAD Software Solutions LLC

Type III 24-hr 10-Year Rainfall=4.66"

Printed 5/1/2023

Page 38

## Summary for Subcatchment 12S: Lot #5 Roof

Runoff = 0.20 cfs @ 12.07 hrs, Volume= 0.016 af, Depth= 4.42"  
Routed to Pond 16P : Infiltration

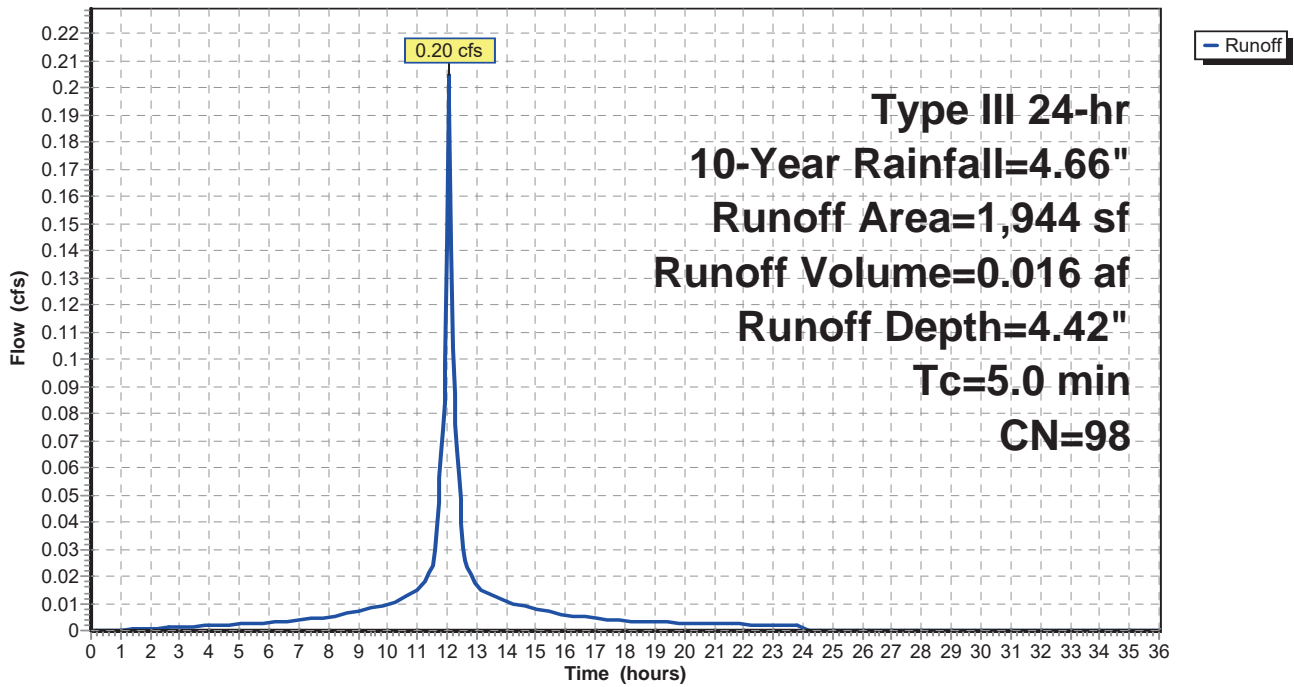
Runoff by SCS TR-20 method, UH=SCS, Weighted-CN, Time Span= 0.00-36.00 hrs, dt= 0.05 hrs  
Type III 24-hr 10-Year Rainfall=4.66"

Area (sf)	CN	Description
* 1,944	98	Roof Area
1,944		100.00% Impervious Area

Tc (min)	Length (feet)	Slope (ft/ft)	Velocity (ft/sec)	Capacity (cfs)	Description
5.0					Direct Entry,

### Subcatchment 12S: Lot #5 Roof

Hydrograph



# Mulberry Subdivision

Prepared by Hildenbrand Engineering, PLLC

HydroCAD® 10.10-6a s/n 11988 © 2020 HydroCAD Software Solutions LLC

Type III 24-hr 10-Year Rainfall=4.66"

Printed 5/1/2023

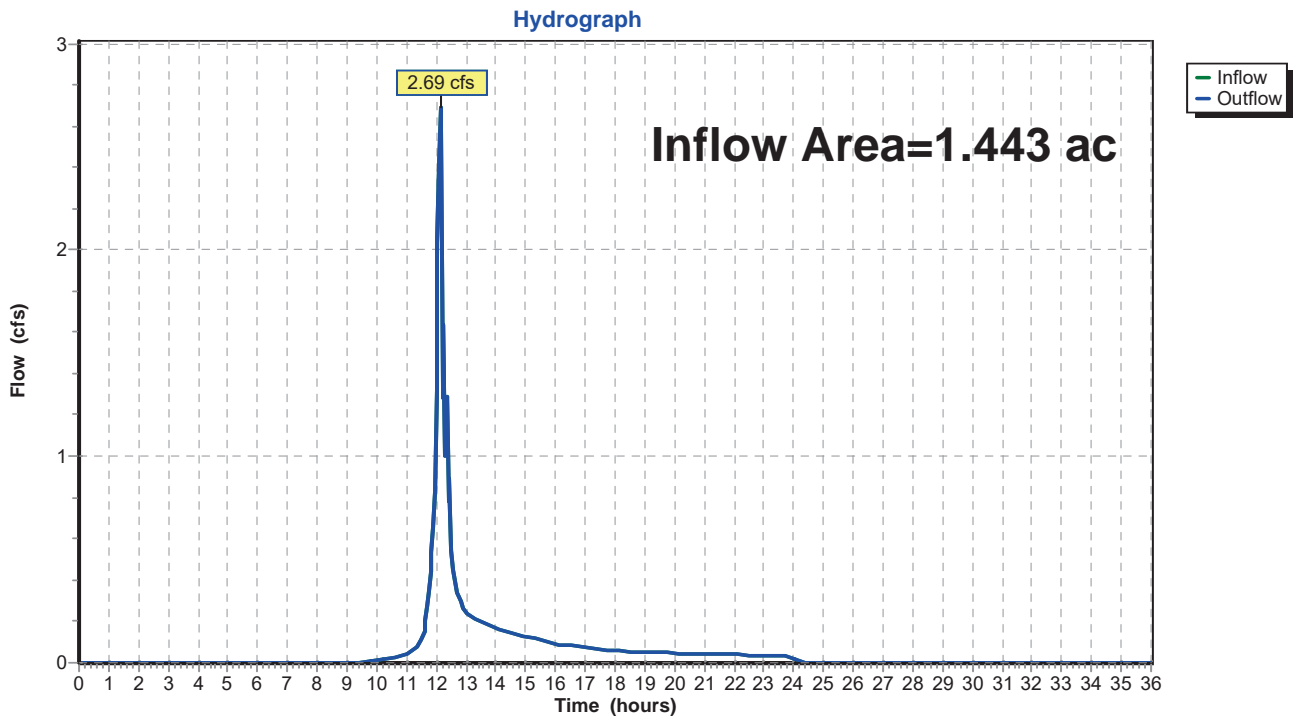
Page 39

## Summary for Reach 18R: DESIGN LINE

Inflow Area = 1.443 ac, 42.35% Impervious, Inflow Depth = 1.41" for 10-Year event  
Inflow = 2.69 cfs @ 12.13 hrs, Volume= 0.169 af  
Outflow = 2.69 cfs @ 12.13 hrs, Volume= 0.169 af, Atten= 0%, Lag= 0.0 min

Routing by Stor-Ind+Trans method, Time Span= 0.00-36.00 hrs, dt= 0.05 hrs

## Reach 18R: DESIGN LINE



# Mulberry Subdivision

Prepared by Hildenbrand Engineering, PLLC

HydroCAD® 10.10-6a s/n 11988 © 2020 HydroCAD Software Solutions LLC

Type III 24-hr 10-Year Rainfall=4.66"

Printed 5/1/2023

Page 40

## Summary for Pond 13P: Infiltration

Inflow Area = 0.045 ac, 100.00% Impervious, Inflow Depth = 4.42" for 10-Year event  
 Inflow = 0.21 cfs @ 12.07 hrs, Volume= 0.017 af  
 Outflow = 0.25 cfs @ 12.15 hrs, Volume= 0.017 af, Atten= 0%, Lag= 4.5 min  
 Discarded = 0.02 cfs @ 11.30 hrs, Volume= 0.014 af  
 Primary = 0.23 cfs @ 12.15 hrs, Volume= 0.003 af  
 Routed to Reach 18R : DESIGN LINE

Routing by Stor-Ind method, Time Span= 0.00-36.00 hrs, dt= 0.05 hrs  
 Peak Elev= 5.04' @ 12.15 hrs Surf.Area= 0.002 ac Storage= 0.003 af

Plug-Flow detention time= 37.1 min calculated for 0.017 af (100% of inflow)  
 Center-of-Mass det. time= 37.0 min ( 785.3 - 748.3 )

Volume	Invert	Avail.Storage	Storage Description
#1A	0.00'	0.002 af	<b>6.33'W x 10.50'L x 3.54'H Field A</b> 0.005 af Overall - 0.001 af Embedded = 0.004 af x 40.0% Voids
#2A	0.50'	0.001 af	<b>Cultec R-330XLHD Inside #1</b> Effective Size= 47.8"W x 30.0"H => 7.45 sf x 7.00'L = 52.2 cf Overall Size= 52.0"W x 30.5"H x 8.50'L with 1.50' Overlap Row Length Adjustment= +1.50' x 7.45 sf x 1 rows
		0.003 af	Total Available Storage

Storage Group A created with Chamber Wizard

Device	Routing	Invert	Outlet Devices
#1	Discarded	0.00'	<b>12.000 in/hr Exfiltration over Surface area</b>
#2	Primary	5.00'	<b>24.0" x 24.0" Horiz. Orifice/Grate</b> C= 0.600 Limited to weir flow at low heads

**Discarded OutFlow** Max=0.02 cfs @ 11.30 hrs HW=0.05' (Free Discharge)  
 ↑**1=Exfiltration** (Exfiltration Controls 0.02 cfs)

**Primary OutFlow** Max=0.18 cfs @ 12.15 hrs HW=5.04' (Free Discharge)  
 ↑**2=Orifice/Grate** (Weir Controls 0.18 cfs @ 0.63 fps)

**Mulberry Subdivision**

Prepared by Hildenbrand Engineering, PLLC

HydroCAD® 10.10-6a s/n 11988 © 2020 HydroCAD Software Solutions LLC

Type III 24-hr 10-Year Rainfall=4.66"

Printed 5/1/2023

Page 41

**Pond 13P: Infiltration - Chamber Wizard Field A**

**Chamber Model = Cultec R-330XLHD (Cultec Recharger® 330XLHD)**

Effective Size= 47.8"W x 30.0"H => 7.45 sf x 7.00'L = 52.2 cf

Overall Size= 52.0"W x 30.5"H x 8.50'L with 1.50' Overlap

Row Length Adjustment= +1.50' x 7.45 sf x 1 rows

1 Chambers/Row x 7.00' Long +1.50' Row Adjustment = 8.50' Row Length +12.0" End Stone x 2 = 10.50' Base Length

1 Rows x 52.0" Wide + 12.0" Side Stone x 2 = 6.33' Base Width

6.0" Stone Base + 30.5" Chamber Height + 6.0" Stone Cover = 3.54' Field Height

1 Chambers x 52.2 cf +1.50' Row Adjustment x 7.45 sf x 1 Rows = 63.3 cf Chamber Storage

235.5 cf Field - 63.3 cf Chambers = 172.2 cf Stone x 40.0% Voids = 68.9 cf Stone Storage

Chamber Storage + Stone Storage = 132.2 cf = 0.003 af

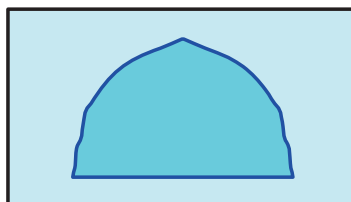
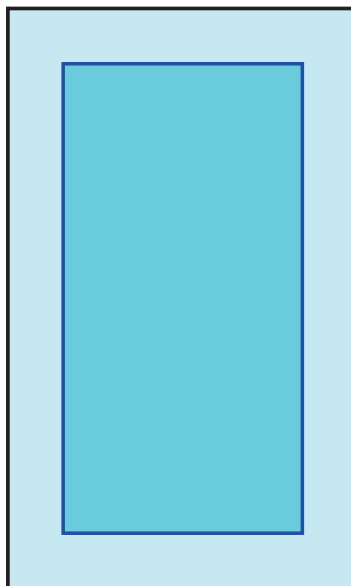
Overall Storage Efficiency = 56.1%

Overall System Size = 10.50' x 6.33' x 3.54'

1 Chambers

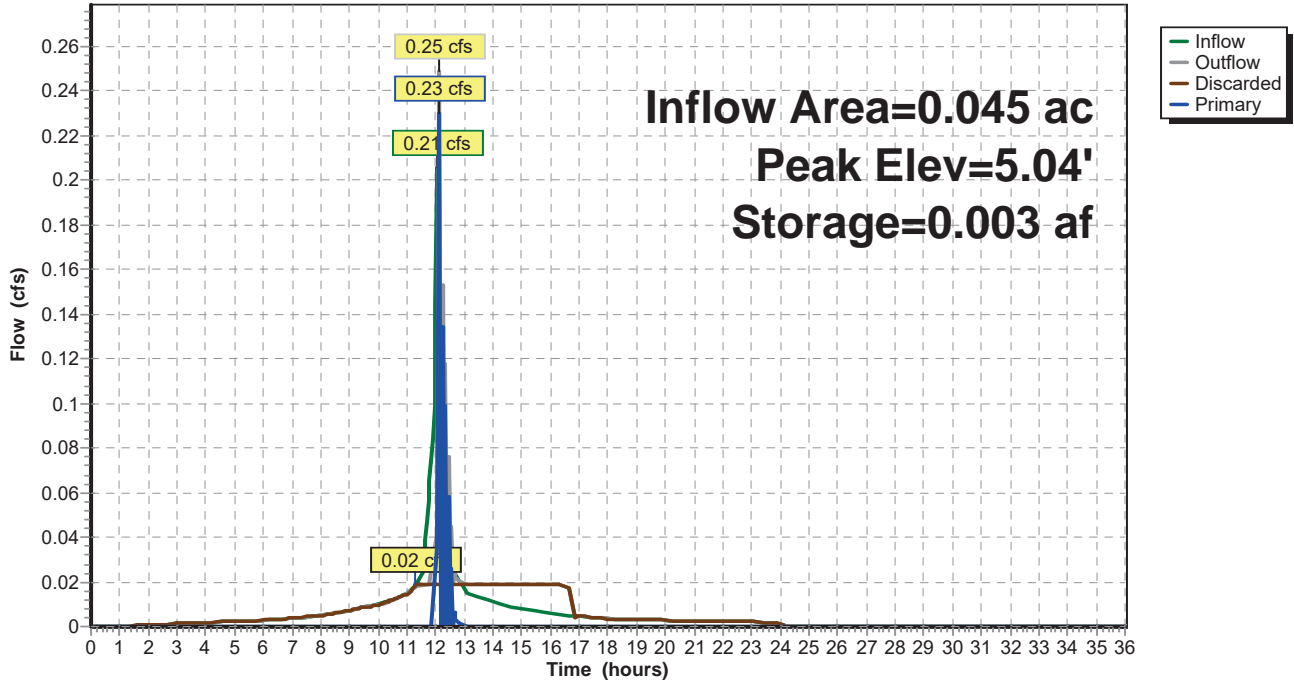
8.7 cy Field

6.4 cy Stone



Pond 13P: Infiltration

Hydrograph



# Mulberry Subdivision

Prepared by Hildenbrand Engineering, PLLC

HydroCAD® 10.10-6a s/n 11988 © 2020 HydroCAD Software Solutions LLC

Type III 24-hr 10-Year Rainfall=4.66"

Printed 5/1/2023

Page 43

## Summary for Pond 14P: Infiltration

Inflow Area = 0.045 ac, 100.00% Impervious, Inflow Depth = 4.42" for 10-Year event  
 Inflow = 0.21 cfs @ 12.07 hrs, Volume= 0.017 af  
 Outflow = 0.25 cfs @ 12.15 hrs, Volume= 0.017 af, Atten= 0%, Lag= 4.5 min  
 Discarded = 0.02 cfs @ 11.30 hrs, Volume= 0.014 af  
 Primary = 0.23 cfs @ 12.15 hrs, Volume= 0.003 af  
 Routed to Reach 18R : DESIGN LINE

Routing by Stor-Ind method, Time Span= 0.00-36.00 hrs, dt= 0.05 hrs  
 Peak Elev= 5.04' @ 12.15 hrs Surf.Area= 0.002 ac Storage= 0.003 af

Plug-Flow detention time= 37.1 min calculated for 0.017 af (100% of inflow)  
 Center-of-Mass det. time= 37.0 min ( 785.3 - 748.3 )

Volume	Invert	Avail.Storage	Storage Description
#1A	0.00'	0.002 af	<b>6.33'W x 10.50'L x 3.54'H Field A</b> 0.005 af Overall - 0.001 af Embedded = 0.004 af x 40.0% Voids
#2A	0.50'	0.001 af	<b>Cultec R-330XLHD Inside #1</b> Effective Size= 47.8"W x 30.0"H => 7.45 sf x 7.00'L = 52.2 cf Overall Size= 52.0"W x 30.5"H x 8.50'L with 1.50' Overlap Row Length Adjustment= +1.50' x 7.45 sf x 1 rows
		0.003 af	Total Available Storage

Storage Group A created with Chamber Wizard

Device	Routing	Invert	Outlet Devices
#1	Discarded	0.00'	<b>12.000 in/hr Exfiltration over Surface area</b>
#2	Primary	5.00'	<b>24.0" x 24.0" Horiz. Orifice/Grate</b> C= 0.600 Limited to weir flow at low heads

**Discarded OutFlow** Max=0.02 cfs @ 11.30 hrs HW=0.05' (Free Discharge)  
 ↑**1=Exfiltration** (Exfiltration Controls 0.02 cfs)

**Primary OutFlow** Max=0.18 cfs @ 12.15 hrs HW=5.04' (Free Discharge)  
 ↑**2=Orifice/Grate** (Weir Controls 0.18 cfs @ 0.63 fps)



**Mulberry Subdivision**

Prepared by Hildenbrand Engineering, PLLC

HydroCAD® 10.10-6a s/n 11988 © 2020 HydroCAD Software Solutions LLC

Type III 24-hr 10-Year Rainfall=4.66"

Printed 5/1/2023

Page 44

**Pond 14P: Infiltration - Chamber Wizard Field A**

**Chamber Model = Cultec R-330XLHD (Cultec Recharger® 330XLHD)**

Effective Size= 47.8"W x 30.0"H => 7.45 sf x 7.00'L = 52.2 cf

Overall Size= 52.0"W x 30.5"H x 8.50'L with 1.50' Overlap

Row Length Adjustment= +1.50' x 7.45 sf x 1 rows

1 Chambers/Row x 7.00' Long +1.50' Row Adjustment = 8.50' Row Length +12.0" End Stone x 2 = 10.50' Base Length

1 Rows x 52.0" Wide + 12.0" Side Stone x 2 = 6.33' Base Width

6.0" Stone Base + 30.5" Chamber Height + 6.0" Stone Cover = 3.54' Field Height

1 Chambers x 52.2 cf +1.50' Row Adjustment x 7.45 sf x 1 Rows = 63.3 cf Chamber Storage

235.5 cf Field - 63.3 cf Chambers = 172.2 cf Stone x 40.0% Voids = 68.9 cf Stone Storage

Chamber Storage + Stone Storage = 132.2 cf = 0.003 af

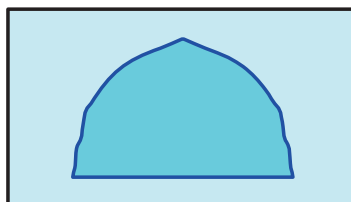
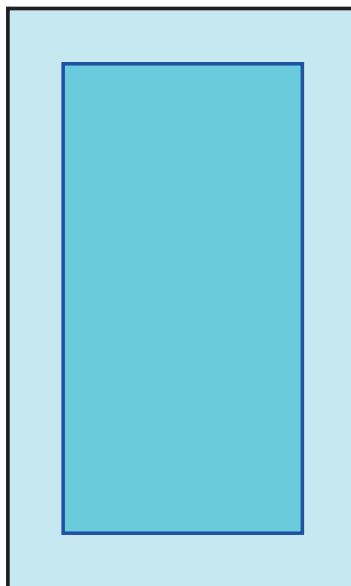
Overall Storage Efficiency = 56.1%

Overall System Size = 10.50' x 6.33' x 3.54'

1 Chambers

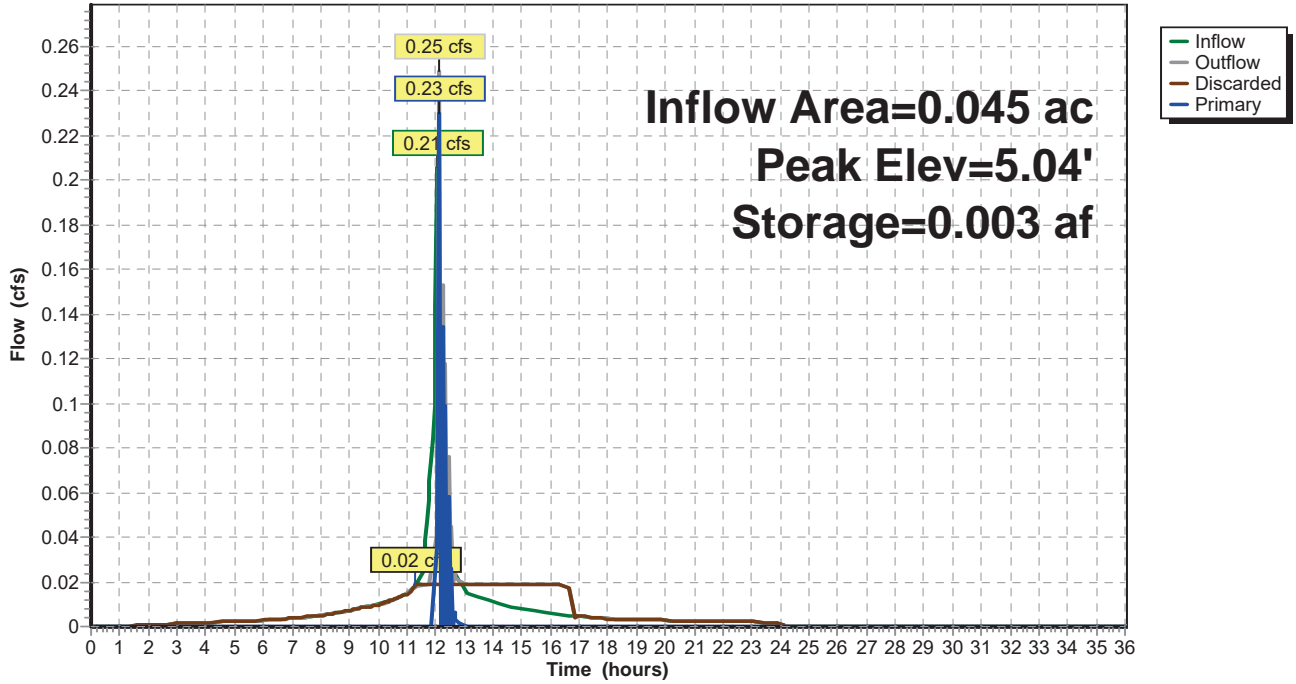
8.7 cy Field

6.4 cy Stone



Pond 14P: Infiltration

Hydrograph



# Mulberry Subdivision

Type III 24-hr 10-Year Rainfall=4.66"

Prepared by Hildenbrand Engineering, PLLC

Printed 5/1/2023

HydroCAD® 10.10-6a s/n 11988 © 2020 HydroCAD Software Solutions LLC

Page 46

## Summary for Pond 15P: Infiltration

Inflow Area = 0.045 ac, 100.00% Impervious, Inflow Depth = 4.42" for 10-Year event  
 Inflow = 0.21 cfs @ 12.07 hrs, Volume= 0.017 af  
 Outflow = 0.25 cfs @ 12.15 hrs, Volume= 0.017 af, Atten= 0%, Lag= 4.5 min  
 Discarded = 0.02 cfs @ 11.30 hrs, Volume= 0.014 af  
 Primary = 0.23 cfs @ 12.15 hrs, Volume= 0.003 af  
 Routed to Reach 18R : DESIGN LINE

Routing by Stor-Ind method, Time Span= 0.00-36.00 hrs, dt= 0.05 hrs  
 Peak Elev= 5.04' @ 12.15 hrs Surf.Area= 0.002 ac Storage= 0.003 af

Plug-Flow detention time= 37.1 min calculated for 0.017 af (100% of inflow)  
 Center-of-Mass det. time= 37.0 min ( 785.3 - 748.3 )

Volume	Invert	Avail.Storage	Storage Description
#1A	0.00'	0.002 af	<b>6.33'W x 10.50'L x 3.54'H Field A</b> 0.005 af Overall - 0.001 af Embedded = 0.004 af x 40.0% Voids
#2A	0.50'	0.001 af	<b>Cultec R-330XLHD Inside #1</b> Effective Size= 47.8"W x 30.0"H => 7.45 sf x 7.00'L = 52.2 cf Overall Size= 52.0"W x 30.5"H x 8.50'L with 1.50' Overlap Row Length Adjustment= +1.50' x 7.45 sf x 1 rows
		0.003 af	Total Available Storage

Storage Group A created with Chamber Wizard

Device	Routing	Invert	Outlet Devices
#1	Discarded	0.00'	<b>12.000 in/hr Exfiltration over Surface area</b>
#2	Primary	5.00'	<b>24.0" x 24.0" Horiz. Orifice/Grate</b> C= 0.600 Limited to weir flow at low heads

**Discarded OutFlow** Max=0.02 cfs @ 11.30 hrs HW=0.05' (Free Discharge)  
 ↑**1=Exfiltration** (Exfiltration Controls 0.02 cfs)

**Primary OutFlow** Max=0.18 cfs @ 12.15 hrs HW=5.04' (Free Discharge)  
 ↑**2=Orifice/Grate** (Weir Controls 0.18 cfs @ 0.63 fps)

## Mulberry Subdivision

Prepared by Hildenbrand Engineering, PLLC

HydroCAD® 10.10-6a s/n 11988 © 2020 HydroCAD Software Solutions LLC

Type III 24-hr 10-Year Rainfall=4.66"

Printed 5/1/2023

Page 47

### Pond 15P: Infiltration - Chamber Wizard Field A

#### Chamber Model = Cultec R-330XLHD (Cultec Recharger® 330XLHD)

Effective Size= 47.8"W x 30.0"H => 7.45 sf x 7.00'L = 52.2 cf

Overall Size= 52.0"W x 30.5"H x 8.50'L with 1.50' Overlap

Row Length Adjustment= +1.50' x 7.45 sf x 1 rows

1 Chambers/Row x 7.00' Long +1.50' Row Adjustment = 8.50' Row Length +12.0" End Stone x 2 = 10.50' Base Length

1 Rows x 52.0" Wide + 12.0" Side Stone x 2 = 6.33' Base Width

6.0" Stone Base + 30.5" Chamber Height + 6.0" Stone Cover = 3.54' Field Height

1 Chambers x 52.2 cf +1.50' Row Adjustment x 7.45 sf x 1 Rows = 63.3 cf Chamber Storage

235.5 cf Field - 63.3 cf Chambers = 172.2 cf Stone x 40.0% Voids = 68.9 cf Stone Storage

Chamber Storage + Stone Storage = 132.2 cf = 0.003 af

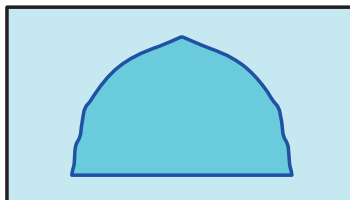
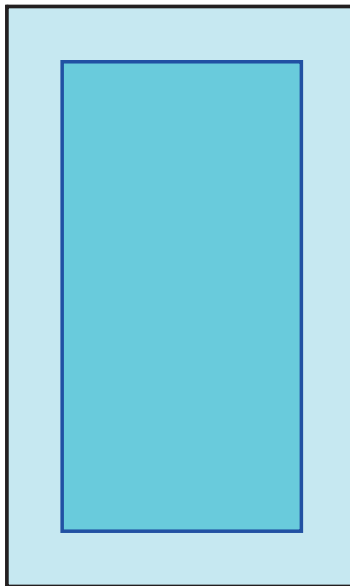
Overall Storage Efficiency = 56.1%

Overall System Size = 10.50' x 6.33' x 3.54'

1 Chambers

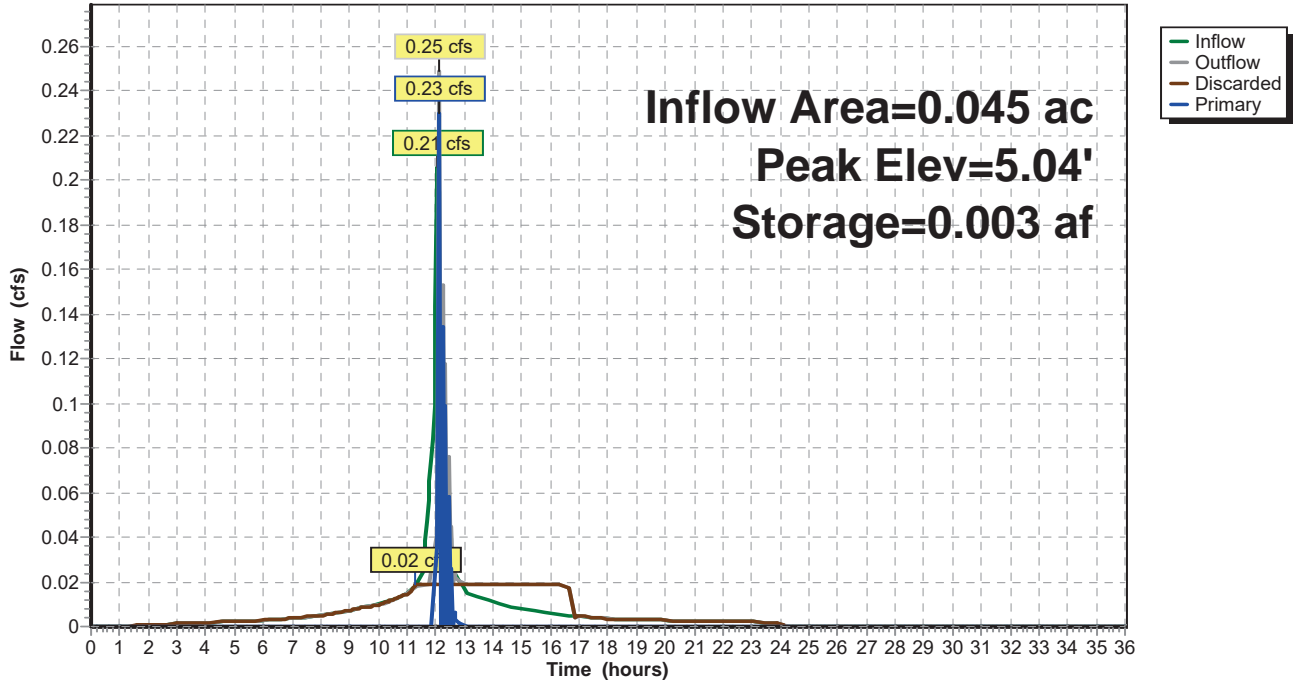
8.7 cy Field

6.4 cy Stone



Pond 15P: Infiltration

Hydrograph



# Mulberry Subdivision

Prepared by Hildenbrand Engineering, PLLC

HydroCAD® 10.10-6a s/n 11988 © 2020 HydroCAD Software Solutions LLC

Type III 24-hr 10-Year Rainfall=4.66"

Printed 5/1/2023

Page 49

## Summary for Pond 16P: Infiltration

Inflow Area = 0.045 ac, 100.00% Impervious, Inflow Depth = 4.42" for 10-Year event  
 Inflow = 0.20 cfs @ 12.07 hrs, Volume= 0.016 af  
 Outflow = 0.26 cfs @ 12.15 hrs, Volume= 0.016 af, Atten= 0%, Lag= 4.6 min  
 Discarded = 0.02 cfs @ 11.30 hrs, Volume= 0.014 af  
 Primary = 0.24 cfs @ 12.15 hrs, Volume= 0.003 af  
 Routed to Reach 18R : DESIGN LINE

Routing by Stor-Ind method, Time Span= 0.00-36.00 hrs, dt= 0.05 hrs  
 Peak Elev= 5.04' @ 12.15 hrs Surf.Area= 0.002 ac Storage= 0.003 af

Plug-Flow detention time= 37.1 min calculated for 0.016 af (100% of inflow)  
 Center-of-Mass det. time= 37.1 min ( 785.4 - 748.3 )

Volume	Invert	Avail.Storage	Storage Description
#1A	0.00'	0.002 af	<b>6.33'W x 10.50'L x 3.54'H Field A</b> 0.005 af Overall - 0.001 af Embedded = 0.004 af x 40.0% Voids
#2A	0.50'	0.001 af	<b>Cultec R-330XLHD Inside #1</b> Effective Size= 47.8"W x 30.0"H => 7.45 sf x 7.00'L = 52.2 cf Overall Size= 52.0"W x 30.5"H x 8.50'L with 1.50' Overlap Row Length Adjustment= +1.50' x 7.45 sf x 1 rows
		0.003 af	Total Available Storage

Storage Group A created with Chamber Wizard

Device	Routing	Invert	Outlet Devices
#1	Discarded	0.00'	<b>12.000 in/hr Exfiltration over Surface area</b>
#2	Primary	5.00'	<b>24.0" x 24.0" Horiz. Orifice/Grate</b> C= 0.600 Limited to weir flow at low heads

**Discarded OutFlow** Max=0.02 cfs @ 11.30 hrs HW=0.05' (Free Discharge)  
 ↑1=Exfiltration (Exfiltration Controls 0.02 cfs)

**Primary OutFlow** Max=0.20 cfs @ 12.15 hrs HW=5.04' (Free Discharge)  
 ↑2=Orifice/Grate (Weir Controls 0.20 cfs @ 0.64 fps)

## Mulberry Subdivision

Prepared by Hildenbrand Engineering, PLLC

HydroCAD® 10.10-6a s/n 11988 © 2020 HydroCAD Software Solutions LLC

Type III 24-hr 10-Year Rainfall=4.66"

Printed 5/1/2023

Page 50

### Pond 16P: Infiltration - Chamber Wizard Field A

#### Chamber Model = Cultec R-330XLHD (Cultec Recharger® 330XLHD)

Effective Size= 47.8"W x 30.0"H => 7.45 sf x 7.00'L = 52.2 cf

Overall Size= 52.0"W x 30.5"H x 8.50'L with 1.50' Overlap

Row Length Adjustment= +1.50' x 7.45 sf x 1 rows

1 Chambers/Row x 7.00' Long +1.50' Row Adjustment = 8.50' Row Length +12.0" End Stone x 2 = 10.50' Base Length

1 Rows x 52.0" Wide + 12.0" Side Stone x 2 = 6.33' Base Width

6.0" Stone Base + 30.5" Chamber Height + 6.0" Stone Cover = 3.54' Field Height

1 Chambers x 52.2 cf +1.50' Row Adjustment x 7.45 sf x 1 Rows = 63.3 cf Chamber Storage

235.5 cf Field - 63.3 cf Chambers = 172.2 cf Stone x 40.0% Voids = 68.9 cf Stone Storage

Chamber Storage + Stone Storage = 132.2 cf = 0.003 af

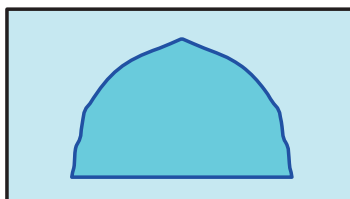
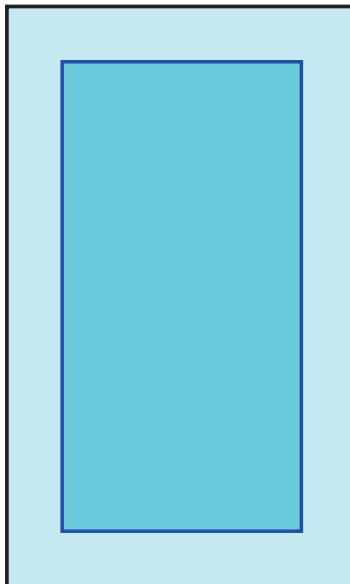
Overall Storage Efficiency = 56.1%

Overall System Size = 10.50' x 6.33' x 3.54'

1 Chambers

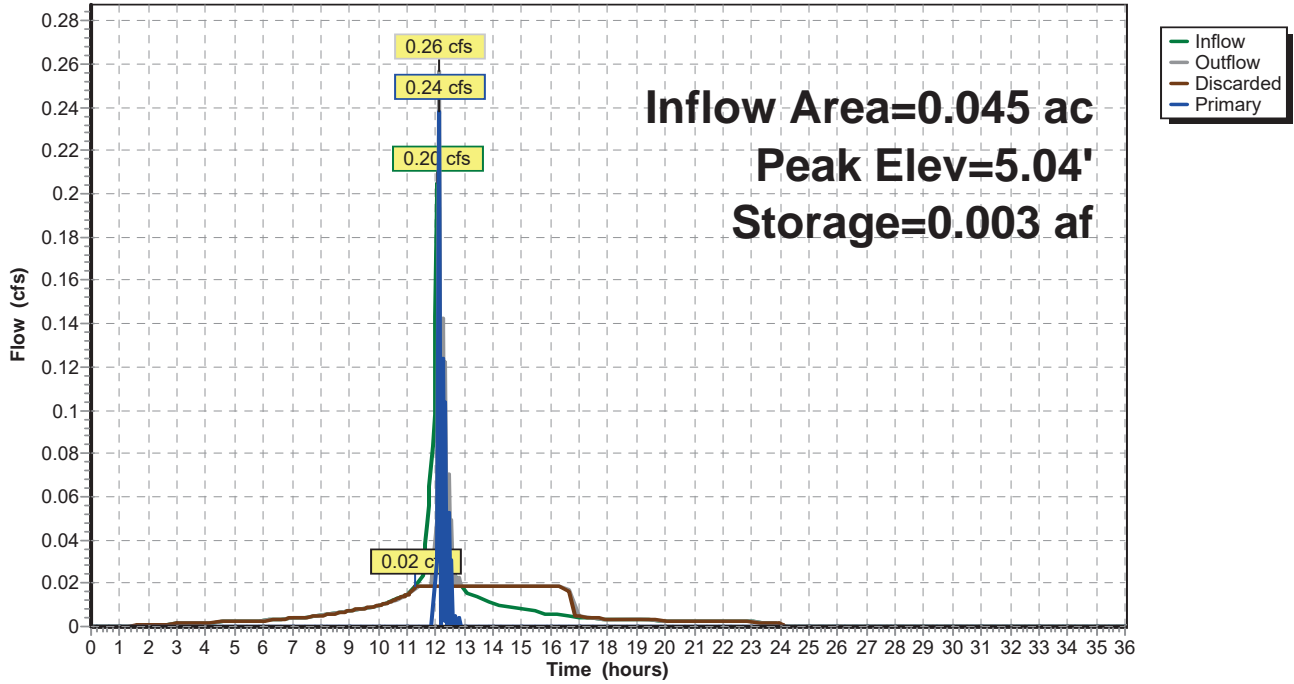
8.7 cy Field

6.4 cy Stone



Pond 16P: Infiltration

Hydrograph





# Mulberry Subdivision

Prepared by Hildenbrand Engineering, PLLC

HydroCAD® 10.10-6a s/n 11988 © 2020 HydroCAD Software Solutions LLC

Type III 24-hr 10-Year Rainfall=4.66"

Printed 5/1/2023

Page 52

## Summary for Pond 17P: Infiltration

Inflow Area = 0.182 ac, 100.00% Impervious, Inflow Depth = 4.42" for 10-Year event  
 Inflow = 0.83 cfs @ 12.07 hrs, Volume= 0.067 af  
 Outflow = 0.17 cfs @ 11.70 hrs, Volume= 0.067 af, Atten= 79%, Lag= 0.0 min  
 Discarded = 0.17 cfs @ 11.70 hrs, Volume= 0.067 af  
 Primary = 0.00 cfs @ 0.00 hrs, Volume= 0.000 af  
 Routed to Reach 18R : DESIGN LINE

Routing by Stor-Ind method, Time Span= 0.00-36.00 hrs, dt= 0.05 hrs  
 Peak Elev= 1.56' @ 12.48 hrs Surf.Area= 0.014 ac Storage= 0.015 af

Plug-Flow detention time= 18.7 min calculated for 0.067 af (100% of inflow)  
 Center-of-Mass det. time= 18.7 min ( 767.0 - 748.3 )

Volume	Invert	Avail.Storage	Storage Description
#1A	0.00'	0.013 af	<b>16.00'W x 38.50'L x 3.54'H Field A</b> 0.050 af Overall - 0.019 af Embedded = 0.031 af x 40.0% Voids
#2A	0.50'	0.019 af	<b>Cultec R-330XLHD x 15 Inside #1</b> Effective Size= 47.8"W x 30.0"H => 7.45 sf x 7.00'L = 52.2 cf Overall Size= 52.0"W x 30.5"H x 8.50'L with 1.50' Overlap Row Length Adjustment= +1.50' x 7.45 sf x 3 rows
		0.031 af	Total Available Storage

Storage Group A created with Chamber Wizard

Device	Routing	Invert	Outlet Devices
#1	Discarded	0.00'	<b>12.000 in/hr Exfiltration over Surface area</b>
#2	Primary	5.00'	<b>24.0" x 24.0" Horiz. Orifice/Grate</b> C= 0.600 Limited to weir flow at low heads

**Discarded OutFlow** Max=0.17 cfs @ 11.70 hrs HW=0.05' (Free Discharge)  
 ↑1=Exfiltration (Exfiltration Controls 0.17 cfs)

**Primary OutFlow** Max=0.00 cfs @ 0.00 hrs HW=0.00' (Free Discharge)  
 ↑2=Orifice/Grate ( Controls 0.00 cfs)

# Mulberry Subdivision

Prepared by Hildenbrand Engineering, PLLC

HydroCAD® 10.10-6a s/n 11988 © 2020 HydroCAD Software Solutions LLC

Type III 24-hr 10-Year Rainfall=4.66"

Printed 5/1/2023

Page 53

## Pond 17P: Infiltration - Chamber Wizard Field A

### Chamber Model = Cultec R-330XLHD (Cultec Recharger® 330XLHD)

Effective Size= 47.8"W x 30.0"H => 7.45 sf x 7.00'L = 52.2 cf

Overall Size= 52.0"W x 30.5"H x 8.50'L with 1.50' Overlap

Row Length Adjustment= +1.50' x 7.45 sf x 3 rows

52.0" Wide + 6.0" Spacing = 58.0" C-C Row Spacing

5 Chambers/Row x 7.00' Long +1.50' Row Adjustment = 36.50' Row Length +12.0" End Stone x 2 = 38.50' Base Length

3 Rows x 52.0" Wide + 6.0" Spacing x 2 + 12.0" Side Stone x 2 = 16.00' Base Width

6.0" Stone Base + 30.5" Chamber Height + 6.0" Stone Cover = 3.54' Field Height

15 Chambers x 52.2 cf +1.50' Row Adjustment x 7.45 sf x 3 Rows = 815.9 cf Chamber Storage

2,181.7 cf Field - 815.9 cf Chambers = 1,365.8 cf Stone x 40.0% Voids = 546.3 cf Stone Storage

Chamber Storage + Stone Storage = 1,362.2 cf = 0.031 af

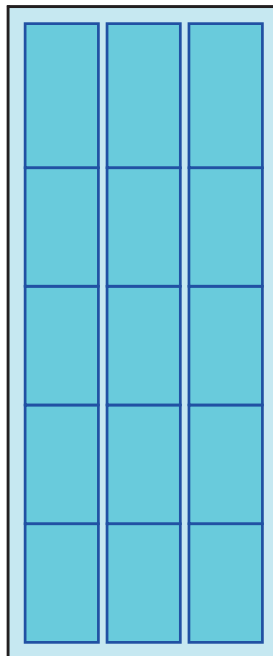
Overall Storage Efficiency = 62.4%

Overall System Size = 38.50' x 16.00' x 3.54'

15 Chambers

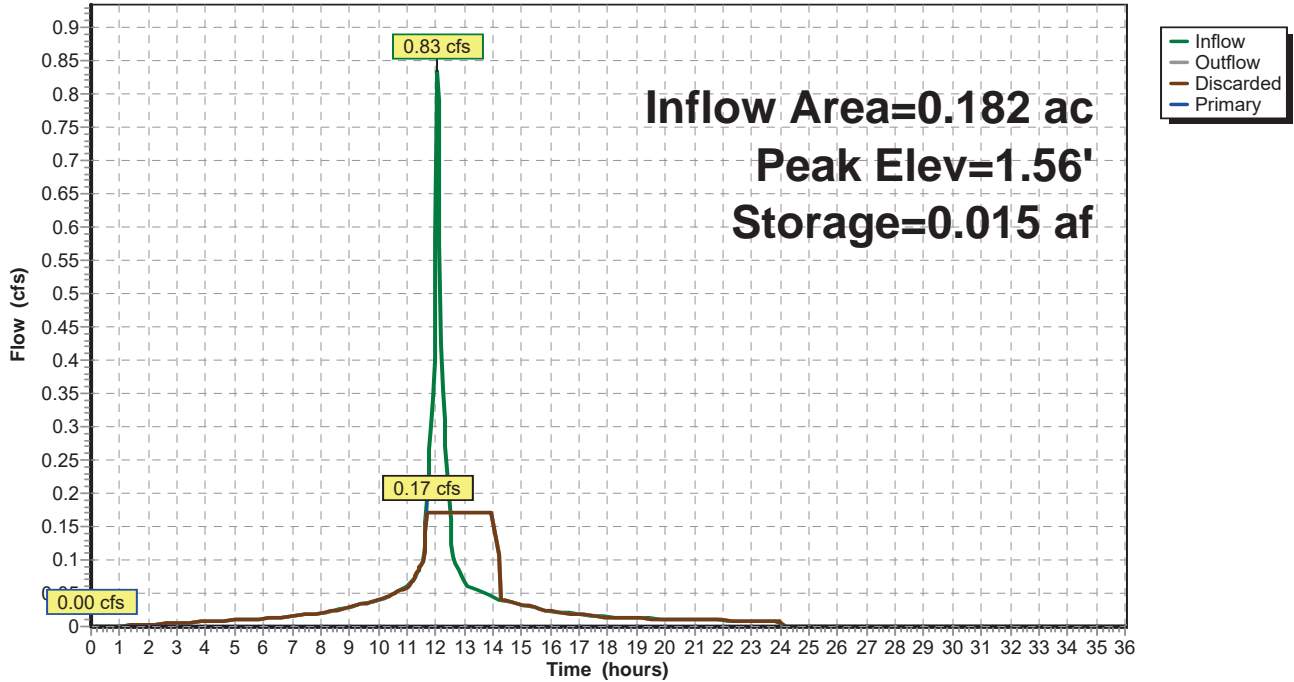
80.8 cy Field

50.6 cy Stone



Pond 17P: Infiltration

Hydrograph



# Mulberry Subdivision

Prepared by Hildenbrand Engineering, PLLC

HydroCAD® 10.10-6a s/n 11988 © 2020 HydroCAD Software Solutions LLC

Type III 24-hr 100-Year Rainfall=8.26"

Printed 5/1/2023

Page 55

## Summary for Subcatchment 2S: Lot #1 Remainder

Runoff = 0.70 cfs @ 12.08 hrs, Volume= 0.050 af, Depth= 4.22"  
 Routed to Reach 18R : DESIGN LINE

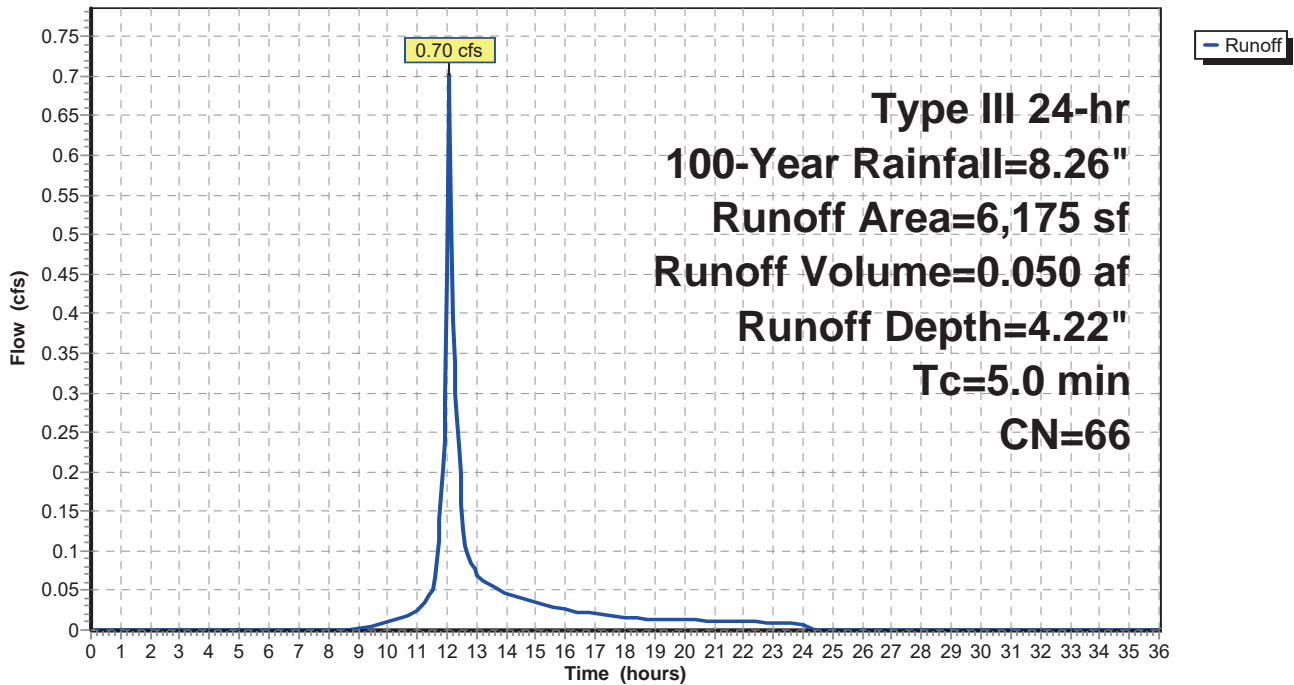
Runoff by SCS TR-20 method, UH=SCS, Weighted-CN, Time Span= 0.00-36.00 hrs, dt= 0.05 hrs  
 Type III 24-hr 100-Year Rainfall=8.26"

	Area (sf)	CN	Description
*	815	98	Driveway
	5,360	61	>75% Grass cover, Good, HSG B
	6,175	66	Weighted Average
	5,360		86.80% Pervious Area
	815		13.20% Impervious Area

Tc (min)	Length (feet)	Slope (ft/ft)	Velocity (ft/sec)	Capacity (cfs)	Description
5.0					Direct Entry,

## Subcatchment 2S: Lot #1 Remainder

Hydrograph



# Mulberry Subdivision

Prepared by Hildenbrand Engineering, PLLC

HydroCAD® 10.10-6a s/n 11988 © 2020 HydroCAD Software Solutions LLC

Type III 24-hr 100-Year Rainfall=8.26"

Printed 5/1/2023

Page 56

## Summary for Subcatchment 3S: Lot #2 Remainder

Runoff = 0.71 cfs @ 12.08 hrs, Volume= 0.050 af, Depth= 4.22"  
Routed to Reach 18R : DESIGN LINE

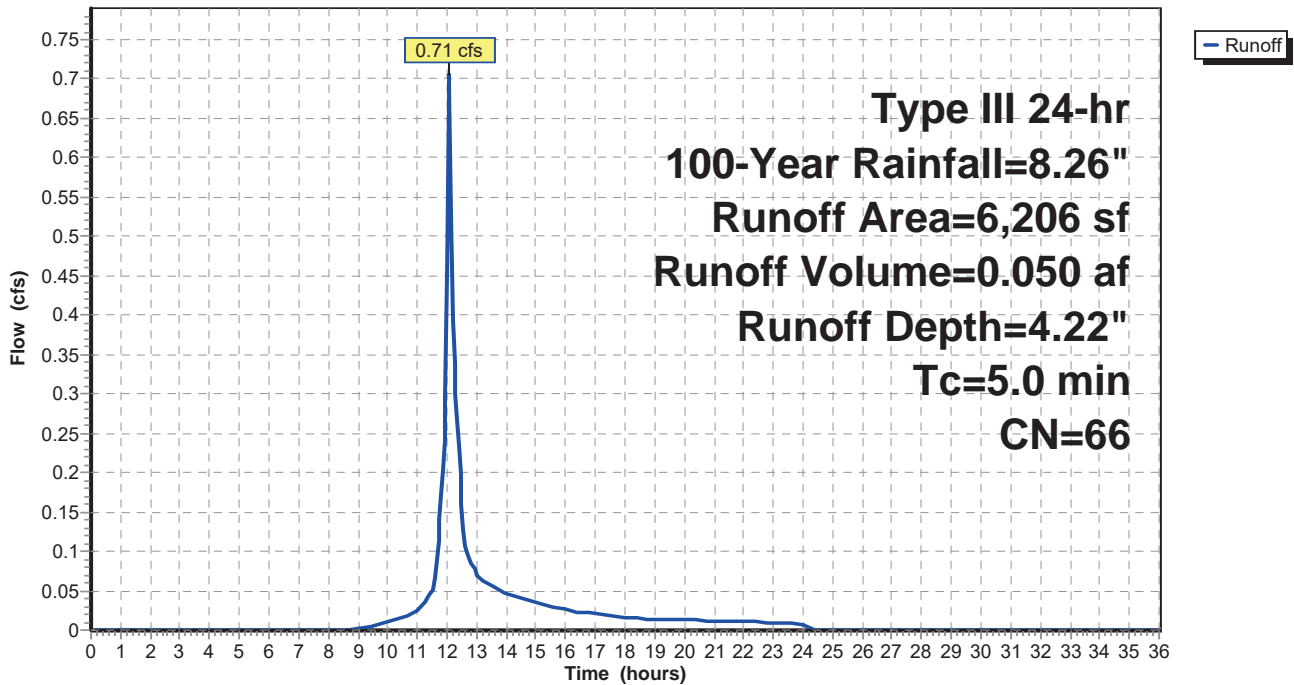
Runoff by SCS TR-20 method, UH=SCS, Weighted-CN, Time Span= 0.00-36.00 hrs, dt= 0.05 hrs  
Type III 24-hr 100-Year Rainfall=8.26"

	Area (sf)	CN	Description
*	815	98	Driveway
	5,391	61	>75% Grass cover, Good, HSG B
	6,206	66	Weighted Average
	5,391		86.87% Pervious Area
	815		13.13% Impervious Area

Tc (min)	Length (feet)	Slope (ft/ft)	Velocity (ft/sec)	Capacity (cfs)	Description
5.0					Direct Entry,

## Subcatchment 3S: Lot #2 Remainder

Hydrograph



# Mulberry Subdivision

Prepared by Hildenbrand Engineering, PLLC

HydroCAD® 10.10-6a s/n 11988 © 2020 HydroCAD Software Solutions LLC

Type III 24-hr 100-Year Rainfall=8.26"

Printed 5/1/2023

Page 57

## Summary for Subcatchment 4S: Lot #3 Remainder

Runoff = 2.98 cfs @ 12.08 hrs, Volume= 0.213 af, Depth= 5.16"  
 Routed to Reach 18R : DESIGN LINE

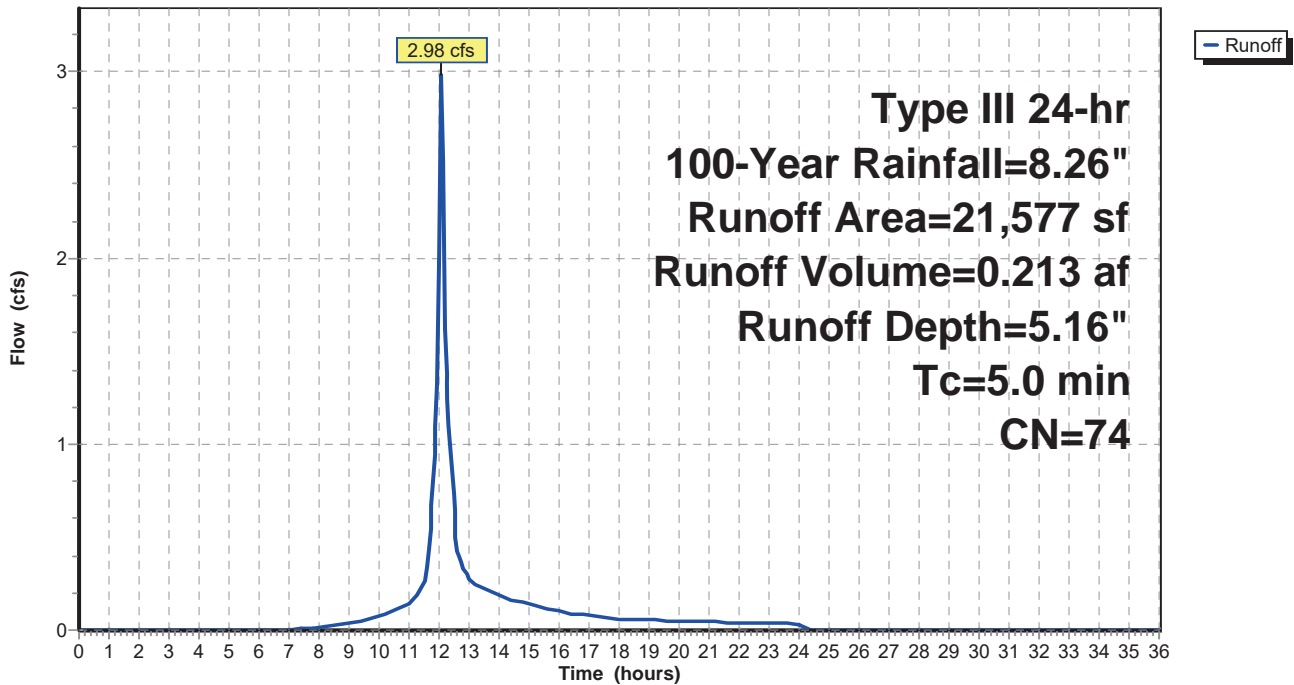
Runoff by SCS TR-20 method, UH=SCS, Weighted-CN, Time Span= 0.00-36.00 hrs, dt= 0.05 hrs  
 Type III 24-hr 100-Year Rainfall=8.26"

	Area (sf)	CN	Description
*	7,583	98	Driveway
	13,994	61	>75% Grass cover, Good, HSG B
	21,577	74	Weighted Average
	13,994		64.86% Pervious Area
	7,583		35.14% Impervious Area

Tc (min)	Length (feet)	Slope (ft/ft)	Velocity (ft/sec)	Capacity (cfs)	Description
5.0					Direct Entry,

## Subcatchment 4S: Lot #3 Remainder

Hydrograph



# Mulberry Subdivision

Prepared by Hildenbrand Engineering, PLLC

HydroCAD® 10.10-6a s/n 11988 © 2020 HydroCAD Software Solutions LLC

Type III 24-hr 100-Year Rainfall=8.26"

Printed 5/1/2023

Page 58

## Summary for Subcatchment 5S: Lot #4 Remainder

Runoff = 0.73 cfs @ 12.08 hrs, Volume= 0.052 af, Depth= 4.11"  
 Routed to Reach 18R : DESIGN LINE

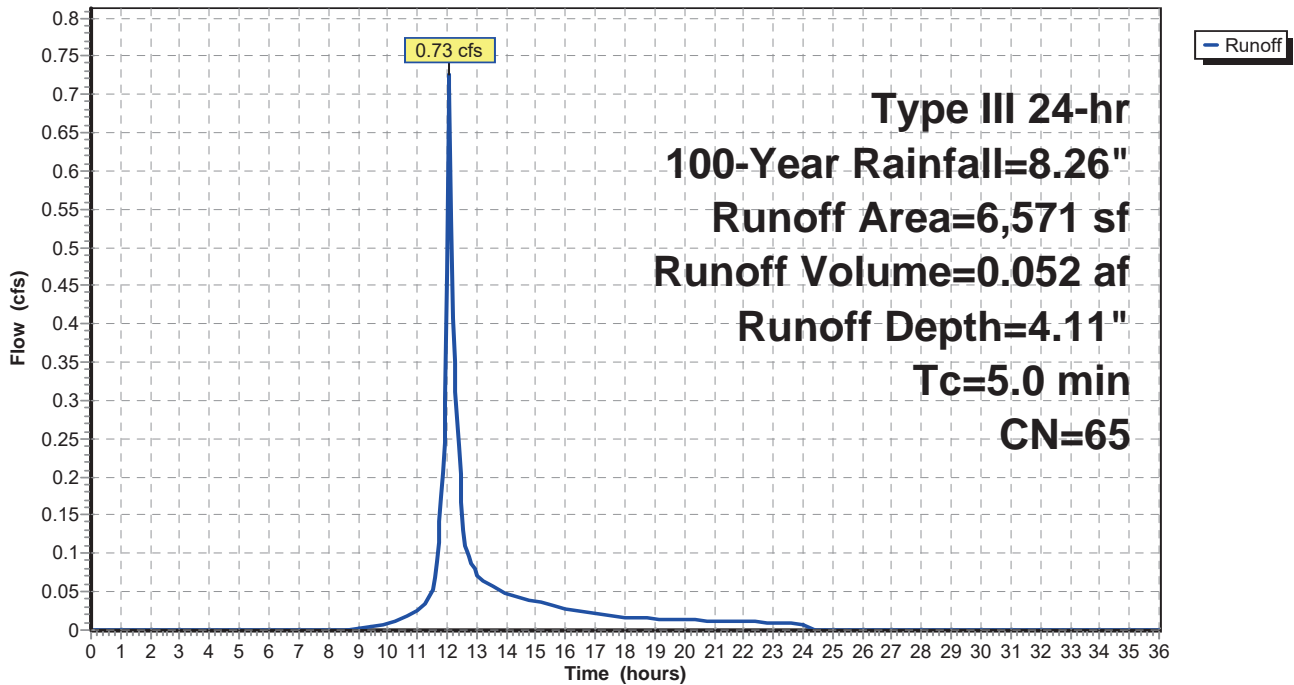
Runoff by SCS TR-20 method, UH=SCS, Weighted-CN, Time Span= 0.00-36.00 hrs, dt= 0.05 hrs  
 Type III 24-hr 100-Year Rainfall=8.26"

	Area (sf)	CN	Description
*	709	98	Driveway
	5,862	61	>75% Grass cover, Good, HSG B
	6,571	65	Weighted Average
	5,862		89.21% Pervious Area
	709		10.79% Impervious Area

Tc (min)	Length (feet)	Slope (ft/ft)	Velocity (ft/sec)	Capacity (cfs)	Description
5.0					Direct Entry,

## Subcatchment 5S: Lot #4 Remainder

Hydrograph



# Mulberry Subdivision

Prepared by Hildenbrand Engineering, PLLC

HydroCAD® 10.10-6a s/n 11988 © 2020 HydroCAD Software Solutions LLC

Type III 24-hr 100-Year Rainfall=8.26"

Printed 5/1/2023

Page 59

## Summary for Subcatchment 6S: Lot #5 Remainder

Runoff = 0.75 cfs @ 12.08 hrs, Volume= 0.053 af, Depth= 4.22"  
 Routed to Reach 18R : DESIGN LINE

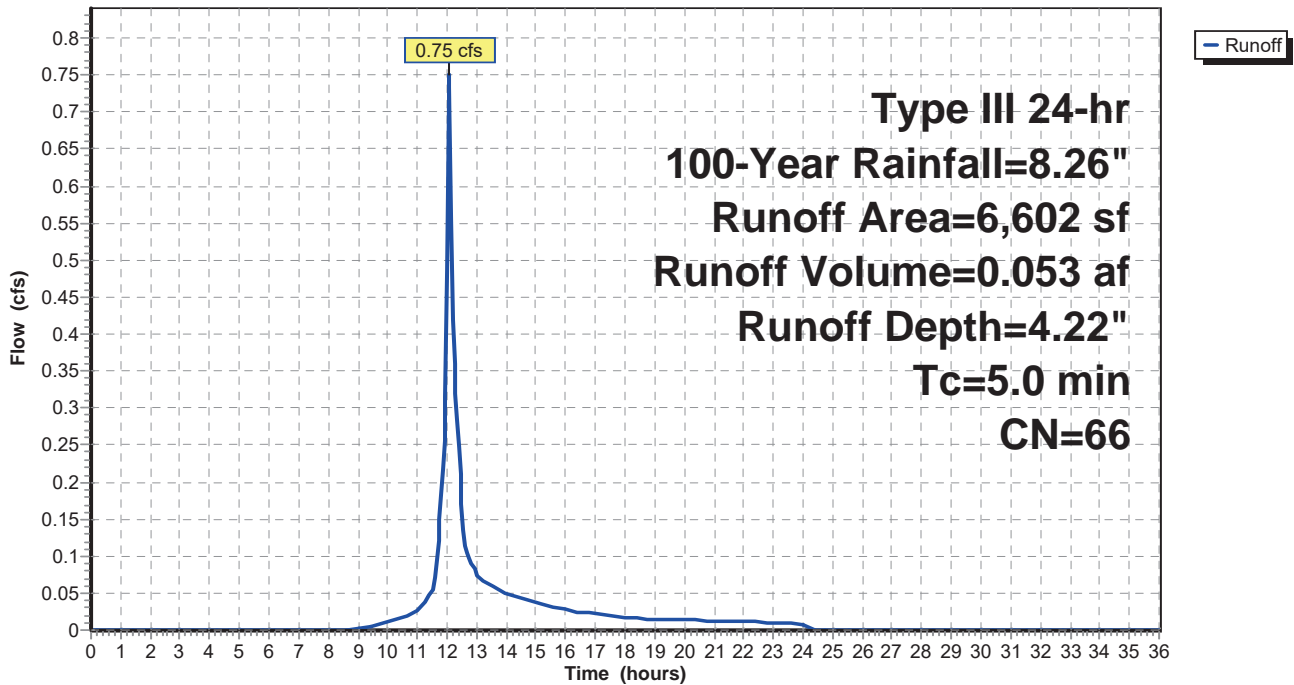
Runoff by SCS TR-20 method, UH=SCS, Weighted-CN, Time Span= 0.00-36.00 hrs, dt= 0.05 hrs  
 Type III 24-hr 100-Year Rainfall=8.26"

	Area (sf)	CN	Description
*	974	98	Driveway
	5,628	61	>75% Grass cover, Good, HSG B
	6,602	66	Weighted Average
	5,628		85.25% Pervious Area
	974		14.75% Impervious Area

Tc (min)	Length (feet)	Slope (ft/ft)	Velocity (ft/sec)	Capacity (cfs)	Description
5.0					Direct Entry,

## Subcatchment 6S: Lot #5 Remainder

Hydrograph





**Mulberry Subdivision**

Prepared by Hildenbrand Engineering, PLLC

HydroCAD® 10.10-6a s/n 11988 © 2020 HydroCAD Software Solutions LLC

Type III 24-hr 100-Year Rainfall=8.26"

Printed 5/1/2023

Page 60

**Summary for Subcatchment 8S: Lot #1 Roof**

Runoff = 0.37 cfs @ 12.07 hrs, Volume= 0.030 af, Depth= 8.02"  
 Routed to Pond 13P : Infiltration

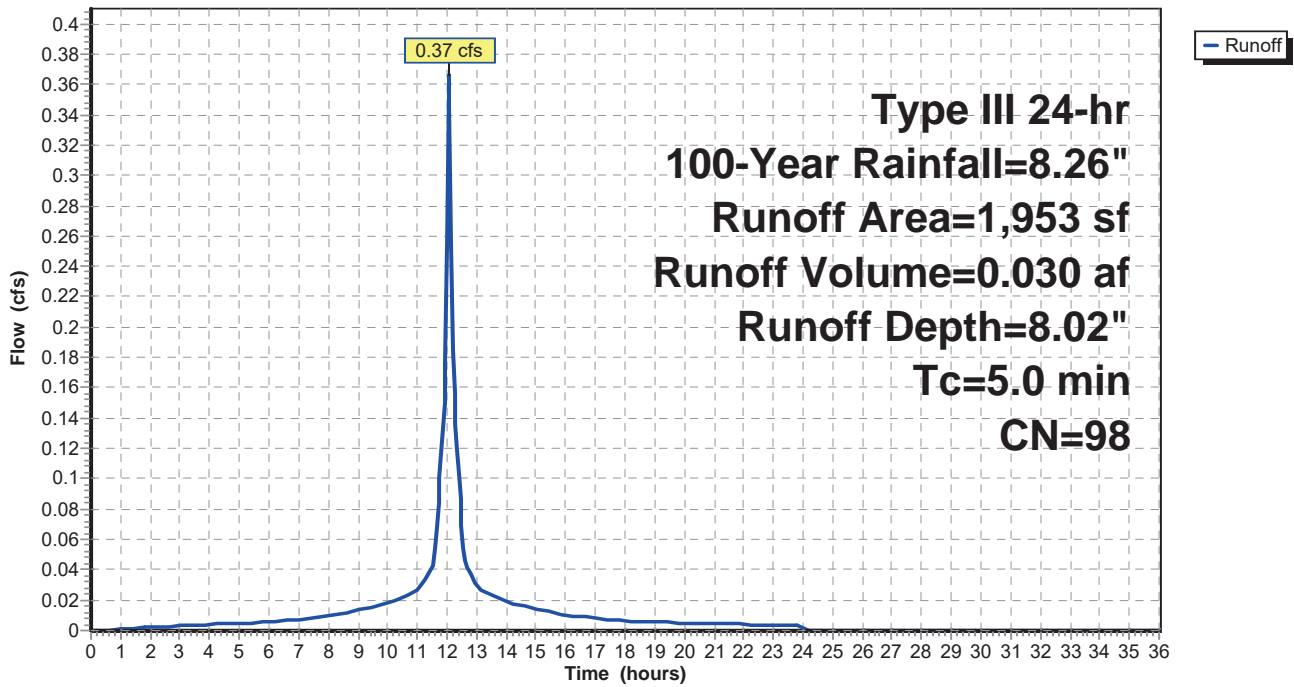
Runoff by SCS TR-20 method, UH=SCS, Weighted-CN, Time Span= 0.00-36.00 hrs, dt= 0.05 hrs  
 Type III 24-hr 100-Year Rainfall=8.26"

Area (sf)	CN	Description
* 1,953	98	Roof Area
1,953		100.00% Impervious Area

Tc (min)	Length (feet)	Slope (ft/ft)	Velocity (ft/sec)	Capacity (cfs)	Description
5.0					Direct Entry,

**Subcatchment 8S: Lot #1 Roof**

Hydrograph



**Mulberry Subdivision**

Prepared by Hildenbrand Engineering, PLLC

HydroCAD® 10.10-6a s/n 11988 © 2020 HydroCAD Software Solutions LLC

Type III 24-hr 100-Year Rainfall=8.26"

Printed 5/1/2023

Page 61

**Summary for Subcatchment 9S: Lot #2 Roof**

Runoff = 0.37 cfs @ 12.07 hrs, Volume= 0.030 af, Depth= 8.02"  
 Routed to Pond 14P : Infiltration

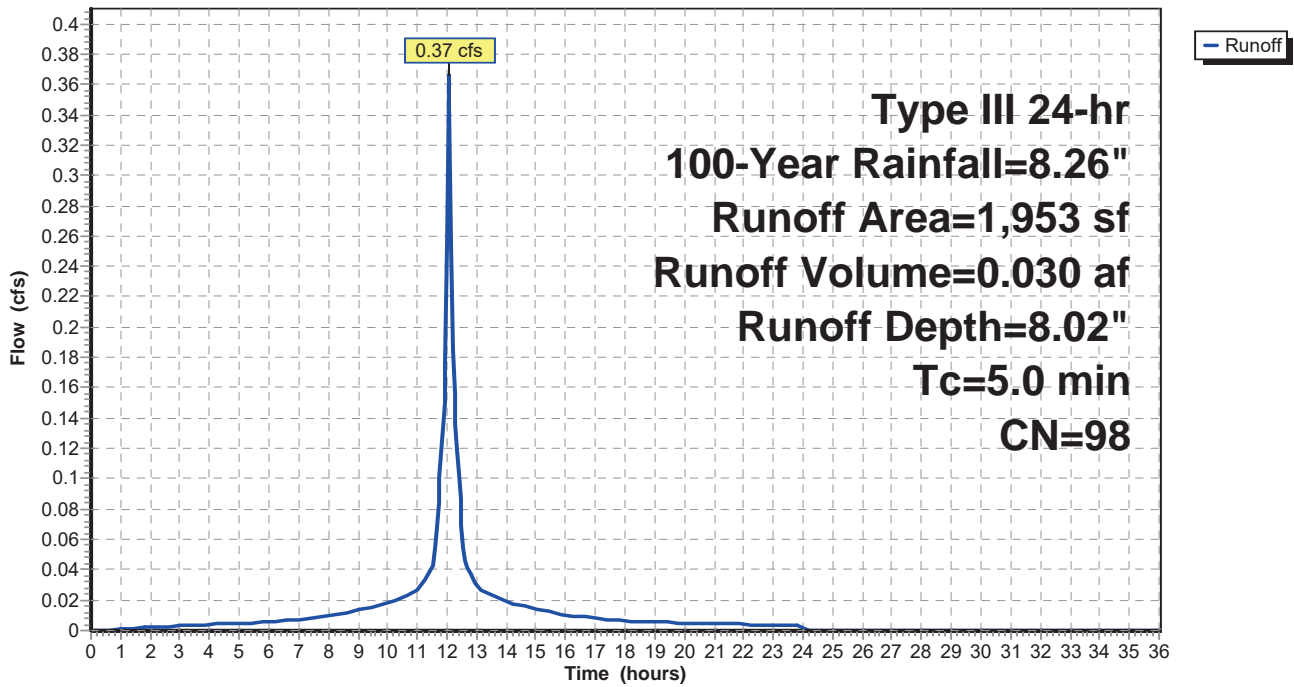
Runoff by SCS TR-20 method, UH=SCS, Weighted-CN, Time Span= 0.00-36.00 hrs, dt= 0.05 hrs  
 Type III 24-hr 100-Year Rainfall=8.26"

Area (sf)	CN	Description
* 1,953	98	Roof Area
1,953		100.00% Impervious Area

Tc (min)	Length (feet)	Slope (ft/ft)	Velocity (ft/sec)	Capacity (cfs)	Description
5.0					Direct Entry,

**Subcatchment 9S: Lot #2 Roof**

Hydrograph



# Mulberry Subdivision

Prepared by Hildenbrand Engineering, PLLC

HydroCAD® 10.10-6a s/n 11988 © 2020 HydroCAD Software Solutions LLC

Type III 24-hr 100-Year Rainfall=8.26"

Printed 5/1/2023

Page 62

## Summary for Subcatchment 10S: Lot #3 Roof

Runoff = 1.48 cfs @ 12.07 hrs, Volume= 0.122 af, Depth= 8.02"  
Routed to Pond 17P : Infiltration

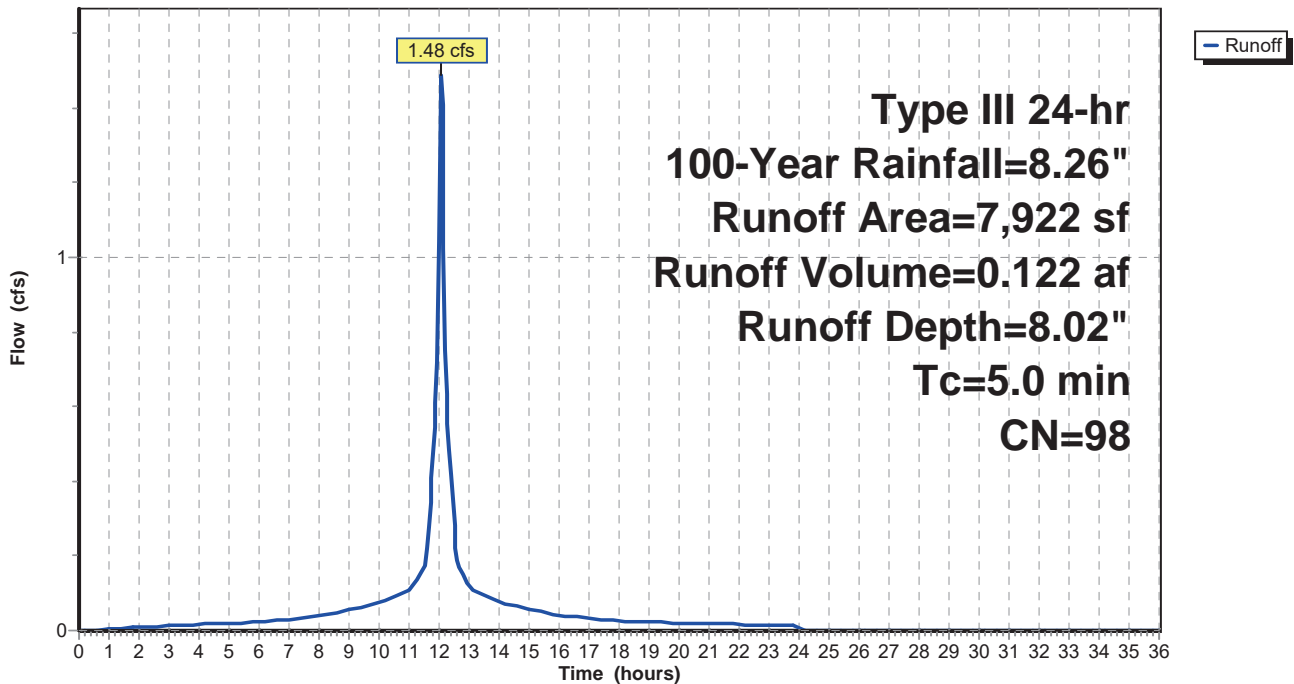
Runoff by SCS TR-20 method, UH=SCS, Weighted-CN, Time Span= 0.00-36.00 hrs, dt= 0.05 hrs  
Type III 24-hr 100-Year Rainfall=8.26"

Area (sf)	CN	Description
* 7,922	98	Roof Area
7,922		100.00% Impervious Area

Tc (min)	Length (feet)	Slope (ft/ft)	Velocity (ft/sec)	Capacity (cfs)	Description
5.0					Direct Entry,

## Subcatchment 10S: Lot #3 Roof

Hydrograph



**Mulberry Subdivision**

Prepared by Hildenbrand Engineering, PLLC

HydroCAD® 10.10-6a s/n 11988 © 2020 HydroCAD Software Solutions LLC

Type III 24-hr 100-Year Rainfall=8.26"

Printed 5/1/2023

Page 63

**Summary for Subcatchment 11S: Lot #4 Roof**

Runoff = 0.37 cfs @ 12.07 hrs, Volume= 0.030 af, Depth= 8.02"  
 Routed to Pond 15P : Infiltration

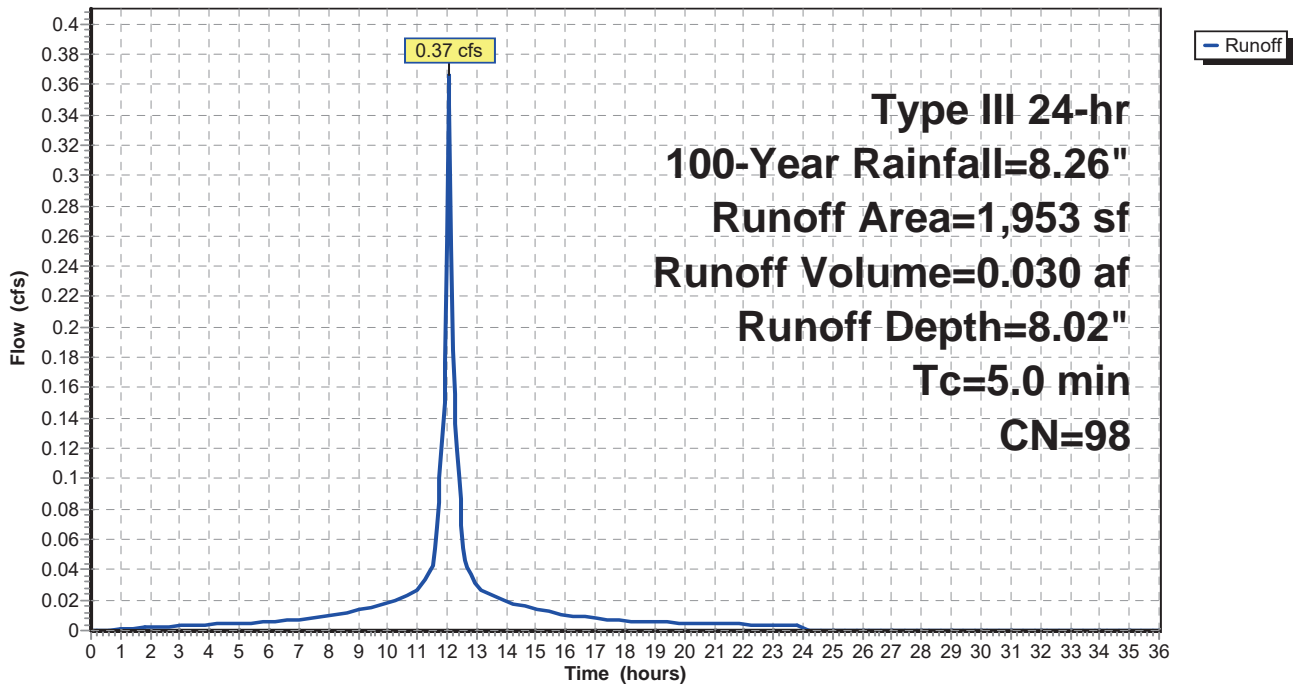
Runoff by SCS TR-20 method, UH=SCS, Weighted-CN, Time Span= 0.00-36.00 hrs, dt= 0.05 hrs  
 Type III 24-hr 100-Year Rainfall=8.26"

Area (sf)	CN	Description
* 1,953	98	Roof Area
1,953		100.00% Impervious Area

Tc (min)	Length (feet)	Slope (ft/ft)	Velocity (ft/sec)	Capacity (cfs)	Description
5.0					Direct Entry,

**Subcatchment 11S: Lot #4 Roof**

Hydrograph



**Mulberry Subdivision**

Prepared by Hildenbrand Engineering, PLLC

HydroCAD® 10.10-6a s/n 11988 © 2020 HydroCAD Software Solutions LLC

Type III 24-hr 100-Year Rainfall=8.26"

Printed 5/1/2023

Page 64

**Summary for Subcatchment 12S: Lot #5 Roof**

Runoff = 0.36 cfs @ 12.07 hrs, Volume= 0.030 af, Depth= 8.02"  
 Routed to Pond 16P : Infiltration

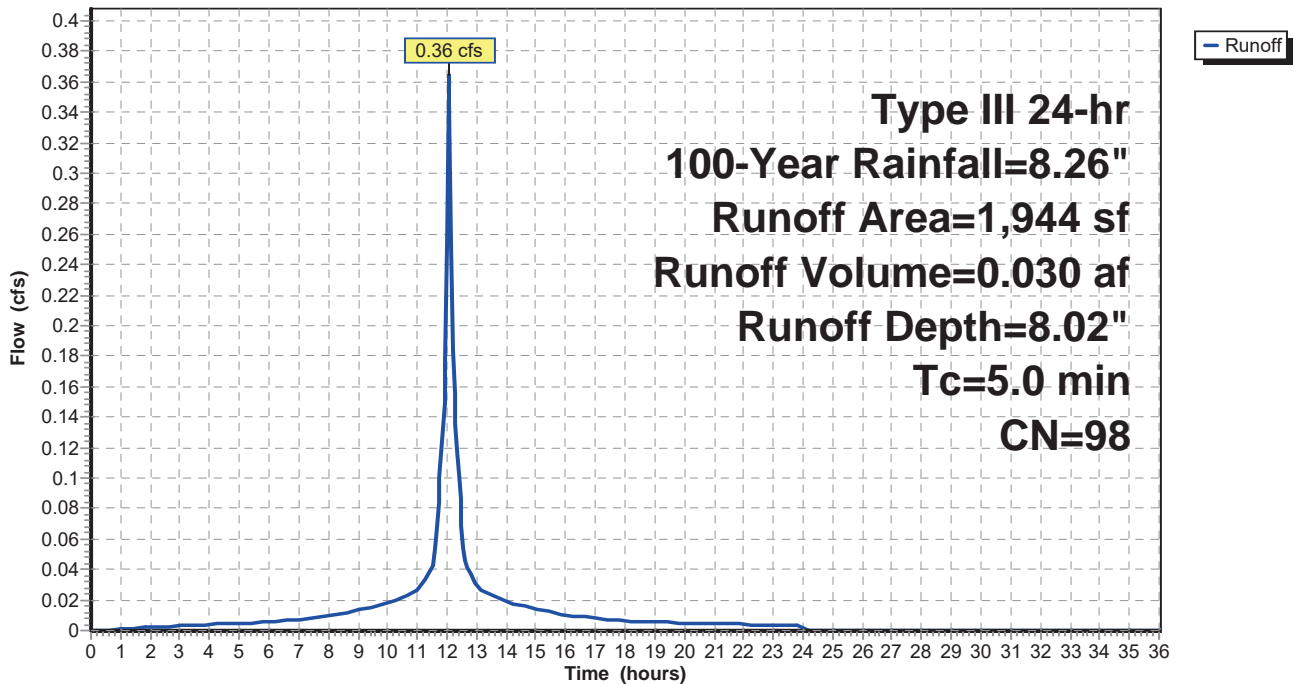
Runoff by SCS TR-20 method, UH=SCS, Weighted-CN, Time Span= 0.00-36.00 hrs, dt= 0.05 hrs  
 Type III 24-hr 100-Year Rainfall=8.26"

Area (sf)	CN	Description
* 1,944	98	Roof Area
1,944		100.00% Impervious Area

Tc (min)	Length (feet)	Slope (ft/ft)	Velocity (ft/sec)	Capacity (cfs)	Description
5.0					Direct Entry,

**Subcatchment 12S: Lot #5 Roof**

Hydrograph



# Mulberry Subdivision

Prepared by Hildenbrand Engineering, PLLC

HydroCAD® 10.10-6a s/n 11988 © 2020 HydroCAD Software Solutions LLC

Type III 24-hr 100-Year Rainfall=8.26"

Printed 5/1/2023

Page 65

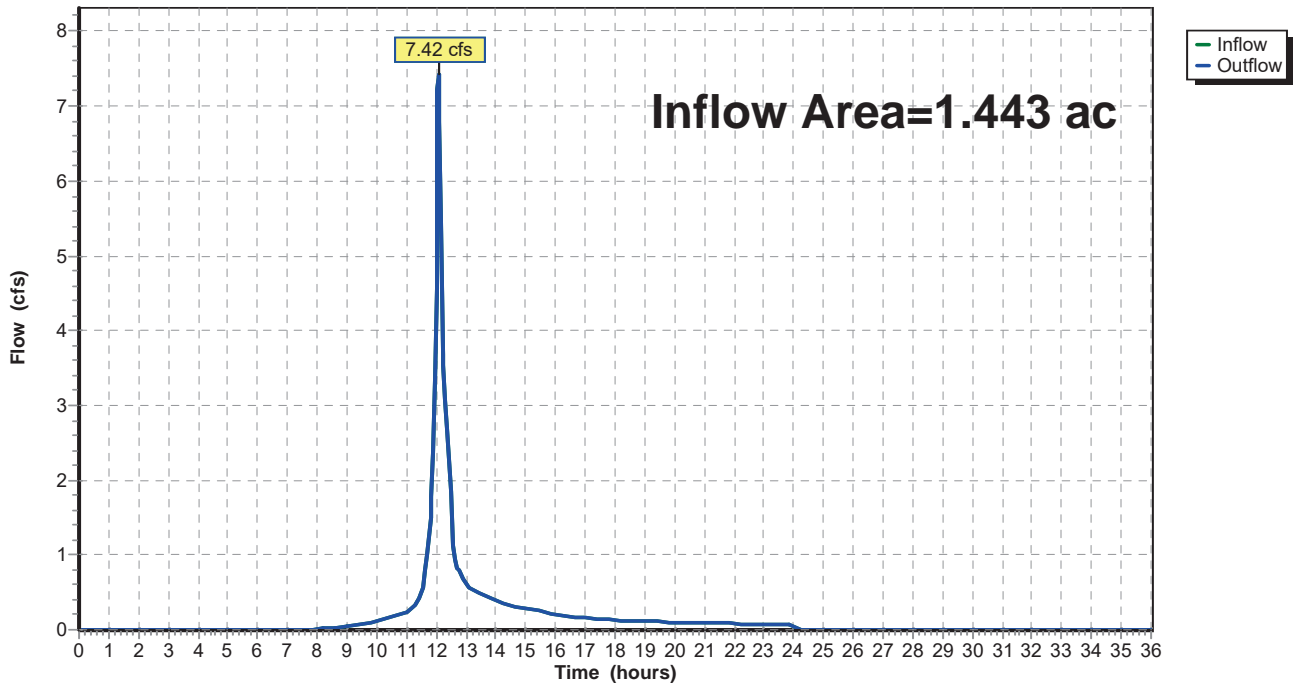
## Summary for Reach 18R: DESIGN LINE

Inflow Area = 1.443 ac, 42.35% Impervious, Inflow Depth = 3.85" for 100-Year event  
Inflow = 7.42 cfs @ 12.07 hrs, Volume= 0.463 af  
Outflow = 7.42 cfs @ 12.07 hrs, Volume= 0.463 af, Atten= 0%, Lag= 0.0 min

Routing by Stor-Ind+Trans method, Time Span= 0.00-36.00 hrs, dt= 0.05 hrs

## Reach 18R: DESIGN LINE

Hydrograph



# Mulberry Subdivision

Prepared by Hildenbrand Engineering, PLLC

HydroCAD® 10.10-6a s/n 11988 © 2020 HydroCAD Software Solutions LLC

Type III 24-hr 100-Year Rainfall=8.26"

Printed 5/1/2023

Page 66

## Summary for Pond 13P: Infiltration

Inflow Area = 0.045 ac, 100.00% Impervious, Inflow Depth = 8.02" for 100-Year event  
 Inflow = 0.37 cfs @ 12.07 hrs, Volume= 0.030 af  
 Outflow = 0.41 cfs @ 12.06 hrs, Volume= 0.030 af, Atten= 0%, Lag= 0.0 min  
 Discarded = 0.02 cfs @ 10.15 hrs, Volume= 0.020 af  
 Primary = 0.40 cfs @ 12.06 hrs, Volume= 0.010 af  
 Routed to Reach 18R : DESIGN LINE

Routing by Stor-Ind method, Time Span= 0.00-36.00 hrs, dt= 0.05 hrs  
 Peak Elev= 5.06' @ 12.06 hrs Surf.Area= 0.002 ac Storage= 0.003 af

Plug-Flow detention time= 33.0 min calculated for 0.030 af (100% of inflow)  
 Center-of-Mass det. time= 33.0 min ( 772.9 - 739.9 )

Volume	Invert	Avail.Storage	Storage Description
#1A	0.00'	0.002 af	<b>6.33'W x 10.50'L x 3.54'H Field A</b> 0.005 af Overall - 0.001 af Embedded = 0.004 af x 40.0% Voids
#2A	0.50'	0.001 af	<b>Cultec R-330XLHD Inside #1</b> Effective Size= 47.8"W x 30.0"H => 7.45 sf x 7.00'L = 52.2 cf Overall Size= 52.0"W x 30.5"H x 8.50'L with 1.50' Overlap Row Length Adjustment= +1.50' x 7.45 sf x 1 rows
		0.003 af	Total Available Storage

Storage Group A created with Chamber Wizard

Device	Routing	Invert	Outlet Devices
#1	Discarded	0.00'	<b>12.000 in/hr Exfiltration over Surface area</b>
#2	Primary	5.00'	<b>24.0" x 24.0" Horiz. Orifice/Grate</b> C= 0.600 Limited to weir flow at low heads

**Discarded OutFlow** Max=0.02 cfs @ 10.15 hrs HW=0.05' (Free Discharge)  
 ↑**1=Exfiltration** (Exfiltration Controls 0.02 cfs)

**Primary OutFlow** Max=0.36 cfs @ 12.06 hrs HW=5.06' (Free Discharge)  
 ↑**2=Orifice/Grate** (Weir Controls 0.36 cfs @ 0.78 fps)

**Mulberry Subdivision**

Prepared by Hildenbrand Engineering, PLLC

HydroCAD® 10.10-6a s/n 11988 © 2020 HydroCAD Software Solutions LLC

Type III 24-hr 100-Year Rainfall=8.26"

Printed 5/1/2023

Page 67

**Pond 13P: Infiltration - Chamber Wizard Field A**

**Chamber Model = Cultec R-330XLHD (Cultec Recharger® 330XLHD)**

Effective Size= 47.8"W x 30.0"H => 7.45 sf x 7.00'L = 52.2 cf

Overall Size= 52.0"W x 30.5"H x 8.50'L with 1.50' Overlap

Row Length Adjustment= +1.50' x 7.45 sf x 1 rows

1 Chambers/Row x 7.00' Long +1.50' Row Adjustment = 8.50' Row Length +12.0" End Stone x 2 = 10.50' Base Length

1 Rows x 52.0" Wide + 12.0" Side Stone x 2 = 6.33' Base Width

6.0" Stone Base + 30.5" Chamber Height + 6.0" Stone Cover = 3.54' Field Height

1 Chambers x 52.2 cf +1.50' Row Adjustment x 7.45 sf x 1 Rows = 63.3 cf Chamber Storage

235.5 cf Field - 63.3 cf Chambers = 172.2 cf Stone x 40.0% Voids = 68.9 cf Stone Storage

Chamber Storage + Stone Storage = 132.2 cf = 0.003 af

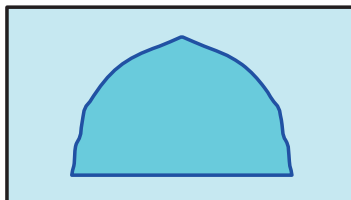
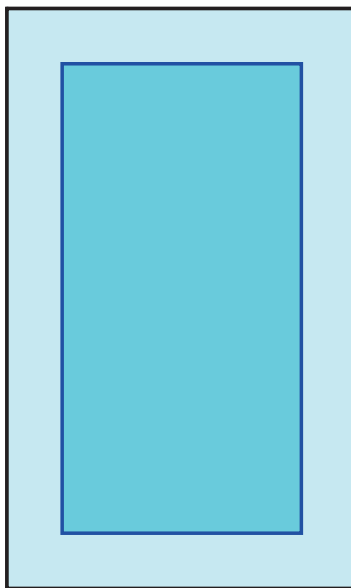
Overall Storage Efficiency = 56.1%

Overall System Size = 10.50' x 6.33' x 3.54'

1 Chambers

8.7 cy Field

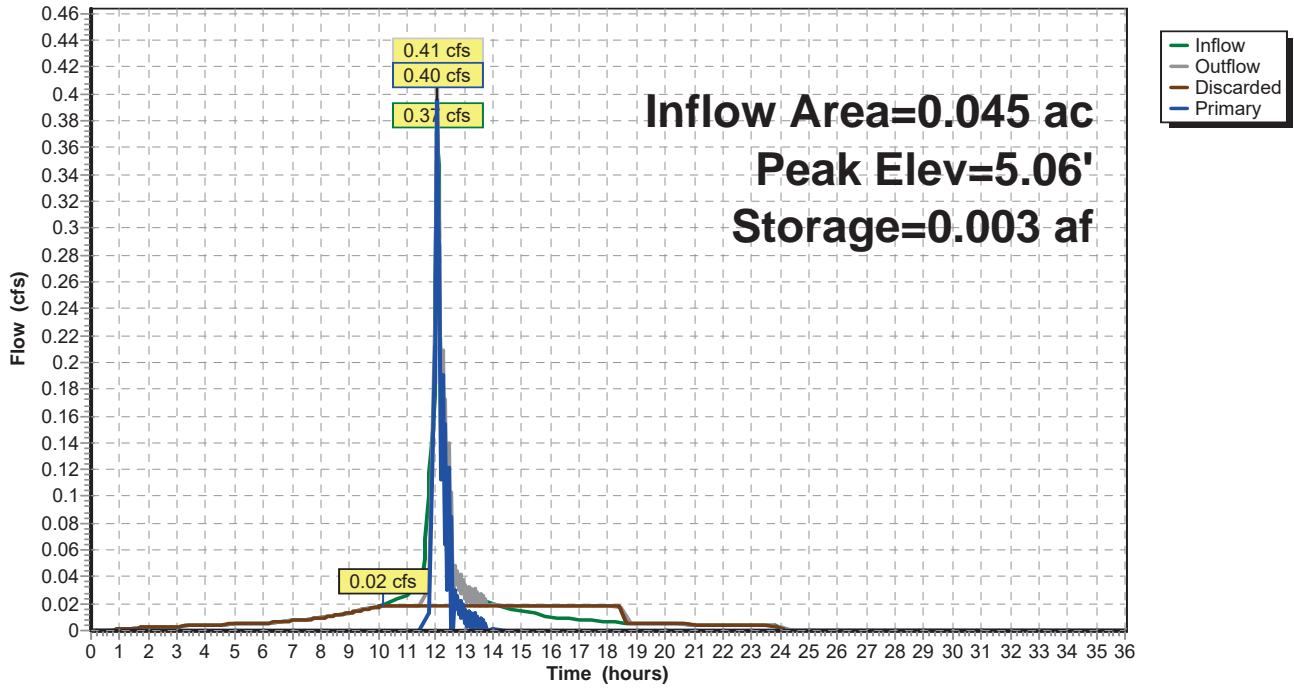
6.4 cy Stone





### Pond 13P: Infiltration

Hydrograph



# Mulberry Subdivision

Prepared by Hildenbrand Engineering, PLLC

HydroCAD® 10.10-6a s/n 11988 © 2020 HydroCAD Software Solutions LLC

Type III 24-hr 100-Year Rainfall=8.26"

Printed 5/1/2023

Page 69

## Summary for Pond 14P: Infiltration

Inflow Area = 0.045 ac, 100.00% Impervious, Inflow Depth = 8.02" for 100-Year event  
 Inflow = 0.37 cfs @ 12.07 hrs, Volume= 0.030 af  
 Outflow = 0.41 cfs @ 12.06 hrs, Volume= 0.030 af, Atten= 0%, Lag= 0.0 min  
 Discarded = 0.02 cfs @ 10.15 hrs, Volume= 0.020 af  
 Primary = 0.40 cfs @ 12.06 hrs, Volume= 0.010 af  
 Routed to Reach 18R : DESIGN LINE

Routing by Stor-Ind method, Time Span= 0.00-36.00 hrs, dt= 0.05 hrs  
 Peak Elev= 5.06' @ 12.06 hrs Surf.Area= 0.002 ac Storage= 0.003 af

Plug-Flow detention time= 33.0 min calculated for 0.030 af (100% of inflow)  
 Center-of-Mass det. time= 33.0 min ( 772.9 - 739.9 )

Volume	Invert	Avail.Storage	Storage Description
#1A	0.00'	0.002 af	<b>6.33'W x 10.50'L x 3.54'H Field A</b> 0.005 af Overall - 0.001 af Embedded = 0.004 af x 40.0% Voids
#2A	0.50'	0.001 af	<b>Cultec R-330XLHD Inside #1</b> Effective Size= 47.8"W x 30.0"H => 7.45 sf x 7.00'L = 52.2 cf Overall Size= 52.0"W x 30.5"H x 8.50'L with 1.50' Overlap Row Length Adjustment= +1.50' x 7.45 sf x 1 rows
		0.003 af	Total Available Storage

Storage Group A created with Chamber Wizard

Device	Routing	Invert	Outlet Devices
#1	Discarded	0.00'	<b>12.000 in/hr Exfiltration over Surface area</b>
#2	Primary	5.00'	<b>24.0" x 24.0" Horiz. Orifice/Grate</b> C= 0.600 Limited to weir flow at low heads

**Discarded OutFlow** Max=0.02 cfs @ 10.15 hrs HW=0.05' (Free Discharge)  
 ↑**1=Exfiltration** (Exfiltration Controls 0.02 cfs)

**Primary OutFlow** Max=0.36 cfs @ 12.06 hrs HW=5.06' (Free Discharge)  
 ↑**2=Orifice/Grate** (Weir Controls 0.36 cfs @ 0.78 fps)

**Mulberry Subdivision**

Prepared by Hildenbrand Engineering, PLLC

HydroCAD® 10.10-6a s/n 11988 © 2020 HydroCAD Software Solutions LLC

Type III 24-hr 100-Year Rainfall=8.26"

Printed 5/1/2023

Page 70

**Pond 14P: Infiltration - Chamber Wizard Field A**

**Chamber Model = Cultec R-330XLHD (Cultec Recharger® 330XLHD)**

Effective Size= 47.8"W x 30.0"H => 7.45 sf x 7.00'L = 52.2 cf

Overall Size= 52.0"W x 30.5"H x 8.50'L with 1.50' Overlap

Row Length Adjustment= +1.50' x 7.45 sf x 1 rows

1 Chambers/Row x 7.00' Long +1.50' Row Adjustment = 8.50' Row Length +12.0" End Stone x 2 = 10.50' Base Length

1 Rows x 52.0" Wide + 12.0" Side Stone x 2 = 6.33' Base Width

6.0" Stone Base + 30.5" Chamber Height + 6.0" Stone Cover = 3.54' Field Height

1 Chambers x 52.2 cf +1.50' Row Adjustment x 7.45 sf x 1 Rows = 63.3 cf Chamber Storage

235.5 cf Field - 63.3 cf Chambers = 172.2 cf Stone x 40.0% Voids = 68.9 cf Stone Storage

Chamber Storage + Stone Storage = 132.2 cf = 0.003 af

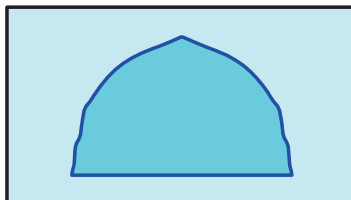
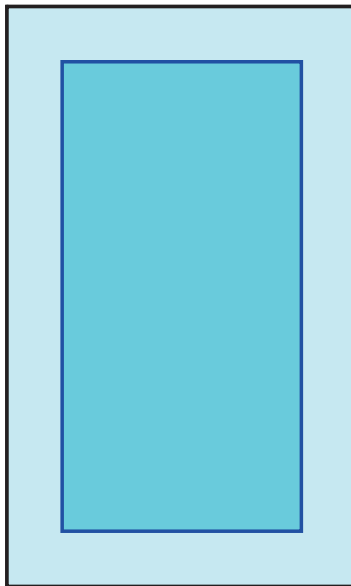
Overall Storage Efficiency = 56.1%

Overall System Size = 10.50' x 6.33' x 3.54'

1 Chambers

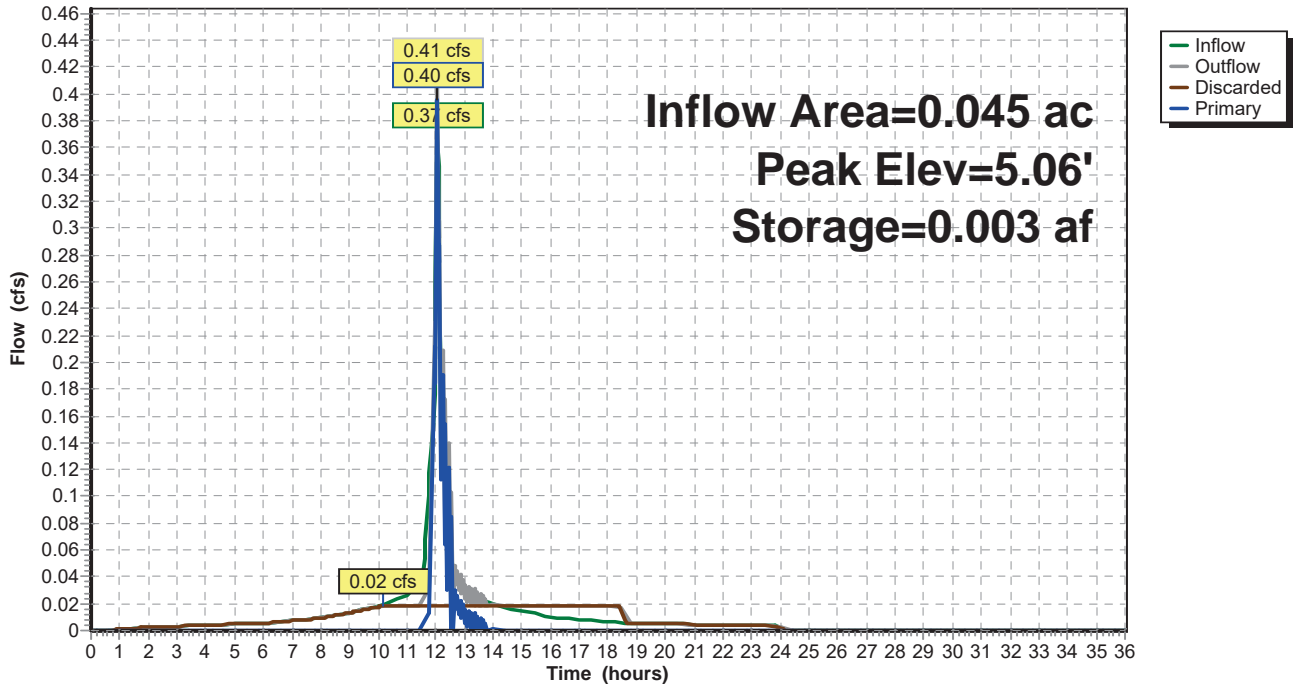
8.7 cy Field

6.4 cy Stone



Pond 14P: Infiltration

Hydrograph



# Mulberry Subdivision

Prepared by Hildenbrand Engineering, PLLC

HydroCAD® 10.10-6a s/n 11988 © 2020 HydroCAD Software Solutions LLC

Type III 24-hr 100-Year Rainfall=8.26"

Printed 5/1/2023

Page 72

## Summary for Pond 15P: Infiltration

Inflow Area = 0.045 ac, 100.00% Impervious, Inflow Depth = 8.02" for 100-Year event  
 Inflow = 0.37 cfs @ 12.07 hrs, Volume= 0.030 af  
 Outflow = 0.41 cfs @ 12.06 hrs, Volume= 0.030 af, Atten= 0%, Lag= 0.0 min  
 Discarded = 0.02 cfs @ 10.15 hrs, Volume= 0.020 af  
 Primary = 0.40 cfs @ 12.06 hrs, Volume= 0.010 af  
 Routed to Reach 18R : DESIGN LINE

Routing by Stor-Ind method, Time Span= 0.00-36.00 hrs, dt= 0.05 hrs  
 Peak Elev= 5.06' @ 12.06 hrs Surf.Area= 0.002 ac Storage= 0.003 af

Plug-Flow detention time= 33.0 min calculated for 0.030 af (100% of inflow)  
 Center-of-Mass det. time= 33.0 min ( 772.9 - 739.9 )

Volume	Invert	Avail.Storage	Storage Description
#1A	0.00'	0.002 af	<b>6.33'W x 10.50'L x 3.54'H Field A</b> 0.005 af Overall - 0.001 af Embedded = 0.004 af x 40.0% Voids
#2A	0.50'	0.001 af	<b>Cultec R-330XLHD Inside #1</b> Effective Size= 47.8"W x 30.0"H => 7.45 sf x 7.00'L = 52.2 cf Overall Size= 52.0"W x 30.5"H x 8.50'L with 1.50' Overlap Row Length Adjustment= +1.50' x 7.45 sf x 1 rows
		0.003 af	Total Available Storage

Storage Group A created with Chamber Wizard

Device	Routing	Invert	Outlet Devices
#1	Discarded	0.00'	<b>12.000 in/hr Exfiltration over Surface area</b>
#2	Primary	5.00'	<b>24.0" x 24.0" Horiz. Orifice/Grate</b> C= 0.600 Limited to weir flow at low heads

**Discarded OutFlow** Max=0.02 cfs @ 10.15 hrs HW=0.05' (Free Discharge)  
 ↑**1=Exfiltration** (Exfiltration Controls 0.02 cfs)

**Primary OutFlow** Max=0.36 cfs @ 12.06 hrs HW=5.06' (Free Discharge)  
 ↑**2=Orifice/Grate** (Weir Controls 0.36 cfs @ 0.78 fps)

# Mulberry Subdivision

Prepared by Hildenbrand Engineering, PLLC

HydroCAD® 10.10-6a s/n 11988 © 2020 HydroCAD Software Solutions LLC

Type III 24-hr 100-Year Rainfall=8.26"

Printed 5/1/2023

Page 73

## Pond 15P: Infiltration - Chamber Wizard Field A

### Chamber Model = Cultec R-330XLHD (Cultec Recharger® 330XLHD)

Effective Size= 47.8"W x 30.0"H => 7.45 sf x 7.00'L = 52.2 cf

Overall Size= 52.0"W x 30.5"H x 8.50'L with 1.50' Overlap

Row Length Adjustment= +1.50' x 7.45 sf x 1 rows

1 Chambers/Row x 7.00' Long +1.50' Row Adjustment = 8.50' Row Length +12.0" End Stone x 2 = 10.50' Base Length

1 Rows x 52.0" Wide + 12.0" Side Stone x 2 = 6.33' Base Width

6.0" Stone Base + 30.5" Chamber Height + 6.0" Stone Cover = 3.54' Field Height

1 Chambers x 52.2 cf +1.50' Row Adjustment x 7.45 sf x 1 Rows = 63.3 cf Chamber Storage

235.5 cf Field - 63.3 cf Chambers = 172.2 cf Stone x 40.0% Voids = 68.9 cf Stone Storage

Chamber Storage + Stone Storage = 132.2 cf = 0.003 af

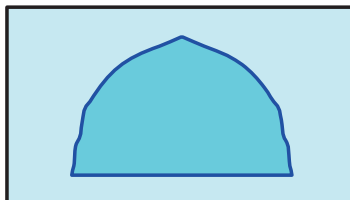
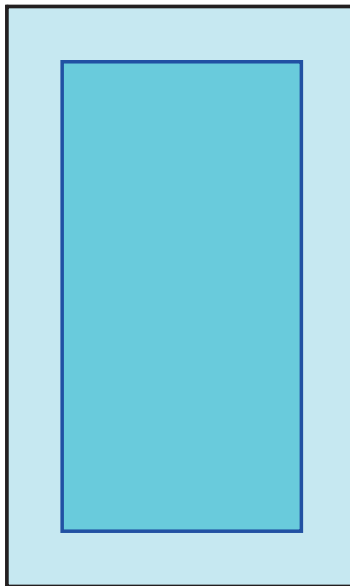
Overall Storage Efficiency = 56.1%

Overall System Size = 10.50' x 6.33' x 3.54'

1 Chambers

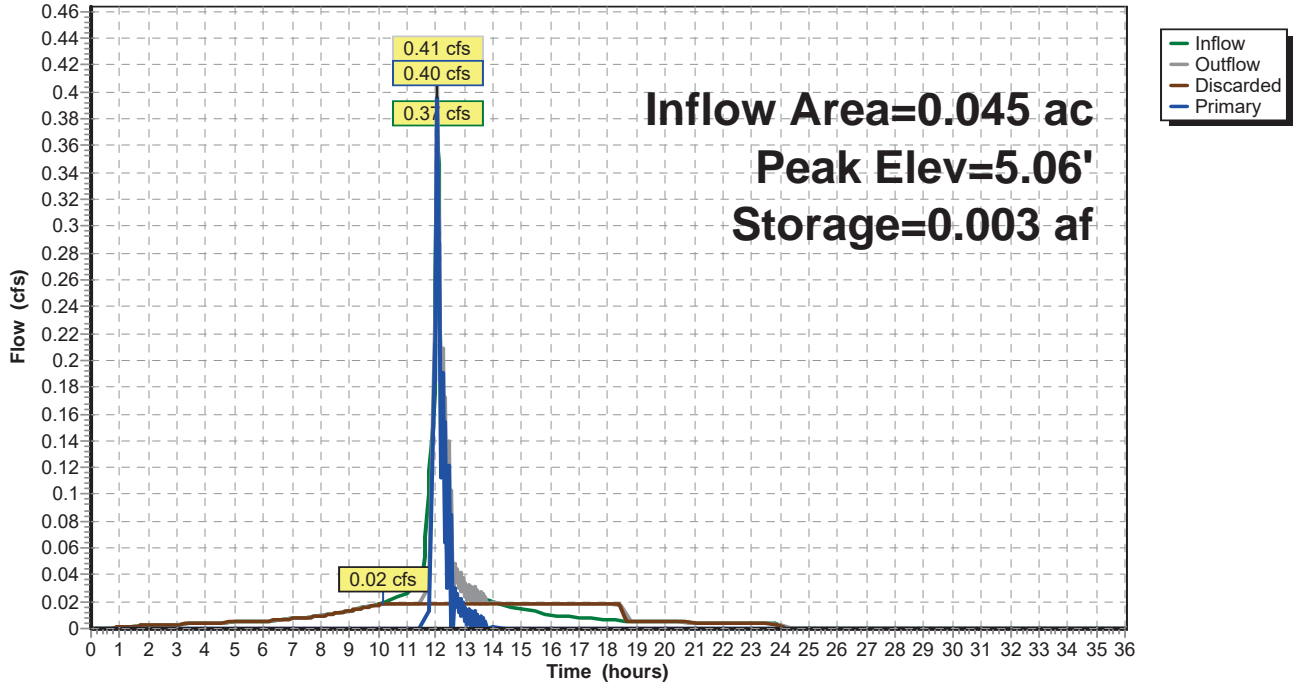
8.7 cy Field

6.4 cy Stone



Pond 15P: Infiltration

Hydrograph



# Mulberry Subdivision

Type III 24-hr 100-Year Rainfall=8.26"

Prepared by Hildenbrand Engineering, PLLC

Printed 5/1/2023

HydroCAD® 10.10-6a s/n 11988 © 2020 HydroCAD Software Solutions LLC

Page 75

## Summary for Pond 16P: Infiltration

Inflow Area = 0.045 ac, 100.00% Impervious, Inflow Depth = 8.02" for 100-Year event  
 Inflow = 0.36 cfs @ 12.07 hrs, Volume= 0.030 af  
 Outflow = 0.42 cfs @ 12.06 hrs, Volume= 0.030 af, Atten= 0%, Lag= 0.0 min  
 Discarded = 0.02 cfs @ 10.20 hrs, Volume= 0.020 af  
 Primary = 0.41 cfs @ 12.06 hrs, Volume= 0.010 af  
 Routed to Reach 18R : DESIGN LINE

Routing by Stor-Ind method, Time Span= 0.00-36.00 hrs, dt= 0.05 hrs  
 Peak Elev= 5.06' @ 12.06 hrs Surf.Area= 0.002 ac Storage= 0.003 af

Plug-Flow detention time= 33.0 min calculated for 0.030 af (100% of inflow)  
 Center-of-Mass det. time= 33.0 min ( 772.9 - 739.9 )

Volume	Invert	Avail.Storage	Storage Description
#1A	0.00'	0.002 af	<b>6.33'W x 10.50'L x 3.54'H Field A</b> 0.005 af Overall - 0.001 af Embedded = 0.004 af x 40.0% Voids
#2A	0.50'	0.001 af	<b>Cultec R-330XLHD Inside #1</b> Effective Size= 47.8"W x 30.0"H => 7.45 sf x 7.00'L = 52.2 cf Overall Size= 52.0"W x 30.5"H x 8.50'L with 1.50' Overlap Row Length Adjustment= +1.50' x 7.45 sf x 1 rows
		0.003 af	Total Available Storage

Storage Group A created with Chamber Wizard

Device	Routing	Invert	Outlet Devices
#1	Discarded	0.00'	<b>12.000 in/hr Exfiltration over Surface area</b>
#2	Primary	5.00'	<b>24.0" x 24.0" Horiz. Orifice/Grate</b> C= 0.600 Limited to weir flow at low heads

**Discarded OutFlow** Max=0.02 cfs @ 10.20 hrs HW=0.05' (Free Discharge)  
 ↑1=Exfiltration (Exfiltration Controls 0.02 cfs)

**Primary OutFlow** Max=0.37 cfs @ 12.06 hrs HW=5.06' (Free Discharge)  
 ↑2=Orifice/Grate (Weir Controls 0.37 cfs @ 0.79 fps)



# Mulberry Subdivision

Prepared by Hildenbrand Engineering, PLLC

HydroCAD® 10.10-6a s/n 11988 © 2020 HydroCAD Software Solutions LLC

Type III 24-hr 100-Year Rainfall=8.26"

Printed 5/1/2023

Page 76

## Pond 16P: Infiltration - Chamber Wizard Field A

### Chamber Model = Cultec R-330XLHD (Cultec Recharger® 330XLHD)

Effective Size= 47.8"W x 30.0"H => 7.45 sf x 7.00'L = 52.2 cf

Overall Size= 52.0"W x 30.5"H x 8.50'L with 1.50' Overlap

Row Length Adjustment= +1.50' x 7.45 sf x 1 rows

1 Chambers/Row x 7.00' Long +1.50' Row Adjustment = 8.50' Row Length +12.0" End Stone x 2 = 10.50' Base Length

1 Rows x 52.0" Wide + 12.0" Side Stone x 2 = 6.33' Base Width

6.0" Stone Base + 30.5" Chamber Height + 6.0" Stone Cover = 3.54' Field Height

1 Chambers x 52.2 cf +1.50' Row Adjustment x 7.45 sf x 1 Rows = 63.3 cf Chamber Storage

235.5 cf Field - 63.3 cf Chambers = 172.2 cf Stone x 40.0% Voids = 68.9 cf Stone Storage

Chamber Storage + Stone Storage = 132.2 cf = 0.003 af

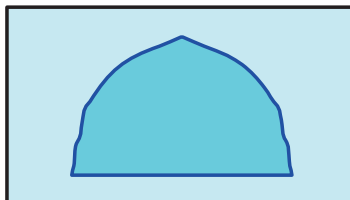
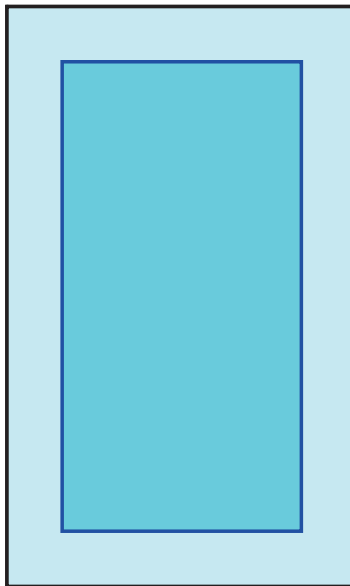
Overall Storage Efficiency = 56.1%

Overall System Size = 10.50' x 6.33' x 3.54'

1 Chambers

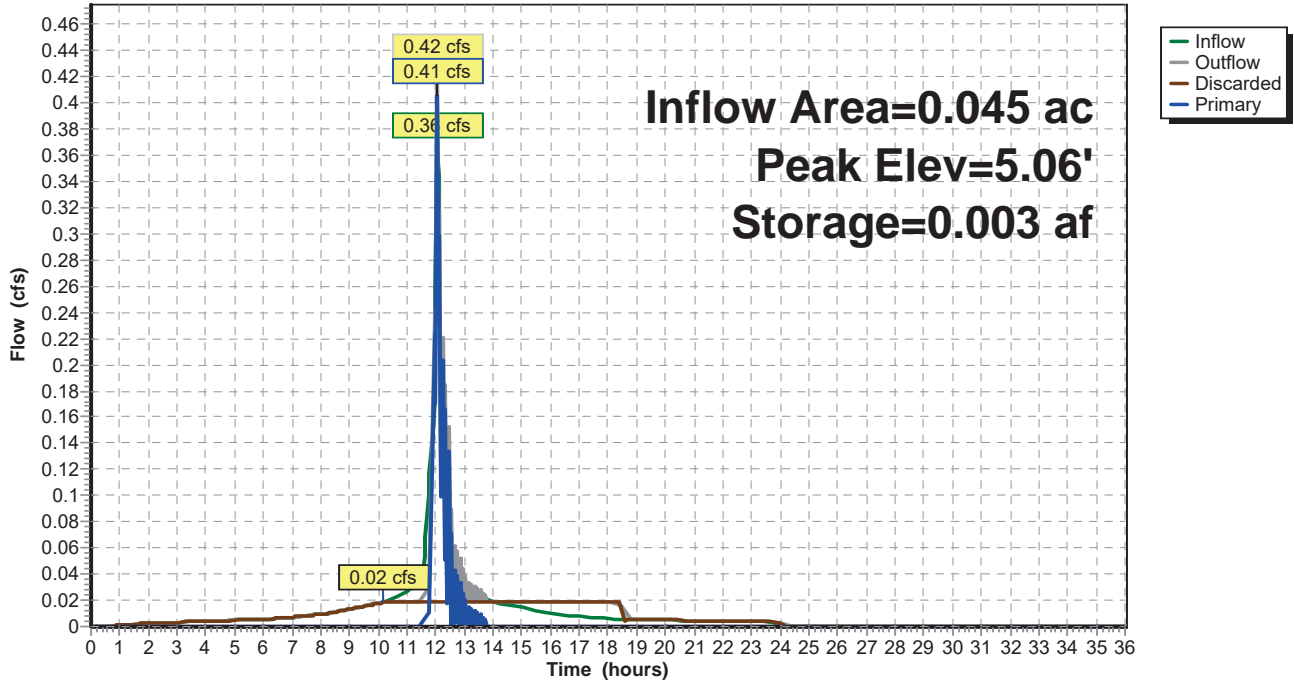
8.7 cy Field

6.4 cy Stone



Pond 16P: Infiltration

Hydrograph



# Mulberry Subdivision

Prepared by Hildenbrand Engineering, PLLC

HydroCAD® 10.10-6a s/n 11988 © 2020 HydroCAD Software Solutions LLC

Type III 24-hr 100-Year Rainfall=8.26"

Printed 5/1/2023

Page 78

## Summary for Pond 17P: Infiltration

Inflow Area = 0.182 ac, 100.00% Impervious, Inflow Depth = 8.02" for 100-Year event  
 Inflow = 1.48 cfs @ 12.07 hrs, Volume= 0.122 af  
 Outflow = 0.57 cfs @ 12.32 hrs, Volume= 0.122 af, Atten= 61%, Lag= 14.9 min  
 Discarded = 0.17 cfs @ 11.55 hrs, Volume= 0.116 af  
 Primary = 0.40 cfs @ 12.32 hrs, Volume= 0.005 af  
 Routed to Reach 18R : DESIGN LINE

Routing by Stor-Ind method, Time Span= 0.00-36.00 hrs, dt= 0.05 hrs  
 Peak Elev= 5.06' @ 12.30 hrs Surf.Area= 0.014 ac Storage= 0.031 af

Plug-Flow detention time= 45.2 min calculated for 0.121 af (100% of inflow)  
 Center-of-Mass det. time= 45.1 min ( 785.0 - 739.9 )

Volume	Invert	Avail.Storage	Storage Description
#1A	0.00'	0.013 af	<b>16.00'W x 38.50'L x 3.54'H Field A</b> 0.050 af Overall - 0.019 af Embedded = 0.031 af x 40.0% Voids
#2A	0.50'	0.019 af	<b>Cultec R-330XLHD x 15 Inside #1</b> Effective Size= 47.8"W x 30.0"H => 7.45 sf x 7.00'L = 52.2 cf Overall Size= 52.0"W x 30.5"H x 8.50'L with 1.50' Overlap Row Length Adjustment= +1.50' x 7.45 sf x 3 rows
		0.031 af	Total Available Storage

Storage Group A created with Chamber Wizard

Device	Routing	Invert	Outlet Devices
#1	Discarded	0.00'	<b>12.000 in/hr Exfiltration over Surface area</b>
#2	Primary	5.00'	<b>24.0" x 24.0" Horiz. Orifice/Grate</b> C= 0.600 Limited to weir flow at low heads

**Discarded OutFlow** Max=0.17 cfs @ 11.55 hrs HW=0.05' (Free Discharge)

↑**1=Exfiltration** (Exfiltration Controls 0.17 cfs)

**Primary OutFlow** Max=0.34 cfs @ 12.32 hrs HW=5.06' (Free Discharge)

↑**2=Orifice/Grate** (Weir Controls 0.34 cfs @ 0.77 fps)

# Mulberry Subdivision

Prepared by Hildenbrand Engineering, PLLC

HydroCAD® 10.10-6a s/n 11988 © 2020 HydroCAD Software Solutions LLC

Type III 24-hr 100-Year Rainfall=8.26"

Printed 5/1/2023

Page 79

## Pond 17P: Infiltration - Chamber Wizard Field A

### Chamber Model = Cultec R-330XLHD (Cultec Recharger® 330XLHD)

Effective Size= 47.8"W x 30.0"H => 7.45 sf x 7.00'L = 52.2 cf

Overall Size= 52.0"W x 30.5"H x 8.50'L with 1.50' Overlap

Row Length Adjustment= +1.50' x 7.45 sf x 3 rows

52.0" Wide + 6.0" Spacing = 58.0" C-C Row Spacing

5 Chambers/Row x 7.00' Long +1.50' Row Adjustment = 36.50' Row Length +12.0" End Stone x 2 = 38.50' Base Length

3 Rows x 52.0" Wide + 6.0" Spacing x 2 + 12.0" Side Stone x 2 = 16.00' Base Width

6.0" Stone Base + 30.5" Chamber Height + 6.0" Stone Cover = 3.54' Field Height

15 Chambers x 52.2 cf +1.50' Row Adjustment x 7.45 sf x 3 Rows = 815.9 cf Chamber Storage

2,181.7 cf Field - 815.9 cf Chambers = 1,365.8 cf Stone x 40.0% Voids = 546.3 cf Stone Storage

Chamber Storage + Stone Storage = 1,362.2 cf = 0.031 af

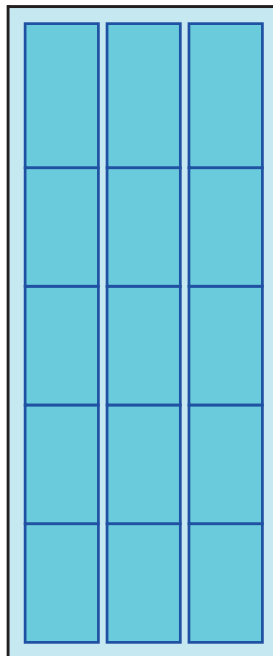
Overall Storage Efficiency = 62.4%

Overall System Size = 38.50' x 16.00' x 3.54'

15 Chambers

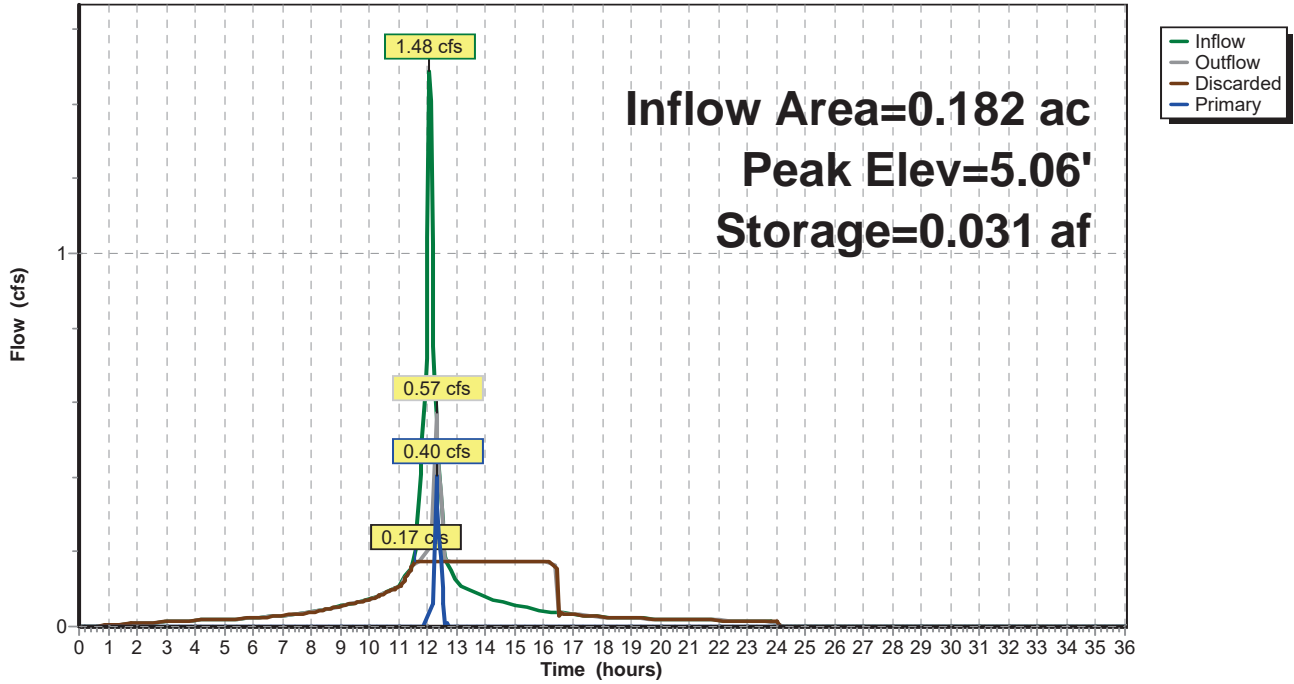
80.8 cy Field

50.6 cy Stone



Pond 17P: Infiltration

Hydrograph





## Appendix B

---

Soil Report





United States  
Department of  
Agriculture

**NRCS**

Natural  
Resources  
Conservation  
Service

A product of the National  
Cooperative Soil Survey,  
a joint effort of the United  
States Department of  
Agriculture and other  
Federal agencies, State  
agencies including the  
Agricultural Experiment  
Stations, and local  
participants

# Custom Soil Resource Report for **Dutchess County, New York**





# Preface

---

Soil surveys contain information that affects land use planning in survey areas. They highlight soil limitations that affect various land uses and provide information about the properties of the soils in the survey areas. Soil surveys are designed for many different users, including farmers, ranchers, foresters, agronomists, urban planners, community officials, engineers, developers, builders, and home buyers. Also, conservationists, teachers, students, and specialists in recreation, waste disposal, and pollution control can use the surveys to help them understand, protect, or enhance the environment.

Various land use regulations of Federal, State, and local governments may impose special restrictions on land use or land treatment. Soil surveys identify soil properties that are used in making various land use or land treatment decisions. The information is intended to help the land users identify and reduce the effects of soil limitations on various land uses. The landowner or user is responsible for identifying and complying with existing laws and regulations.

Although soil survey information can be used for general farm, local, and wider area planning, onsite investigation is needed to supplement this information in some cases. Examples include soil quality assessments (<http://www.nrcs.usda.gov/wps/portal/nrcs/main/soils/health/>) and certain conservation and engineering applications. For more detailed information, contact your local USDA Service Center (<https://offices.sc.egov.usda.gov/locator/app?agency=nrcs>) or your NRCS State Soil Scientist ([http://www.nrcs.usda.gov/wps/portal/nrcs/detail/soils/contactus/?cid=nrcs142p2\\_053951](http://www.nrcs.usda.gov/wps/portal/nrcs/detail/soils/contactus/?cid=nrcs142p2_053951)).

Great differences in soil properties can occur within short distances. Some soils are seasonally wet or subject to flooding. Some are too unstable to be used as a foundation for buildings or roads. Clayey or wet soils are poorly suited to use as septic tank absorption fields. A high water table makes a soil poorly suited to basements or underground installations.

The National Cooperative Soil Survey is a joint effort of the United States Department of Agriculture and other Federal agencies, State agencies including the Agricultural Experiment Stations, and local agencies. The Natural Resources Conservation Service (NRCS) has leadership for the Federal part of the National Cooperative Soil Survey.

Information about soils is updated periodically. Updated information is available through the NRCS Web Soil Survey, the site for official soil survey information.

The U.S. Department of Agriculture (USDA) prohibits discrimination in all its programs and activities on the basis of race, color, national origin, age, disability, and where applicable, sex, marital status, familial status, parental status, religion, sexual orientation, genetic information, political beliefs, reprisal, or because all or a part of an individual's income is derived from any public assistance program. (Not all prohibited bases apply to all programs.) Persons with disabilities who require

alternative means for communication of program information (Braille, large print, audiotape, etc.) should contact USDA's TARGET Center at (202) 720-2600 (voice and TDD). To file a complaint of discrimination, write to USDA, Director, Office of Civil Rights, 1400 Independence Avenue, S.W., Washington, D.C. 20250-9410 or call (800) 795-3272 (voice) or (202) 720-6382 (TDD). USDA is an equal opportunity provider and employer.

# Contents

---

<b>Preface</b> .....	2
<b>Soil Map</b> .....	5
Soil Map.....	6
Legend.....	7
Map Unit Legend.....	8
Map Unit Descriptions.....	8
Dutchess County, New York.....	10
DwC—Dutchess-Cardigan complex, rolling, rocky.....	10
Hf—Haven-Urban land complex.....	12
<b>References</b> .....	14

# Soil Map

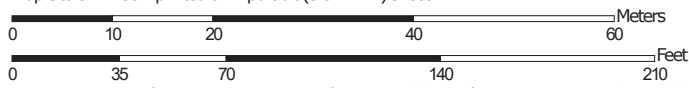
---

The soil map section includes the soil map for the defined area of interest, a list of soil map units on the map and extent of each map unit, and cartographic symbols displayed on the map. Also presented are various metadata about data used to produce the map, and a description of each soil map unit.

# Custom Soil Resource Report Soil Map



Map Scale: 1:753 if printed on A portrait (8.5" x 11") sheet.



Map projection: Web Mercator Corner coordinates: WGS84 Edge tics: UTM Zone 18N WGS84

## MAP LEGEND

<b>Area of Interest (AOI)</b>	 Area of Interest (AOI)	 Spoil Area
<b>Soils</b>	 Soil Map Unit Polygons	 Stony Spot
	 Soil Map Unit Lines	 Very Stony Spot
	 Soil Map Unit Points	 Wet Spot
<b>Special Point Features</b>	 Blowout	 Other
	 Borrow Pit	 Special Line Features
	 Clay Spot	<b>Water Features</b>
	 Closed Depression	 Streams and Canals
	 Gravel Pit	<b>Transportation</b>
	 Gravelly Spot	 Rails
	 Landfill	 Interstate Highways
	 Lava Flow	 US Routes
	 Marsh or swamp	 Major Roads
	 Mine or Quarry	 Local Roads
	 Miscellaneous Water	<b>Background</b>
	 Perennial Water	 Aerial Photography
	 Rock Outcrop	
	 Saline Spot	
	 Sandy Spot	
	 Severely Eroded Spot	
	 Sinkhole	
	 Slide or Slip	
	 Sodic Spot	

## MAP INFORMATION

The soil surveys that comprise your AOI were mapped at 1:24,000.

Warning: Soil Map may not be valid at this scale.

Enlargement of maps beyond the scale of mapping can cause misunderstanding of the detail of mapping and accuracy of soil line placement. The maps do not show the small areas of contrasting soils that could have been shown at a more detailed scale.

Please rely on the bar scale on each map sheet for map measurements.

Source of Map: Natural Resources Conservation Service  
 Web Soil Survey URL:  
 Coordinate System: Web Mercator (EPSG:3857)

Maps from the Web Soil Survey are based on the Web Mercator projection, which preserves direction and shape but distorts distance and area. A projection that preserves area, such as the Albers equal-area conic projection, should be used if more accurate calculations of distance or area are required.

This product is generated from the USDA-NRCS certified data as of the version date(s) listed below.

Soil Survey Area: Dutchess County, New York  
 Survey Area Data: Version 18, Sep 1, 2021

Soil map units are labeled (as space allows) for map scales 1:50,000 or larger.

Date(s) aerial images were photographed: Oct 8, 2020—Oct 14, 2020

The orthophoto or other base map on which the soil lines were compiled and digitized probably differs from the background imagery displayed on these maps. As a result, some minor shifting of map unit boundaries may be evident.

## Map Unit Legend

Map Unit Symbol	Map Unit Name	Acres in AOI	Percent of AOI
DwC	Dutchess-Cardigan complex, rolling, rocky	0.2	8.9%
Hf	Haven-Urban land complex	1.6	91.1%
<b>Totals for Area of Interest</b>		<b>1.7</b>	<b>100.0%</b>

## Map Unit Descriptions

The map units delineated on the detailed soil maps in a soil survey represent the soils or miscellaneous areas in the survey area. The map unit descriptions, along with the maps, can be used to determine the composition and properties of a unit.

A map unit delineation on a soil map represents an area dominated by one or more major kinds of soil or miscellaneous areas. A map unit is identified and named according to the taxonomic classification of the dominant soils. Within a taxonomic class there are precisely defined limits for the properties of the soils. On the landscape, however, the soils are natural phenomena, and they have the characteristic variability of all natural phenomena. Thus, the range of some observed properties may extend beyond the limits defined for a taxonomic class. Areas of soils of a single taxonomic class rarely, if ever, can be mapped without including areas of other taxonomic classes. Consequently, every map unit is made up of the soils or miscellaneous areas for which it is named and some minor components that belong to taxonomic classes other than those of the major soils.

Most minor soils have properties similar to those of the dominant soil or soils in the map unit, and thus they do not affect use and management. These are called noncontrasting, or similar, components. They may or may not be mentioned in a particular map unit description. Other minor components, however, have properties and behavioral characteristics divergent enough to affect use or to require different management. These are called contrasting, or dissimilar, components. They generally are in small areas and could not be mapped separately because of the scale used. Some small areas of strongly contrasting soils or miscellaneous areas are identified by a special symbol on the maps. If included in the database for a given area, the contrasting minor components are identified in the map unit descriptions along with some characteristics of each. A few areas of minor components may not have been observed, and consequently they are not mentioned in the descriptions, especially where the pattern was so complex that it was impractical to make enough observations to identify all the soils and miscellaneous areas on the landscape.

The presence of minor components in a map unit in no way diminishes the usefulness or accuracy of the data. The objective of mapping is not to delineate pure taxonomic classes but rather to separate the landscape into landforms or landform segments that have similar use and management requirements. The delineation of such segments on the map provides sufficient information for the development of resource plans. If intensive use of small areas is planned, however,

## Custom Soil Resource Report

onsite investigation is needed to define and locate the soils and miscellaneous areas.

An identifying symbol precedes the map unit name in the map unit descriptions. Each description includes general facts about the unit and gives important soil properties and qualities.

Soils that have profiles that are almost alike make up a *soil series*. Except for differences in texture of the surface layer, all the soils of a series have major horizons that are similar in composition, thickness, and arrangement.

Soils of one series can differ in texture of the surface layer, slope, stoniness, salinity, degree of erosion, and other characteristics that affect their use. On the basis of such differences, a soil series is divided into *soil phases*. Most of the areas shown on the detailed soil maps are phases of soil series. The name of a soil phase commonly indicates a feature that affects use or management. For example, Alpha silt loam, 0 to 2 percent slopes, is a phase of the Alpha series.

Some map units are made up of two or more major soils or miscellaneous areas. These map units are complexes, associations, or undifferentiated groups.

A *complex* consists of two or more soils or miscellaneous areas in such an intricate pattern or in such small areas that they cannot be shown separately on the maps. The pattern and proportion of the soils or miscellaneous areas are somewhat similar in all areas. Alpha-Beta complex, 0 to 6 percent slopes, is an example.

An *association* is made up of two or more geographically associated soils or miscellaneous areas that are shown as one unit on the maps. Because of present or anticipated uses of the map units in the survey area, it was not considered practical or necessary to map the soils or miscellaneous areas separately. The pattern and relative proportion of the soils or miscellaneous areas are somewhat similar. Alpha-Beta association, 0 to 2 percent slopes, is an example.

An *undifferentiated group* is made up of two or more soils or miscellaneous areas that could be mapped individually but are mapped as one unit because similar interpretations can be made for use and management. The pattern and proportion of the soils or miscellaneous areas in a mapped area are not uniform. An area can be made up of only one of the major soils or miscellaneous areas, or it can be made up of all of them. Alpha and Beta soils, 0 to 2 percent slopes, is an example.

Some surveys include *miscellaneous areas*. Such areas have little or no soil material and support little or no vegetation. Rock outcrop is an example.



## Dutchess County, New York

### DwC—Dutchess-Cardigan complex, rolling, rocky

#### Map Unit Setting

*National map unit symbol:* 9rfp

*Elevation:* 0 to 1,330 feet

*Mean annual precipitation:* 41 to 47 inches

*Mean annual air temperature:* 45 to 50 degrees F

*Frost-free period:* 115 to 195 days

*Farmland classification:* Farmland of statewide importance

#### Map Unit Composition

*Dutchess and similar soils:* 40 percent

*Cardigan and similar soils:* 30 percent

*Minor components:* 30 percent

*Estimates are based on observations, descriptions, and transects of the mapunit.*

#### Description of Dutchess

##### Setting

*Landform:* Ridges, hills

*Landform position (two-dimensional):* Shoulder

*Landform position (three-dimensional):* Crest

*Down-slope shape:* Convex

*Across-slope shape:* Convex

*Parent material:* Loamy till derived mainly from phyllite, slate, schist, and shale

##### Typical profile

*H1 - 0 to 8 inches:* silt loam

*H2 - 8 to 28 inches:* silt loam

*H3 - 28 to 86 inches:* channery silt loam

##### Properties and qualities

*Slope:* 5 to 16 percent

*Depth to restrictive feature:* More than 80 inches

*Drainage class:* Well drained

*Capacity of the most limiting layer to transmit water (Ksat):* Moderately high to high  
(0.57 to 1.98 in/hr)

*Depth to water table:* More than 80 inches

*Frequency of flooding:* None

*Frequency of ponding:* None

*Available water supply, 0 to 60 inches:* High (about 9.6 inches)

##### Interpretive groups

*Land capability classification (irrigated):* None specified

*Land capability classification (nonirrigated):* 3e

*Hydrologic Soil Group:* B

*Ecological site:* F144AY034CT - Well Drained Till Uplands

*Hydric soil rating:* No

#### Description of Cardigan

##### Setting

*Landform:* Ridges, hills

*Landform position (two-dimensional):* Shoulder

## Custom Soil Resource Report

*Landform position (three-dimensional):* Crest

*Down-slope shape:* Convex

*Across-slope shape:* Convex

*Parent material:* Loamy till or colluvium derived from phyllite, slate, shale, and schist

### Typical profile

*H1 - 0 to 8 inches:* channery silt loam

*H2 - 8 to 20 inches:* channery loam

*H3 - 20 to 30 inches:* channery silt loam

*H4 - 30 to 34 inches:* unweathered bedrock

### Properties and qualities

*Slope:* 5 to 16 percent

*Depth to restrictive feature:* 20 to 40 inches to lithic bedrock

*Drainage class:* Well drained

*Capacity of the most limiting layer to transmit water (Ksat):* Low to moderately low  
(0.00 to 0.06 in/hr)

*Depth to water table:* More than 80 inches

*Frequency of flooding:* None

*Frequency of ponding:* None

*Available water supply, 0 to 60 inches:* Low (about 4.1 inches)

### Interpretive groups

*Land capability classification (irrigated):* None specified

*Land capability classification (nonirrigated):* 3e

*Hydrologic Soil Group:* C

*Ecological site:* F144AY034CT - Well Drained Till Uplands

*Hydric soil rating:* No

### Minor Components

#### Georgia

*Percent of map unit:* 10 percent

*Hydric soil rating:* No

#### Nassau

*Percent of map unit:* 9 percent

*Hydric soil rating:* No

#### Massena

*Percent of map unit:* 9 percent

*Hydric soil rating:* No

#### Rock outcrop

*Percent of map unit:* 1 percent

*Hydric soil rating:* Unranked

#### Sun

*Percent of map unit:* 1 percent

*Landform:* Depressions

*Hydric soil rating:* Yes

## Hf—Haven-Urban land complex

### Map Unit Setting

*National map unit symbol:* 9rgc  
*Elevation:* 160 to 230 feet  
*Mean annual precipitation:* 41 to 47 inches  
*Mean annual air temperature:* 45 to 50 degrees F  
*Frost-free period:* 115 to 195 days  
*Farmland classification:* Not prime farmland

### Map Unit Composition

*Haven and similar soils:* 40 percent  
*Urban land:* 35 percent  
*Minor components:* 25 percent  
*Estimates are based on observations, descriptions, and transects of the mapunit.*

### Description of Haven

#### Setting

*Landform:* Outwash plains  
*Landform position (two-dimensional):* Summit  
*Landform position (three-dimensional):* Tread  
*Down-slope shape:* Convex  
*Across-slope shape:* Convex  
*Parent material:* Loamy glaciofluvial deposits over sandy and gravelly glaciofluvial deposits

#### Typical profile

*H1 - 0 to 12 inches:* loam  
*H2 - 12 to 23 inches:* gravelly loam  
*H3 - 23 to 72 inches:* stratified very gravelly sand

#### Properties and qualities

*Slope:* 0 to 3 percent  
*Depth to restrictive feature:* More than 80 inches  
*Drainage class:* Well drained  
*Capacity of the most limiting layer to transmit water (Ksat):* Moderately high to high (0.57 to 1.98 in/hr)  
*Depth to water table:* More than 80 inches  
*Frequency of flooding:* None  
*Frequency of ponding:* None  
*Available water supply, 0 to 60 inches:* Low (about 4.2 inches)

#### Interpretive groups

*Land capability classification (irrigated):* None specified  
*Land capability classification (nonirrigated):* 1  
*Hydrologic Soil Group:* B  
*Ecological site:* F144AY023CT - Well Drained Outwash  
*Hydric soil rating:* No

**Description of Urban Land**

**Typical profile**

*H1 - 0 to 6 inches: variable*

**Interpretive groups**

*Land capability classification (irrigated): None specified*

*Land capability classification (nonirrigated): 8s*

*Hydric soil rating: Unranked*

**Minor Components**

**Udorthents**

*Percent of map unit: 10 percent*

*Hydric soil rating: No*

**Hoosic**

*Percent of map unit: 5 percent*

*Hydric soil rating: No*

**Knickerbocker**

*Percent of map unit: 5 percent*

*Hydric soil rating: No*

**Fredon**

*Percent of map unit: 4 percent*

*Landform: Depressions*

*Hydric soil rating: Yes*

**Halsey**

*Percent of map unit: 1 percent*

*Landform: Depressions*

*Hydric soil rating: Yes*

# References

---

- American Association of State Highway and Transportation Officials (AASHTO). 2004. Standard specifications for transportation materials and methods of sampling and testing. 24th edition.
- American Society for Testing and Materials (ASTM). 2005. Standard classification of soils for engineering purposes. ASTM Standard D2487-00.
- Cowardin, L.M., V. Carter, F.C. Golet, and E.T. LaRoe. 1979. Classification of wetlands and deep-water habitats of the United States. U.S. Fish and Wildlife Service FWS/OBS-79/31.
- Federal Register. July 13, 1994. Changes in hydric soils of the United States.
- Federal Register. September 18, 2002. Hydric soils of the United States.
- Hurt, G.W., and L.M. Vasilas, editors. Version 6.0, 2006. Field indicators of hydric soils in the United States.
- National Research Council. 1995. Wetlands: Characteristics and boundaries.
- Soil Survey Division Staff. 1993. Soil survey manual. Soil Conservation Service. U.S. Department of Agriculture Handbook 18. [http://www.nrcs.usda.gov/wps/portal/nrcs/detail/national/soils/?cid=nrcs142p2\\_054262](http://www.nrcs.usda.gov/wps/portal/nrcs/detail/national/soils/?cid=nrcs142p2_054262)
- Soil Survey Staff. 1999. Soil taxonomy: A basic system of soil classification for making and interpreting soil surveys. 2nd edition. Natural Resources Conservation Service, U.S. Department of Agriculture Handbook 436. [http://www.nrcs.usda.gov/wps/portal/nrcs/detail/national/soils/?cid=nrcs142p2\\_053577](http://www.nrcs.usda.gov/wps/portal/nrcs/detail/national/soils/?cid=nrcs142p2_053577)
- Soil Survey Staff. 2010. Keys to soil taxonomy. 11th edition. U.S. Department of Agriculture, Natural Resources Conservation Service. [http://www.nrcs.usda.gov/wps/portal/nrcs/detail/national/soils/?cid=nrcs142p2\\_053580](http://www.nrcs.usda.gov/wps/portal/nrcs/detail/national/soils/?cid=nrcs142p2_053580)
- Tiner, R.W., Jr. 1985. Wetlands of Delaware. U.S. Fish and Wildlife Service and Delaware Department of Natural Resources and Environmental Control, Wetlands Section.
- United States Army Corps of Engineers, Environmental Laboratory. 1987. Corps of Engineers wetlands delineation manual. Waterways Experiment Station Technical Report Y-87-1.
- United States Department of Agriculture, Natural Resources Conservation Service. National forestry manual. [http://www.nrcs.usda.gov/wps/portal/nrcs/detail/soils/home/?cid=nrcs142p2\\_053374](http://www.nrcs.usda.gov/wps/portal/nrcs/detail/soils/home/?cid=nrcs142p2_053374)
- United States Department of Agriculture, Natural Resources Conservation Service. National range and pasture handbook. <http://www.nrcs.usda.gov/wps/portal/nrcs/detail/national/landuse/rangepasture/?cid=stelprdb1043084>

## Custom Soil Resource Report

United States Department of Agriculture, Natural Resources Conservation Service. National soil survey handbook, title 430-VI. [http://www.nrcs.usda.gov/wps/portal/nrcs/detail/soils/scientists/?cid=nrcs142p2\\_054242](http://www.nrcs.usda.gov/wps/portal/nrcs/detail/soils/scientists/?cid=nrcs142p2_054242)

United States Department of Agriculture, Natural Resources Conservation Service. 2006. Land resource regions and major land resource areas of the United States, the Caribbean, and the Pacific Basin. U.S. Department of Agriculture Handbook 296. [http://www.nrcs.usda.gov/wps/portal/nrcs/detail/national/soils/?cid=nrcs142p2\\_053624](http://www.nrcs.usda.gov/wps/portal/nrcs/detail/national/soils/?cid=nrcs142p2_053624)

United States Department of Agriculture, Soil Conservation Service. 1961. Land capability classification. U.S. Department of Agriculture Handbook 210. [http://www.nrcs.usda.gov/Internet/FSE\\_DOCUMENTS/nrcs142p2\\_052290.pdf](http://www.nrcs.usda.gov/Internet/FSE_DOCUMENTS/nrcs142p2_052290.pdf)





## Appendix C

---

### Precipitation Data





# Extreme Precipitation Tables

## Northeast Regional Climate Center

Data represents point estimates calculated from partial duration series. All precipitation amounts are displayed in inches.

Metadata for Point	
Smoothing	Yes
State	New York
Location	New York, United States
Latitude	41.927 degrees North
Longitude	73.908 degrees West
Elevation	60 feet
Date/Time	Tue Apr 04 2023 20:53:09 GMT-0400 (Eastern Daylight Time)

### Extreme Precipitation Estimates

	5min	10min	15min	30min	60min	120min		1hr	2hr	3hr	6hr	12hr	24hr	48hr	
1yr	0.30	0.46	0.58	0.76	0.94	1.18	1yr	0.81	1.10	1.36	1.69	2.09	2.59	2.97	1yr
2yr	0.37	0.56	0.70	0.92	1.16	1.45	2yr	1.00	1.33	1.67	2.07	2.55	3.13	3.55	2yr
5yr	0.43	0.67	0.84	1.13	1.44	1.83	5yr	1.25	1.65	2.11	2.61	3.21	3.93	4.51	5yr
10yr	0.49	0.76	0.96	1.31	1.70	2.17	10yr	1.47	1.94	2.51	3.11	3.82	4.66	5.40	10yr
25yr	0.57	0.90	1.15	1.60	2.12	2.73	25yr	1.83	2.40	3.18	3.94	4.82	5.85	6.86	25yr
50yr	0.65	1.04	1.33	1.86	2.51	3.25	50yr	2.17	2.83	3.79	4.70	5.75	6.95	8.23	50yr
100yr	0.74	1.19	1.54	2.18	2.98	3.88	100yr	2.57	3.34	4.53	5.62	6.85	8.26	9.87	100yr
200yr	0.85	1.38	1.79	2.56	3.53	4.62	200yr	3.05	3.94	5.40	6.71	8.17	9.82	11.86	200yr
500yr	1.02	1.68	2.19	3.17	4.44	5.84	500yr	3.83	4.90	6.83	8.49	10.32	12.36	15.12	500yr

### Lower Confidence Limits

	5min	10min	15min	30min	60min	120min		1hr	2hr	3hr	6hr	12hr	24hr	48hr	
1yr	0.27	0.41	0.50	0.67	0.83	0.95	1yr	0.71	0.93	1.16	1.40	1.75	2.25	2.64	1yr
2yr	0.35	0.55	0.67	0.91	1.13	1.31	2yr	0.97	1.28	1.47	1.90	2.41	3.04	3.45	2yr
5yr	0.39	0.60	0.75	1.03	1.31	1.52	5yr	1.13	1.48	1.71	2.20	2.77	3.64	4.16	5yr
10yr	0.43	0.66	0.82	1.15	1.48	1.69	10yr	1.28	1.65	1.90	2.45	3.06	4.12	4.78	10yr
25yr	0.49	0.75	0.93	1.33	1.75	1.92	25yr	1.51	1.88	2.16	2.76	3.46	4.94	5.75	25yr
50yr	0.54	0.83	1.03	1.48	2.00	2.11	50yr	1.72	2.06	2.38	3.06	3.81	5.65	6.61	50yr
100yr	0.61	0.92	1.15	1.66	2.27	2.33	100yr	1.96	2.27	2.64	3.39	4.19	6.50	7.61	100yr
200yr	0.68	1.02	1.30	1.88	2.62	2.54	200yr	2.26	2.48	2.91	3.77	4.57	7.46	8.79	200yr
500yr	0.80	1.19	1.54	2.23	3.18	2.88	500yr	2.74	2.82	3.32	4.34	5.12	9.03	10.64	500yr

### Upper Confidence Limits

	5min	10min	15min	30min	60min	120min		1hr	2hr	3hr	6hr	12hr	24hr	48hr	
1yr	0.33	0.52	0.63	0.85	1.04	1.25	1yr	0.90	1.22	1.38	1.79	2.27	2.83	3.23	1yr
2yr	0.38	0.59	0.73	0.99	1.22	1.45	2yr	1.05	1.42	1.63	2.10	2.65	3.26	3.71	2yr
5yr	0.47	0.73	0.90	1.24	1.57	1.85	5yr	1.36	1.81	2.13	2.75	3.44	4.24	4.87	5yr
10yr	0.56	0.86	1.06	1.48	1.91	2.27	10yr	1.65	2.22	2.61	3.40	4.22	5.25	6.03	10yr
25yr	0.70	1.06	1.32	1.88	2.48	2.97	25yr	2.14	2.91	3.45	4.58	5.55	6.80	8.00	25yr
50yr	0.83	1.26	1.56	2.25	3.03	3.66	50yr	2.61	3.57	4.27	5.70	6.87	8.33	9.90	50yr





## Appendix D

---

WQv and RRv Calculations



Is this project subject to Chapter 10 of the NYS Design Manual (i.e. WQv is equal to post-development 1 year runoff volume)?..... **No**

Design Point: Design Line  
 P= 1.30 inch *Manually enter P, Total Area and Impervious Cover.*

**Breakdown of Subcatchments**

Catchment Number	Total Area (Acres)	Impervious Area (Acres)	Percent Impervious %	Rv	WQv (ft <sup>3</sup> )	Description
1	0.18	0.06	33%	0.35	297	Dry Well
2	0.19	0.06	32%	0.33	300	Dry Well
3	0.67	0.36	54%	0.53	1,687	Dry Well
4	0.20	0.06	30%	0.32	302	Dry Well
5	0.20	0.07	35%	0.37	344	Dry Well
6						
7						
8						
9						
10						
Subtotal (1-30)	1.44	0.61	42%	0.43	<b>2,930</b>	<b>Subtotal 1</b>
<b>Total</b>	1.44	0.61	42%	0.43	<b>2,930</b>	<b>Initial WQv</b>

**0.07 af**

**Identify Runoff Reduction Techniques By Area**

Technique	Total Contributing Area (Acre)	Contributing Impervious Area (Acre)	Notes
Conservation of Natural Areas	0.00	0.00	<i>minimum 10,000 sf</i>
Riparian Buffers	0.00	0.00	<i>maximum contributing length 75 feet to 150 feet</i>
Filter Strips	0.00	0.00	
Tree Planting	0.00	0.00	<i>Up to 100 sf directly connected impervious area may be subtracted per tree</i>
<b>Total</b>	<b>0.00</b>	<b>0.00</b>	

**Recalculate WQv after application of Area Reduction Techniques**

	Total Area (Acres)	Impervious Area (Acres)	Percent Impervious %	Runoff Coefficient Rv	WQv (ft <sup>3</sup> )
"<<Initial WQv"	1.44	0.61	42%	0.43	2,930
Subtract Area	0.00	0.00			
WQv adjusted after Area Reductions	<b>1.44</b>	<b>0.61</b>	42%	0.43	2,930
Disconnection of Rooftops		0.00			
Adjusted WQv after Area Reduction and Rooftop Disconnect	1.44	0.61	42%	0.43	<b>2,930</b>
WQv reduced by Area Reduction techniques					0

**0.07 af**

**0.00 af**

Total Water Quality Volume Calculation

$$WQv(\text{acre-feet}) = [(P)(Rv)(A)] / 12$$

All Subcatchments						
Catchment	Total Area (Acres)	Impervious Cover (Acres)	Percent Impervious %	Runoff Coefficient Rv	WQv (ft <sup>3</sup> )	Description
1	0.18	0.06	0.33	0.35	297.30	Dry Well
2	0.19	0.06	0.32	0.33	300	Dry Well
3	0.67	0.36	0.54	0.53	1687.04	Dry Well
4	0.20	0.06	0.30	0.32	302.02	Dry Well
5	0.20	0.07	0.35	0.37	344.49	Dry Well
6						
7						
8						
9						
10						
11						
12						
13						
14						
15						
16						
17						
18						
19						
20						
21						
22						
23						
24						
25						
26						
27						
28						
29						
30						

# Minimum RRv

**Enter the Soils Data for the site**

Soil Group	Acres	S
A		55%
B	0.00	40%
C	1.44	30%
D	<b>0.00</b>	20%
Total Area	1.44	

**Calculate the Minimum RRv**

S =	<b>0.30</b>	
Impervious =	0.61	<i>acre</i>
Precipitation	1.3	<i>in</i>
Rv	0.95	
<b>Minimum RRv</b>	<b>820</b>	<b><i>ft3</i></b>
	0.02	<i>af</i>



# Planning

Practice	Description	Application
<b>Preservation of Undisturbed Areas</b>	Delineate and place into permanent conservation undisturbed forests, native vegetated areas, riparian corridors, wetlands, and natural terrain.	Considered & Applied
<b>Preservation of Buffers</b>	Define, delineate and preserve naturally vegetated buffers along perennial streams, rivers, shorelines and wetlands.	Considered & Applied
<b>Reduction of Clearing and Grading</b>	Limit clearing and grading to the minimum amount needed for roads, driveways, foundations, utilities and stormwater management facilities.	Considered & Applied
<b>Locating Development in Less Sensitive Areas</b>	Avoid sensitive resource areas such as floodplains, steep slopes, erodible soils, wetlands, mature forests and critical habitats by locating development to fit the terrain in areas that will create the least impact.	Considered & Applied
<b>Open Space Design</b>	Use clustering, conservation design or open space design to reduce impervious cover, preserve more open space and protect water resources.	Considered & Applied
<b>Soil Restoration</b>	Restore the original properties and porosity of the soil by deep till and amendment with compost to reduce the generation of runoff and enhance the runoff reduction performance of post construction practices.	N/A
<b>Roadway Reduction</b>	Minimize roadway widths and lengths to reduce site impervious area	N/A
<b>Sidewalk Reduction</b>	Minimize sidewalk lengths and widths to reduce site impervious area	Considered & Applied
<b>Driveway Reduction</b>	Minimize driveway lengths and widths to reduce site impervious area	Considered & Applied
<b>Cul-de-sac Reduction</b>	Minimize the number of cul-de-sacs and incorporate landscaped areas to reduce their impervious cover.	N/A
<b>Building Footprint Reduction</b>	Reduce the impervious footprint of residences and commercial buildings by using alternate or taller buildings while maintaining the same floor to area ratio.	N/A
<b>Parking Reduction</b>	Reduce imperviousness on parking lots by eliminating unneeded spaces, providing compact car spaces and efficient parking lanes, minimizing stall dimensions, using porous pavement surfaces in overflow parking areas, and using multi-storied parking decks where appropriate.	

# Exhibit B

September 5, 2023 **REVISION 1**

Dutchess Shepherd LLC

c/a NAVA

Attn: David Ruff, AIA ([david@nava.nyc](mailto:david@nava.nyc))

**RE: Traffic Impact Study for Residential Development, 6 Mulberry Street, Village of Rhinebeck, Dutchess County, New York; CM Project No. 123-020**

Dear Mr. Ruff:

As requested, Creighton Manning Engineering, LLP (CM) has completed a revised Traffic Impact Study for the proposed residential development located on Mulberry Street in the Village of Rhinebeck, Dutchess County, NY. This study, which was revised according to feedback from Tighe & Bond Engineering and Landscape Architecture in its letter dated June 28, 2023, is based on traffic engineering industry standards and the Subdivision Plan prepared by NAVA Partners LLC, which is included under Attachment A.

### **1.0 Project Description**

The subject site is defined on the Dutchess County Tax Map as Section 19, Block 1, Lot 10, and is developed with a three-story building previously occupied by Bulkeley Schoolhouse elementary school in the 20<sup>th</sup> century. The property continues to be used for community and educational purposes including basketball leagues and private educational uses. The site is accessed via an existing driveway on Mulberry Street approximately 90-feet north of South Street. The proposed project consists of subdividing and redeveloping the property by repurposing the existing building into a multi-family residential building with nine units (on newly created Lot 3) and constructing four detached single-family homes on the remaining four lots (on newly created Lots 1, 2, 4 and 5). The multi-family residential building will be accessed via a driveway on Mulberry Street approximately 180 feet north of South Street and each single-family home will be accessed via a private driveway on either Mulberry Street or South Street. The residential building will be supported 18 parking spaces inclusive of two ADA-accessible spaces. The proposed development is expected to be completed by 2025. A map illustrating the site location is shown in Exhibit 1.



**Exhibit 1 – Site Location**

## 2.0 Existing Conditions

### Roadways Serving the Site

- **East Market Street (NYS Route 308)** is classified as a Rural Major Collector roadway and is under the jurisdiction of the New York State Department of Transportation (NYSDOT). The roadway runs primarily east-west from NYS Route 199 in the Town of Red Hook to US Route 9 in the Town of Rhinebeck. In the vicinity of the site, East Market Street provides one 12-foot-wide travel lane in each direction with on-street parking on both sides of the road. Turn lanes are generally not provided at intersections or driveways. The posted speed limit is 30 miles per hour.
- **Mulberry Street** is classified as a Rural Local roadway and is under the jurisdiction of the Village of Rhinebeck. The roadway runs north-south from US Route 9 to South Street within the Village. In the vicinity of the site, Mulberry Street provides a 33-foot-wide cross-section for two-way travel and on-street parking on both sides of the road. Turn lanes are not provided at intersections or driveways. The posted speed limit 30 miles per house. Sidewalks are provided on both sides of the roadway.
- **South Street** is classified as a Rural Local roadway and is under the jurisdiction of the Village of Rhinebeck. The roadway runs east-west from East-Market Street to Mill Street within the Village. In the vicinity of the site, South Street provides a 35-foot-wide cross-section for a two-way travel and on-street parking on both side of the road. Turn lanes are not provided at intersections or driveways. The posted speed-limit 30 miles per house. Sidewalks are provided on both sides of the roadway.
- **North/South Parsonage Street:** is classified as a Rural Local roadway and is under the jurisdiction of the Village of Rhinebeck. The roadway runs north-south-west from 4H Hill Lane to Mill Street within the Village. In the vicinity of the site, North/South Parsonage Street provides a 30-foot-wide cross-section for one-way and two-way travel on different segments of the road. Turn lanes are not provided at intersections or driveways. The posted speed limit 30 miles per house. Sidewalks are provided on both sides of the roadway.

### Study Intersections

- **East Market Street/Mulberry Street:** This is a four-leg unsignalized intersection operating with stop control on the northbound and southbound approaches. The eastbound, westbound, northbound, and southbound intersection approaches each provide one shared left-turn/through/right-turn lane. Marked crosswalks are provided on the east and south legs of the intersection. Curb ramps are present on all corners of the intersection. Exhibit 2 depicts the intersection.



Exhibit 2 – East Market St and Mulberry St Intersection

- **East Market Street/North Parsonage Street:** This is a four-leg unsignalized intersection operating with stop control on the southbound approach. The eastbound East Market Street approach provides one shared left-turn/through/right-turn lane. The westbound East Market Street approach provides one shared left-turn/through/right-turn lane. There is no northbound approach since North Parsonage Street is one-way southbound. The southbound North Parsonage Street approach provides one shared left-turn/through/right-turn lane. Curb ramps are present on all corners. Exhibit 3 depicts the intersection.



Exhibit 3 – East Market St and North Parsonage St Intersection

- **South Street/Mulberry Street:** This is a three-way unsignalized intersection operating with stop control on the southbound approach. The eastbound South Street approach provides one shared left-turn/through lane. The westbound South Street approach provides one shared through/right-turn lane. The southbound Mulberry Street approach provides a shared left-turn/right-turn lane. Curb ramps are present on northeast and northwest corners of the intersection. Exhibit 4 depicts the intersection.



Exhibit 4 – South St and Mulberry St Intersection

- **South Street/North Parsonage Street/South Parsonage Street:** This is a four-leg unsignalized intersection operating with stop control on the eastbound and westbound approaches. The eastbound South Street approach provides one shared through/right-turn lane. The westbound South Street approach provides one shared left-turn/through lane. The northbound South Parsonage Street approach provides one shared left-turn/right-turn lane. The southbound North Parsonage Street approach provides one shared left-turn/through/right-turn lane. Curb ramps are present on the northeast, northwest, and southwest corners of the intersection. Exhibit 5 depicts the intersection.



Exhibit 5 – South St/N. Parsonage St/S. Parsonage St Intersection

**Motor Vehicle Collision Analysis**

Motor vehicle collision data for the aforementioned study intersections was obtained from the NYS DOT from December 31, 2019 to December 31, 2022 period. Tables 1-3 summarize the collision type and severity of the reported vehicle collision at each intersection. It should be noted that there no collisions reported at the South Street/Mulberry Street intersection.

**Table 1 – Summary of Motor Vehicle Collisions**

Location	Collision Type	Number of Collisions	Number of Collisions Resulting in Injury	Number of Collisions Resulting in Fatalities
East Market St & Mulberry St Intersection	Rear End	0	0	0
	Overtaking	0	0	0
	Head-on	0	0	0
	Left-Turn	0	0	0
	Right Angle	1	0	0
	Right Turn	0	0	0
	Collision with Fixed Object	0	0	0
	Collision with Animal	0	0	0
	Other	0	0	0
Total		1	0	0

**Table 2 – Summary of Motor Vehicle Collisions**

Location	Collision Type	Number of Collisions	Number of Collisions Resulting in Injury	Number of Collisions Resulting in Fatalities
East Market St & N. Parsonage St Intersection	Rear End	0	0	0
	Overtaking	0	0	0
	Head-on	0	0	0
	Left-Turn	1	0	0
	Right Angle	2	1	0
	Right Turn	0	0	0
	Collision with Fixed Object	0	0	0
	Collision with Animal	0	0	0
	Other	0	0	0
Total		3	1	0

**Table 3 – Summary of Motor Vehicle Collisions**

Location	Collision Type	Number of Collisions	Number of Collisions Resulting in Injury	Number of Collisions Resulting in Fatalities
South St & N. Parsonage St/S. Parsonage St Intersection	Rear End	0	0	0
	Overtaking	0	0	0
	Head-on	0	0	0
	Left-Turn	0	0	0
	Right Angle	4	1	0
	Right Turn	0	0	0
	Collision with Fixed Object	0	0	0
	Collision with Animal	0	0	0
	Other	0	0	0
Total		4	1	0

- **East Market Street/Mulberry Street:** Table 1 shows that one collision was reported at the intersection over the three-year period. This collision was a right-angle collision, and the apparent contributing factor was failure to yield right of way. This crash did not result in an injury or fatality. There no collisions involving a pedestrian or bicyclist.
- **East Market Street/N. Parsonage Street:** Table 2 shows that three collisions were reported at the intersection over the three-year period. Out of those three collisions, one resulted in an injury. The data received reports that the collisions occurred due to failure to yield right of way and driver inattention. There were zero collisions resulting in fatality. There no collisions involving a pedestrian or bicyclist.
- **South Street/N. Parsonage Street/S. Parsonage Street:** Table 3 shows that four collisions were reported at the intersection over the three-year period. Out of those four collisions, one resulted in an injury. The data received reports that the collisions occurred due to failure to yield right of way with all collisions being right-angle collisions. There were zero collisions resulting in fatality. There no collisions involving a pedestrian or bicyclist.

#### Data Collection

Turning Movement Counts (TMCs) were conducted on Wednesday, March 1, 2023, during the weekday morning (7:00AM - 9:00AM), weekday school dismissal (2:00PM - 4:00PM), weekday evening (4:00PM - 6:00PM) and on Saturday February 25, 2023 during the midday (11:00AM - 2:00PM).<sup>1</sup> These periods coincide with the anticipated peak-hour operation times of the proposed use as well as the adjacent street traffic. The observed peak hours were 7:30AM to 8:30AM, 2:30PM to 3:30PM, and 4:15PM to 5:15PM on the weekday, and 1:00PM to 2:00PM on the Saturday. Counts were performed at the following intersections:

- East Market St/Mulberry St
- East Market St/North Parsonage St
- South St/Mulberry St
- South St/North Parsonage St/South Parsonage St

Given their proximity to Rhinebeck school District, East Market Street/North Parsonage Street and South Street/North Parsonage Street/South Parsonage Street intersections were only counted during the weekday morning and weekday dismissal peak hour. These intersections will experience high volumes of passenger vehicles, school buses, and pedestrians during the peak hours.

It is important to note that the Novel Coronavirus/COVID-19 pandemic was anticipated to have an effect on the turning movement counts. CM cited historical traffic data published by the NYSDOT on the Traffic Data Viewer to compare the observed counts on East Market Street and North Parsonage Street intersection. The comparison showed that the observed AM and school dismissal volumes were higher than the historical data. For the weekday evening period, the comparison showed that the volumes were lower than historical data. A calibration factor was calculated and applied to the weekday evening and Saturday volumes to develop “pre-pandemic” traffic volumes.<sup>2</sup> Figure 1-1 shows the 2023 Existing traffic volumes for the study area. The raw TMC data is included under Attachment B.

---

<sup>1</sup> South Street/South Parsonage Street and East Market Street/North Parsonage Street were only counted during the weekday morning and weekday school dismissal periods given their proximity to the school.

<sup>2</sup> Weekday PM Calibration Factor = 1.05 | Saturday Midday Calibration Factor = 1.05

### 3.0 Traffic Assessment

#### Trip Generation

Trip generation determines the quantity of traffic expected to travel to/from a given site. The Institute of Transportation Engineers’ (ITE) *Trip Generation Manual*, 11<sup>th</sup> Edition, is the industry-standard resource used for estimating trip generation for proposed land uses based on data collected at similar uses. Upon review of the *Trip Generation Manual*, Land Use Code (LUC) 210 “Single-Family Detached Housing” and LUC 220 “Multifamily Housing (Low-Rise)” most accurately describe the proposed uses. Table 4 summarizes the trip generation for the weekday AM, weekday school dismissal, weekday PM, and Saturday Midday peak hours.

**Table 4 – Trip Generation Summary for Proposed Use**

Land Use	Independent Variable	Weekday AM Peak Hour			Weekday School Dismissal Peak Hour			Weekday PM Peak Hour			Saturday Midday Peak Hour		
		Enter	Exit	Total	Enter	Exit	Total	Enter	Exit	Total	Enter	Exit	Total
Multifamily Housing (Low-Rise) – LUC 220	9 Units	1	3	4	3	2	5	3	2	5	2	2	4
Single Family Detached House – LUC 210 <sup>1</sup>	4 Unit	0	4	4	4	0	4	4	0	4	0	4	4
<b>Total Trips Generated</b>		<b>1</b>	<b>7</b>	<b>8</b>	<b>7</b>	<b>2</b>	<b>9</b>	<b>7</b>	<b>2</b>	<b>9</b>	<b>2</b>	<b>6</b>	<b>8</b>

<sup>1</sup>A total of four units for this development as is reflected in the total trips generated row.

Table 4 shows that the project is expected to generate eight total trips during weekday AM peak hour, nine total trips during the weekday school dismissal peak hour, nine total trips during the weekday PM peak hour, and eight trips during the Saturday midday peak hour. It is important to note that there is no “pass-by” component of the traffic associated with the proposed development. Additionally, the magnitude of the new traffic associated with this development is less than the NYSDOT and ITE threshold of 100-site generated trips on any one intersection, which is an industry threshold indicating whether a proposed development will have a significant impact on off-site intersections. While the anticipated trip generation falls below that threshold, the study herein analyzes four off-site intersections.

In response to Tighe and Bond’s request for more information about the existing/historic use, CM has noted that the subject site is developed with a three-story building previously occupied by Bulkeley Schoolhouse elementary school in the 20<sup>th</sup> century. The property continues to be used periodically for community and educational purposes including basketball leagues and private educational uses. In order to provide some background on the trip making characteristics of the historical school use, CM had developed a trip generation estimate based on the available information. CM was unable to determine the size of the student body when it was fully operational; therefore, CM applied the trip generation of the *proposed use* during the weekday PM peak hour to calculate the number of students that would result in an equivalent number of vehicle trips. Based on the ITE data for the LUC 520 “Elementary School,” the school would have generated nine total trips during the weekday PM peak hour with 55 students enrolled. Table 5 summarizes the trip generation of the school during the other three peak hours assuming an enrollment of 55 students.

**Table 5 – Trip Generation Summary for Previous Use**

Land Use	Independent Variable	Weekday AM Peak Hour			Weekday School Dismissal Peak Hour			Weekday PM Peak Hour			Saturday Midday Peak Hour		
		Enter	Exit	Total	Enter	Exit	Total	Enter	Exit	Total	Enter	Exit	Total
Elementary School – LUC 520	55 Students	22	19	41	14	11	25	4	5	9	--	--	--



Table 5 shows that the previous use would need to have 55 students to generate nine trips in the PM peak hour of the proposed development. Furthermore, the school would have generated 33 more trips during the weekday AM peak hour and 16 more trips during the weekday school dismissal peak hour. School traffic is generally more concentrated with the majority of trips occurring within a fraction of the peak hour whereas residential traffic is typically distributed over the course of the peak hour.

**Future Traffic Volumes**

To evaluate the impact of the proposed project, traffic projections were prepared for the anticipated year of completion – 2025. Historic traffic volume data along East Market Street indicates that traffic volumes along the roadway have decreased by 1.72% annually.<sup>3</sup> In order to conservatively forecast the 2025 traffic volume, a +0.5% growth rate was applied to the existing traffic volumes and compounded annually for two years. CM contacted the Village of Rhinebeck Planning Board Clerk, who identified developments in the area that when constructed could potentially increase traffic within the study area. Table 6 summarizes the other planned development projects that are considered in this analysis.

**Table 6 – Other Planned Development Projects**

Project	Type	Location	Source of Trip Generation	Trips Generated in Study Area by Projects			
				Weekday AM Peak Hour	Weekday School Dismissal Peak Hour	Weekday PM Peak Hour	Saturday Midday Peak Hour
Locus Hill Development	Residential	Rhinecliff Road	CLP	10	16	11	12
Grasmere House Country Inn 2	Hotel	US Route 9	GPI	16	20	20	23

These volumes were then added to the grown 2025 traffic volumes to represent 2025 No-Build conditions. These 2025 No-Build conditions are shown on Figures 1-2 and represent the expected traffic volumes in 2025 *without* the proposed development.

Traffic generated by the project was distributed on the adjacent roadway network based on existing observed travel patterns in the project area. The proximity of the site to the Taconic State Parkway to the east and New York State Thruway to the west is expected to influence trip-making behavior. The distribution of the multifamily residential and detached family homes is shown on Figures 2A and 2B, respectively. The associated site-generated traffic volumes are shown on Figures 3A for the multifamily residential and Figure 3B for the single-family homes. The site-generated trips were then added to the 2025 No-Build traffic volumes, resulting in the 2025 Build traffic volumes shown on Figure 4.

**Traffic Operations**

Intersection Level of Service (LOS) and capacity analysis relate traffic volumes to the physical characteristics of an intersection. Intersection evaluations were made using Synchro Version 11 software, which automates the procedures contained in the Highway Capacity Manual. Table 7A and Table 7B summarize the results of the level of service calculations for the Existing, No-Build, and Build conditions during the weekday AM peak hour, weekday school dismissal peak hour, weekday PM peak hour, and Saturday Midday peak hour. The detailed level of service analyses are included under Attachment C.

<sup>3</sup> Based on NYSDOT ATR Station ID 820596. Study years: 2013, 2015, 2019.

**Table 7A – Level of Service Summary**

Intersection	Control	Weekday AM Peak Hour			School Dismissal Peak Hour		
		2023 Existing	2025 No-Build	2025 Build	2023 Existing	2025 No-Build	2025 Build
East Market St/Mulberry St	U						
E. Market St, EB LTR		A (7.7)	A (7.7)	A (7.7)	A (7.6)	A (7.6)	A (7.6)
E. Market St, WB LTR		A (7.5)	A (7.5)	A (7.5)	A (7.7)	A (7.8)	A (7.8)
Mulberry St, NB LTR		B (13.0)	B (13.3)	B (13.3)	C (15.0)	C (15.5)	C (15.7)
Mulberry, SB LTR		B (12.4)	B (12.6)	B (12.7)	B (13.7)	B (14.1)	B (14.2)
East Market St/North Parsonage St	U						
E. Market St, EB LTR		A (7.7)	A (7.7)	A (7.7)	A (7.6)	A (7.6)	A (7.6)
E. Market St, WB LTR		A (7.9)	A (7.9)	A (7.9)	A (7.8)	A (7.8)	A (7.8)
N. Parsonage St, SB LTR		B (13.5)	B (13.8)	B (13.8)	B (11.7)	B (11.8)	B (11.8)
Mulberry St/South Street	U						
South St, EB LT		A (7.6)	A (7.7)	A (7.7)	A (7.8)	A (7.9)	A (7.9)
Mulberry St, SB LR		A (9.6)	A (9.8)	A (9.8)	B (10.1)	B (10.3)	B (10.3)
South St/South Parsonage St	U						
South St, EB TR		B (12.5)	B (14.1)	B (14.1)	B (11.5)	B (12.5)	B (12.5)
South St, WB LT		C (23.0)	D (25.2)	D (25.2)	C (16.6)	C (17.2)	C (17.2)
S. Parsonage St, NB LR		A (8.3)	A (8.3)	A (8.3)	A (7.8)	A (7.8)	A (7.8)
S. Parsonage St, SB LTR		A (0)	A (0)	A (7.5)	A (7.5)	A (7.5)	
Mulberry St/Lot 1	U						
Lot 1, EB LR		--	--	A (9.3)	--	--	A (0)
Mulberry St, NB LT		--	--	A (0)	--	--	A (0)
Mulberry St/Lot 2	U						
Lot 2, EB LR		--	--	A (9.3)	--	--	A (0)
Mulberry St, NB LT		--	--	A (0)	--	--	A (0)
Mulberry St/Lot 3	U						
Lot 3, EB LR		--	--	A (9.0)	--	--	A (0)
Mulberry St, NB LT		--	--	A (0)	--	--	A (0)
South St/Lot 4	U						
South St, EB LT		--	--	A (0)	--	--	A (7.4)
Lot 4, SB LR		--	--	A (8.8)	--	--	A (0)
South St/Lot 5	U						
South St, EB LT		--	--	A (0)	--	--	A (7.4)
Lot 5, SB LR		--	--	A (8.8)	--	--	A (0)

U = Unsignalized intersection  
 S = Signalized intersection  
 EB, WB, NB, SB = Eastbound, Westbound, Northbound, and Southbound intersection approaches  
 L, T, R = Left-turn, Through, and/or Right-turn movements  
 X (Y.Y) = Level of service (Average delay in seconds per vehicle)

**Table 7B – Level of Service Summary**

Intersection	Control	Weekday PM Peak Hour			Saturday Midday Peak Hour		
		2023 Existing	2025 No-Build	2025 Build	2023 Existing	2025 No-Build	2025 Build
East Market St/Mulberry St	U						
E. Market St, EB LTR		A (7.7)	A (7.7)	A (7.7)	A (7.6)	A (7.6)	A (7.6)
E. Market St, WB LTR		A (7.5)	A (7.7)	A (7.7)	A (7.7)	A (7.7)	A (7.7)
Mulberry St, NB LTR		B (12.6)	B (13.0)	B (13.2)	B (12.2)	B (12.4)	B (12.4)
Mulberry, SB LTR		B (12.3)	B (12.4)	B (12.5)	B (11.3)	B (11.5)	B (11.5)
Mulberry St/South Street	U						
South St, EB LT		A (7.6)	A (7.4)	A (7.4)	A (7.4)	A (7.4)	A (7.4)
Mulberry St, SB LR		A (9.1)	A (9.6)	A (9.3)	A (9.1)	A (9.3)	A (9.3)
Mulberry St/Lot 1	U						
Lot 1, EB LR		--	--	A (0)	--	--	A (8.8)
Mulberry St, NB LT		--	--	A (0)	--	--	A (0)
Mulberry St/Lot 2	U						
Lot 2, EB LR		--	--	A (0)	--	--	A (8.8)
Mulberry St, NB LT		--	--	A (0)	--	--	A (0)
Mulberry St/Lot 3	U						
Lot 3, EB LR		--	--	A (8.7)	--	--	A (8.8)
Mulberry St, NB LT		--	--	A (7.3)	--	--	A (7.3)
South St/Lot 4	U						
South St, EB LT		--	--	A (7.3)	--	--	A (8.5)
Lot 4, SB LR		--	--	A (0)	--	--	A (0)
South St/Lot 5	U						
South St, EB LT		--	--	A (7.3)	--	--	A (8.5)
Lot 5, SB LR		--	--	A (0)	--	--	A (0)

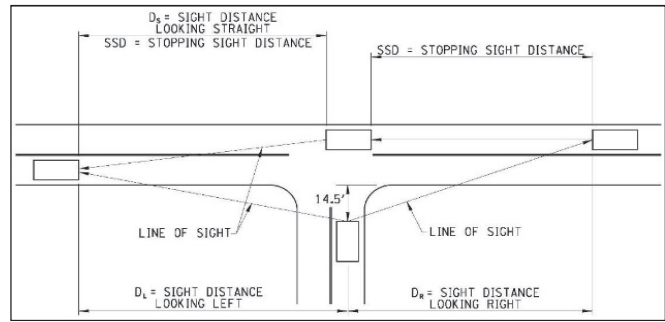
U = Unsignalized intersection  
 S = Signalized intersection  
 EB, WB, NB, SB = Eastbound, Westbound, Northbound, and Southbound intersection approaches  
 L, T, R = Left-turn, Through, and/or Right-turn movements  
 X (Y.Y) = Level of service (Average delay in seconds per vehicle)

The impact of the project can be described by comparing the analysis of the No-Build and Build operating conditions. The following observation are evident from the analysis:

- **East Market Street/Mulberry Street:** The level of service analysis indicates that the eastbound South Main Street approach currently operates at an acceptable LOS B or better during the study peak hours and will continue to do so in the Build conditions.
- **East Market Street/North Parsonage Street:** The level of service analysis indicates that the eastbound South Main Street approach currently operates at an acceptable LOS B or better during the study peak hours and will continue to do so in the Build conditions.
- **Mulberry Street/South Street:** The level of service analysis indicates that the eastbound South Main Street approach currently operates at an acceptable LOS B or better during the study peak hours and will continue to do so in the Build conditions.
- **South Street/South Parsonage Street:** The level of service analysis indicates that the eastbound South Main Street approach currently operates at an acceptable LOS C or better during the study peak hours and will continue to do so in the Build conditions.
- **Site Driveways (Lot 1 – Lot 5):** The level of service analysis indicates that as a two-way stop-controlled intersection with stop-control the driveway approaches will operate at a LOS A during all peak hours.

#### 4.0 Sight Distance

The available intersection sight distance from the site driveway intersections were measured from the perspective of a driver who would be exiting the site and looking in both directions along Mulberry Street to determine if adequate sight lines are available. The intersection sight distance was also measured for drivers traveling north on Mulberry Street seeking to turn left into the proposed site driveway. The available intersection sight distance on a side street or driveway should provide drivers a sufficient view of the intersecting highway to allow vehicles to enter or exit the intersection without excessively slowing vehicles traveling at or near the operating speed on the intersecting mainline. *Stopping* sight distance was also measured at the proposed site driveways. Stopping sight distance is the length of the roadway ahead that is visible to the driver on the mainline. The available stopping sight distance on a roadway should be of sufficient length to enable a vehicle traveling at or near the operating speed to stop before reaching a stationary object in its path. Exhibit 6 depicts the sight distance measurements.



**Exhibit 6 – Sight Distance Measurements**

The posted speed limit on Mulberry Street along the subject site’s frontage is 30 miles per hour. Therefore, the sight distances measured in the field were compared to the guidelines presented in the AASHTO *A Policy on Geometric Design of Highway and Streets* “Green Book”, 2018, and NYSDOT design guidance (EB 17-007) for 35 miles per hour (Posted speed + 5MPH). The results of the analysis are summarized in Table 8.

**Table 8 – Sight Distance Summary**

Intersection		Intersection Sight Distance <sup>1</sup>				Stopping Sight Distance <sup>2</sup>	
		Right Turn from Site Driveway (D <sub>I</sub> )	Left Turn from Site Driveway		Left Turn from Mulberry Street (D <sub>S</sub> )	SSD <sub>NB</sub>	SSD <sub>SB</sub>
			Looking Left (D <sub>L</sub> )	Looking Right (D <sub>R</sub> )			
Mulberry Street/Site Driveway	Available	218 ft	218 ft	202 ft	202 ft	177 ft	218 ft
	Recommended	335 ft	390 ft	390 ft	285 ft	250 ft	250 ft

<sup>1</sup>Intersection sight distance is measured 14.5 feet back from the traveled way at an object height of 3.5 feet and an eye height of 3.5 feet for a vehicle.

<sup>2</sup>Stopping sight distance is measured from an eye height of 3.5 feet for a passenger car to an object height of 2 feet located in the path of northbound and southbound vehicles.

The sight distance evaluation for the site driveway serving the parking lot of the multi-family residential building indicates that the available intersection and stopping sight distances do not meet the AASHTO recommended guidelines for an assumed operating speed of 35 miles per hour. It should be noted that the evaluation is based on a conservative operating speed of 35 miles per hour. A more realistic speed is the actual posted speed limit of 30 miles per hour given that each intersection operates under stop-control, which requires vehicles to fully stop before proceeding north or south along Mulberry Street. The AASHTO recommended stopping sight distance for 30 miles per hour is 175-ft, which would be exceeded based on the location of the proposed driveway. Additionally, assuming that the typical right turn is performed at 10 miles per hour or less, an intersection sight distance of 100 feet should be provided based on “Case B2, Right Turn From Stop” and Equation 9-1 from AASHTO’s *A Policy on Geometric Design of Highways and Streets*, 2018. Assuming that the typical left turn is performed at 15 miles per hour or less, an intersection sight distance of 145 feet should be provided based on the same methodology. Lastly, the driveway location exceeds the NYSDOT guidance in its *Policy and Standard for Design of Entrances to State Highways* for driveway offset from adjacent intersections.

## 5.0 Site Access, Circulation, and Parking

CM reviewed the site access, site circulation, and parking as shown on the Proposed Subdivision Plan prepared by NAVA Partners LLC. Lots 1, 2 and 3 will be accessed via driveways on Mulberry Street, Lots 4 and 5 will be accessed via driveways on South Street. Each individual lot will have their own driveway. The multi-family building on Lot 3 will be supported by 18 parking spaces inclusive of two ADA-accessible spaces. The proposed number of parking spaces meets the Village of Rhinebeck zoning requirements.<sup>4</sup>

## 6.0 Conclusion

The subject site is defined on the Dutchess County Tax Map as Section 19, Block 1, Lot 10. The proposed project consists of redeveloping the existing building into a multi-family residential building and four single-family residential homes on adjacent lots. Two of the single-family homes and the multi-family residential building will be accessed via individual driveways on Mulberry Street and the two other single-family homes will be accessed via individual driveways on South Street. The following is noted regarding the proposed project:

- Turning movement counts were collected during a typical weekday and typical Saturday at the study intersections.
- Upon review of the *Trip Generation Manual*, Land Use Code (LUC) 210 "Single Family Detached Home" and LUC 220 "Multifamily Housing (Low-Rise)" most closely described the anticipated uses on site.
- The development is expected to generate a total of eight trips during the AM peak hour, a total of nine trips during the school dismissal peak hour, a total of nine trips during the PM peak hour, and a total of eight trips during the Saturday midday peak hour.
- Two other developments were identified by the Village of Rhinebeck and the traffic generated was included in this analysis.
- The level of service analysis indicates that the Build condition of the study intersections will operate at the levels of service consistent with the No-Build conditions.
- The project is not expected to have a significant adverse impact on surrounding roadway network.

Please do not hesitate to call our office if you have any questions or comments, or require additional information.

Respectfully submitted,  
**Creighton Manning Engineering, LLP**



Frank A. Filiciotto, PE  
Associate



Fior M. Perez, EIT  
Assistant Project Engineer

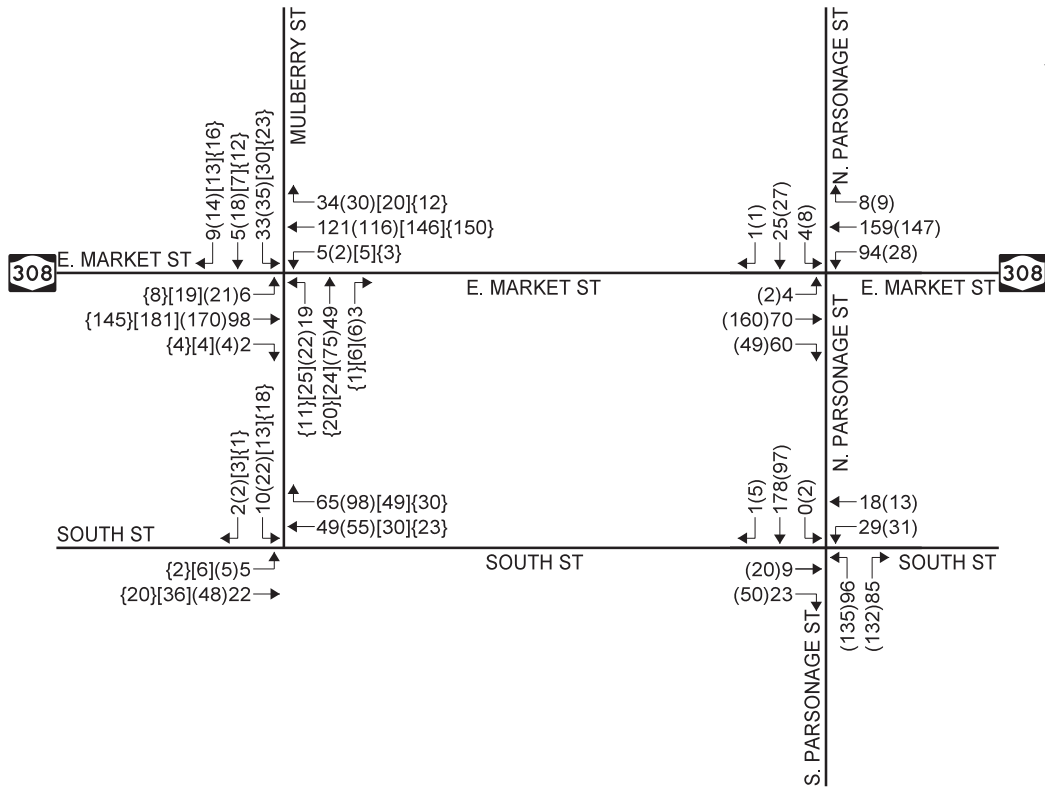
cc:

---

<sup>4</sup> Dwelling, Multifamily – 9 units \* 2 spaces/units = 18 spaces | Total Required = 18

①

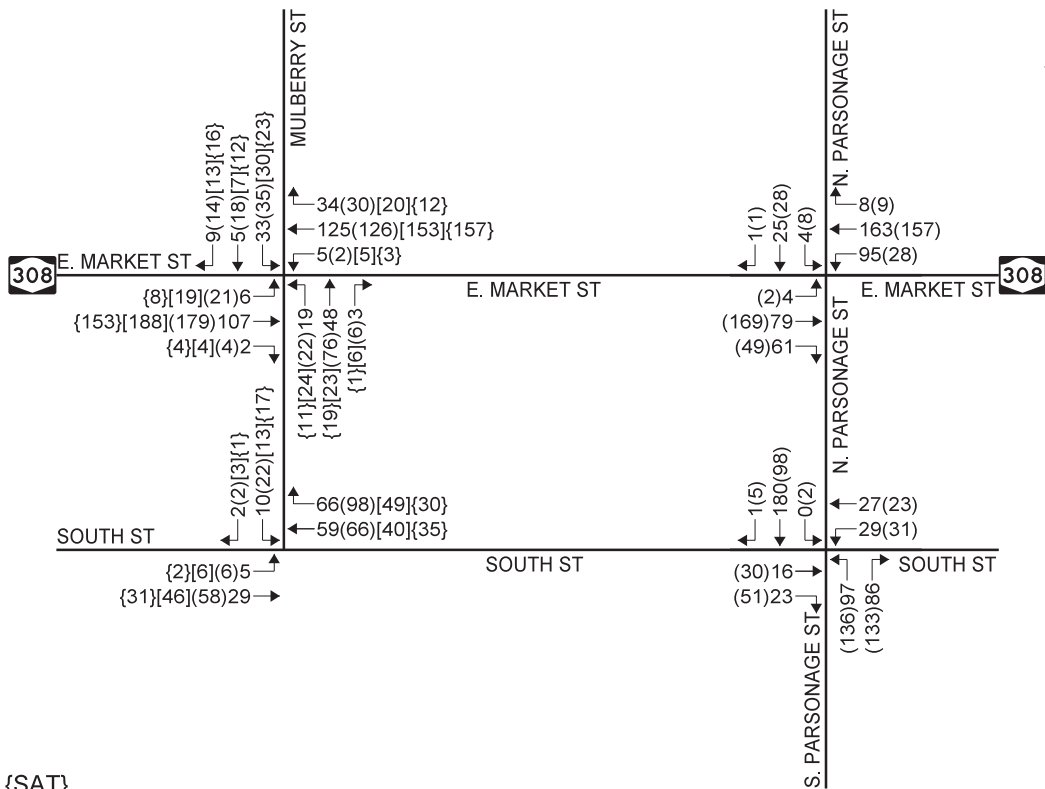
### 2023 EXISTING TRAFFIC VOLUMES



AM (MIDDAY) [PM] {SAT}

②

### 2025 NO-BUILD TRAFFIC VOLUMES



AM (MIDDAY) [PM] {SAT}

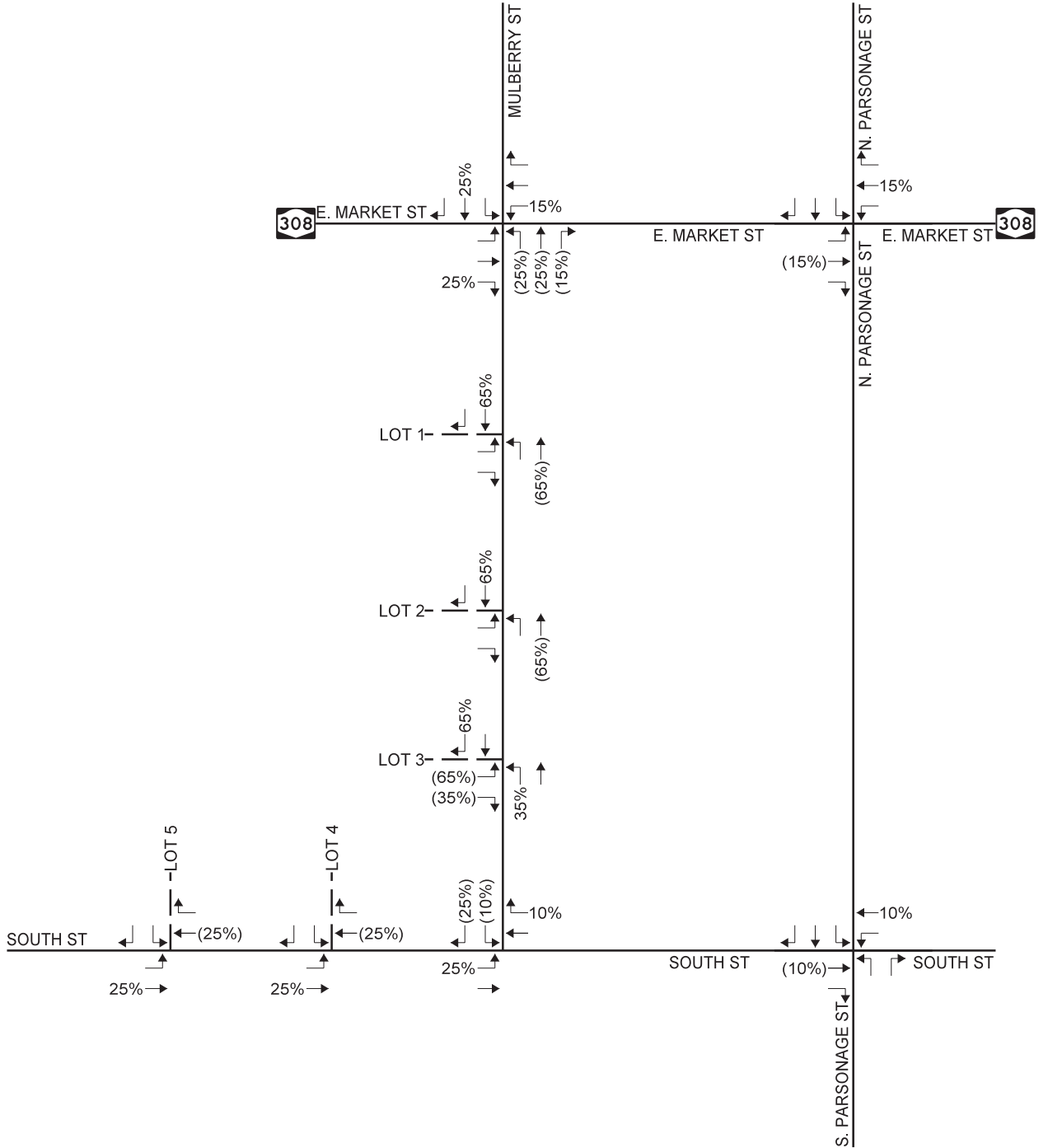
2022 EXISTING & 2025 NO-BUILD TRAFFIC VOLUMES

DUTCHESS SHEPHARD LLC  
VILLAGE OF RHINEBECK  
DUTCHESS COUNTY, NEW YORK



MULTIFAMILY RESIDENTIAL

①



ENTER (EXIT)

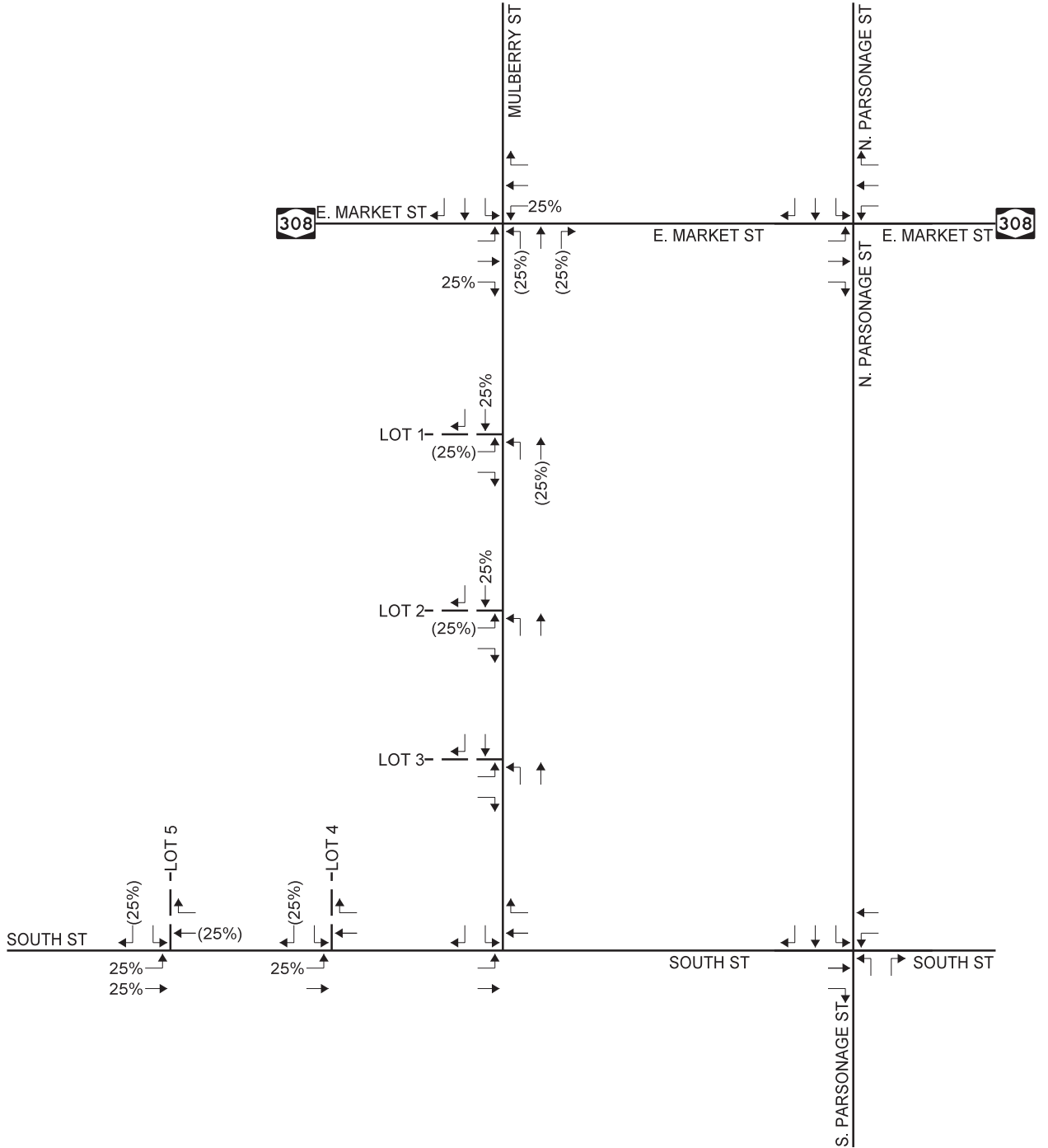
TRIP DISTRIBUTION

DUTCHESS SHEPHARD LLC  
 VILLAGE OF RHINEBECK  
 DUTCHESS COUNTY, NEW YORK



DETACHED FAMILY HOMES

①



ENTER (EXIT)

TRIP DISTRIBUTION

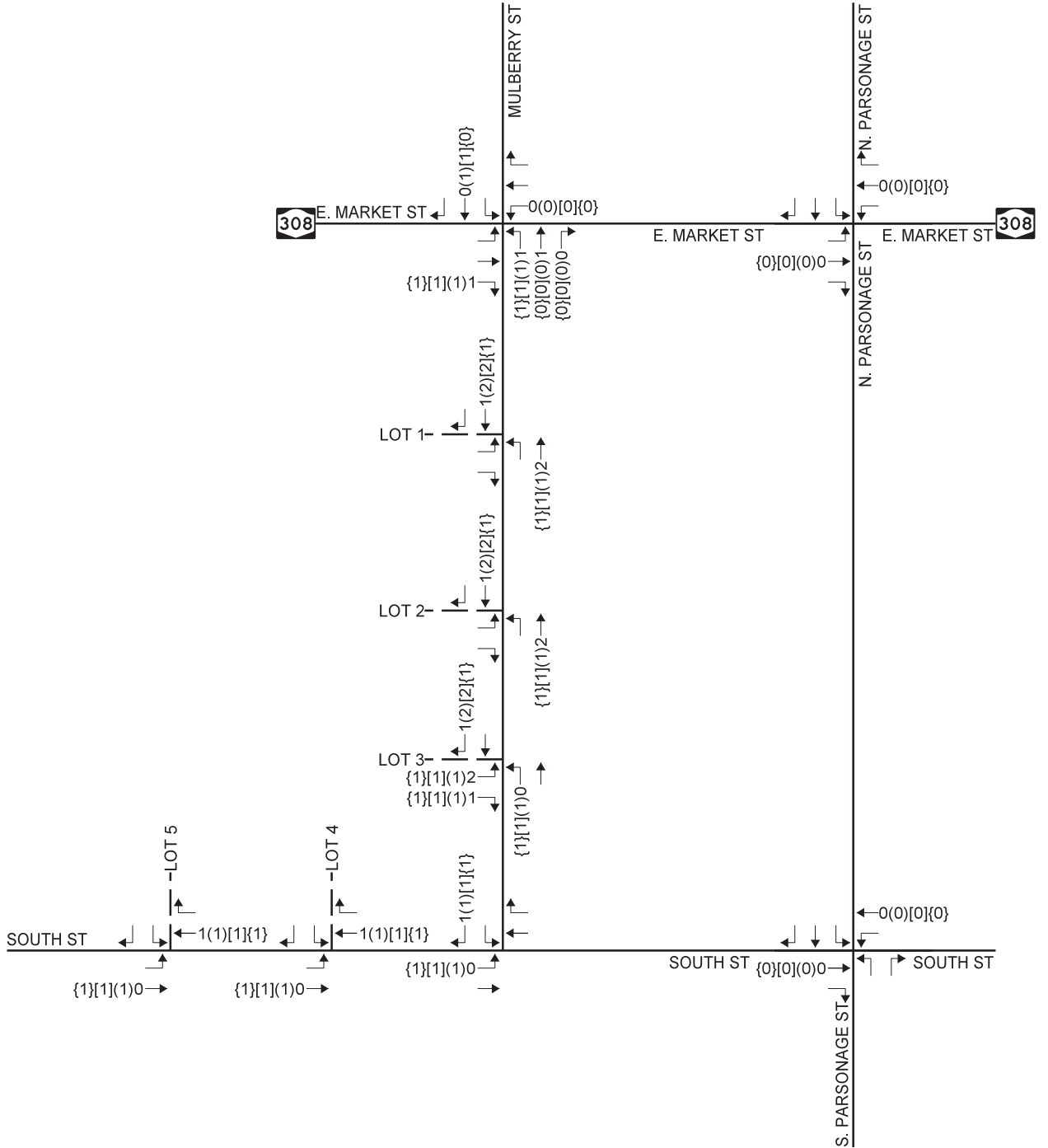
DUTCHESS SHEPARD LLC  
 VILLAGE OF RHINEBECK  
 DUTCHESS COUNTY, NEW YORK





MULTIFAMILY RESIDENTIAL

①



AM (MIDDAY) [PM] {SAT}

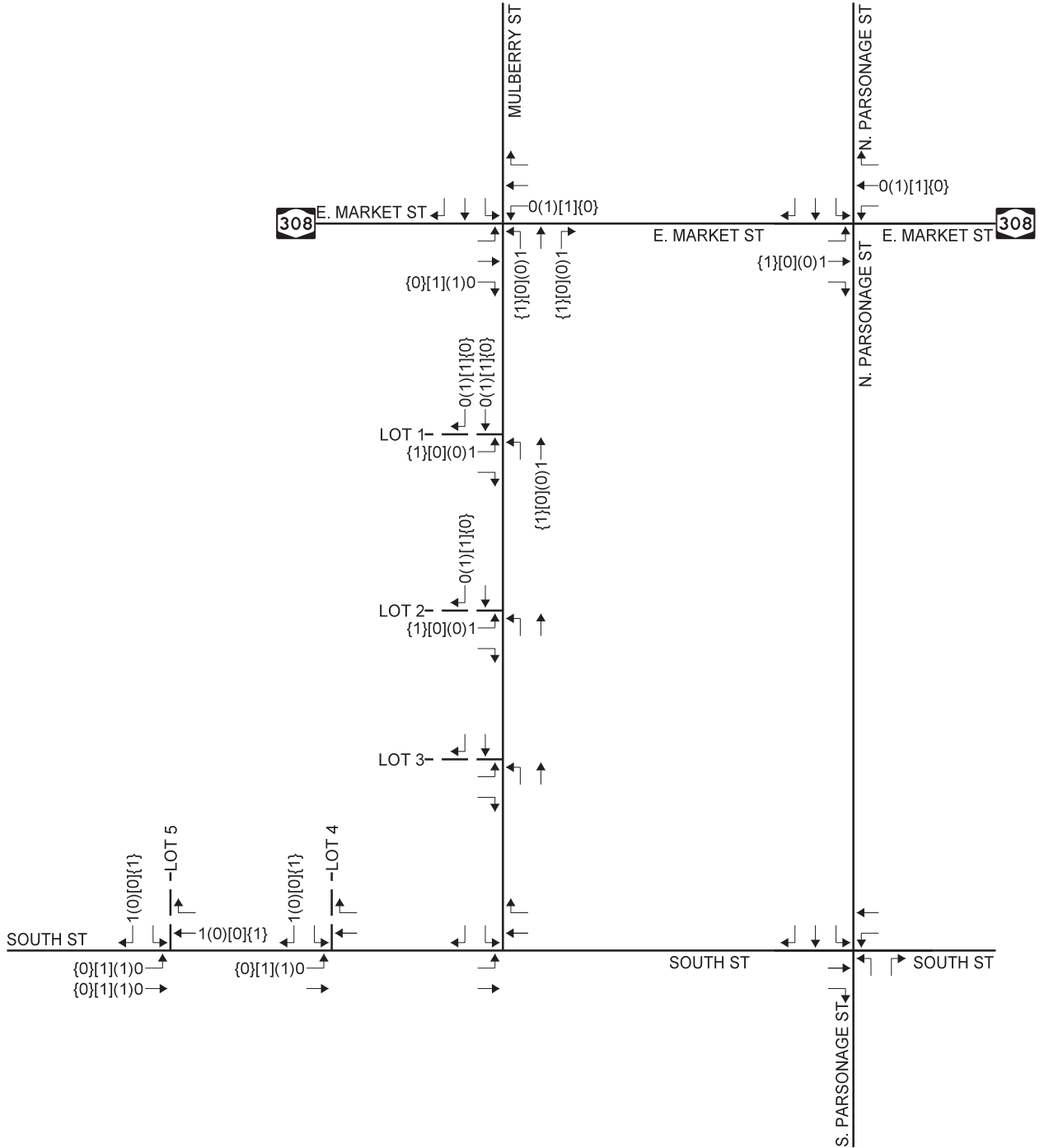
TRIP ASSIGNMENT

DUTCHESS SHEPARD LLC  
 VILLAGE OF RHINEBECK  
 DUTCHESS COUNTY, NEW YORK



DETACHED FAMILY HOMES

①



AM (MIDDAY) [PM] {SAT}

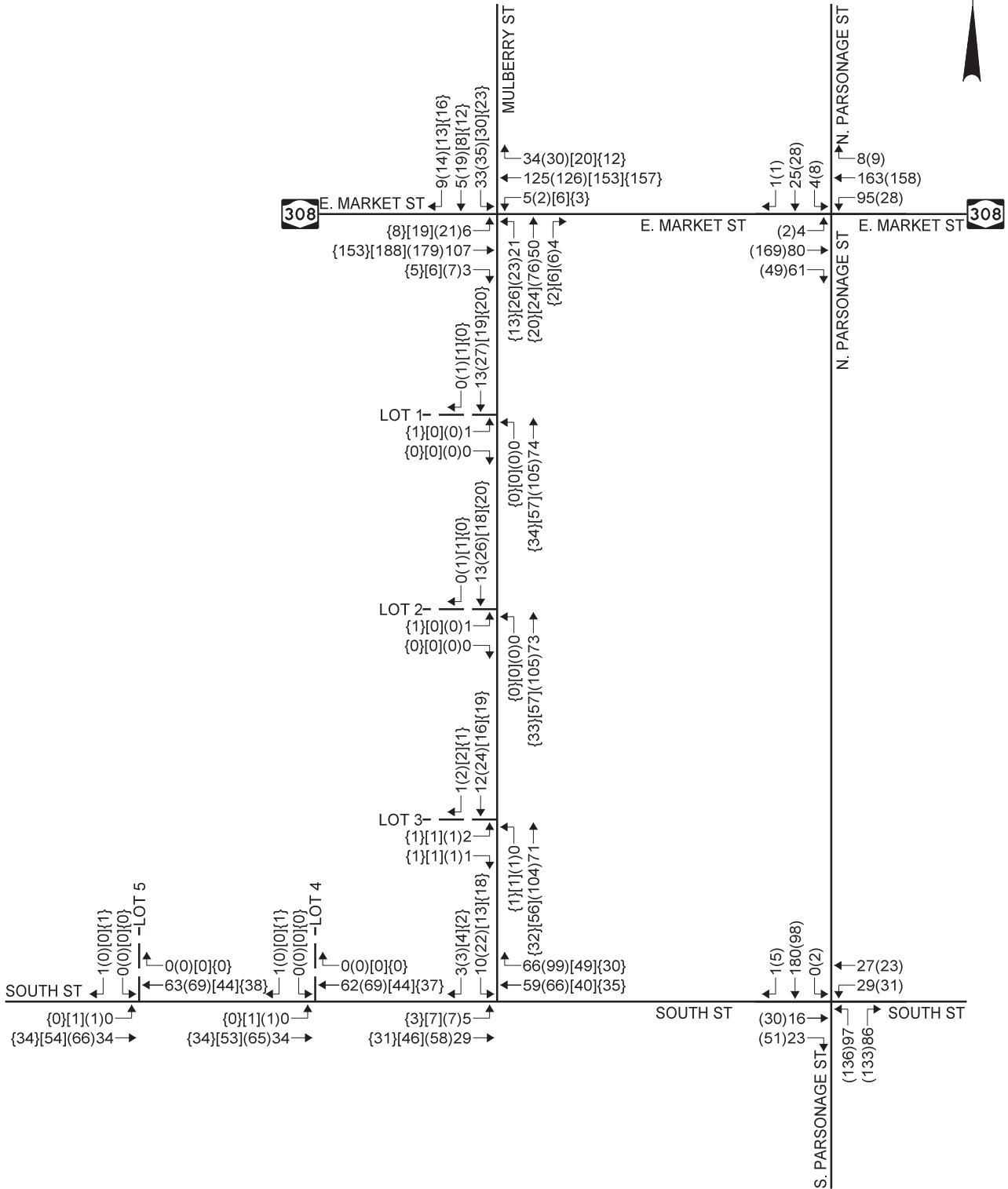
TRIP ASSIGNMENT

DUTCHESS SHEPARD LLC  
 VILLAGE OF RHINEBECK  
 DUTCHESS COUNTY, NEW YORK



DETACHED FAMILY HOMES

①



AM (MIDDAY) [PM] {SAT}

2025 BUILD TRAFFIC VOLUMES

DUTCHESS SHEPARD LLC  
VILLAGE OF RHINEBECK  
DUTCHESS COUNTY, NEW YORK

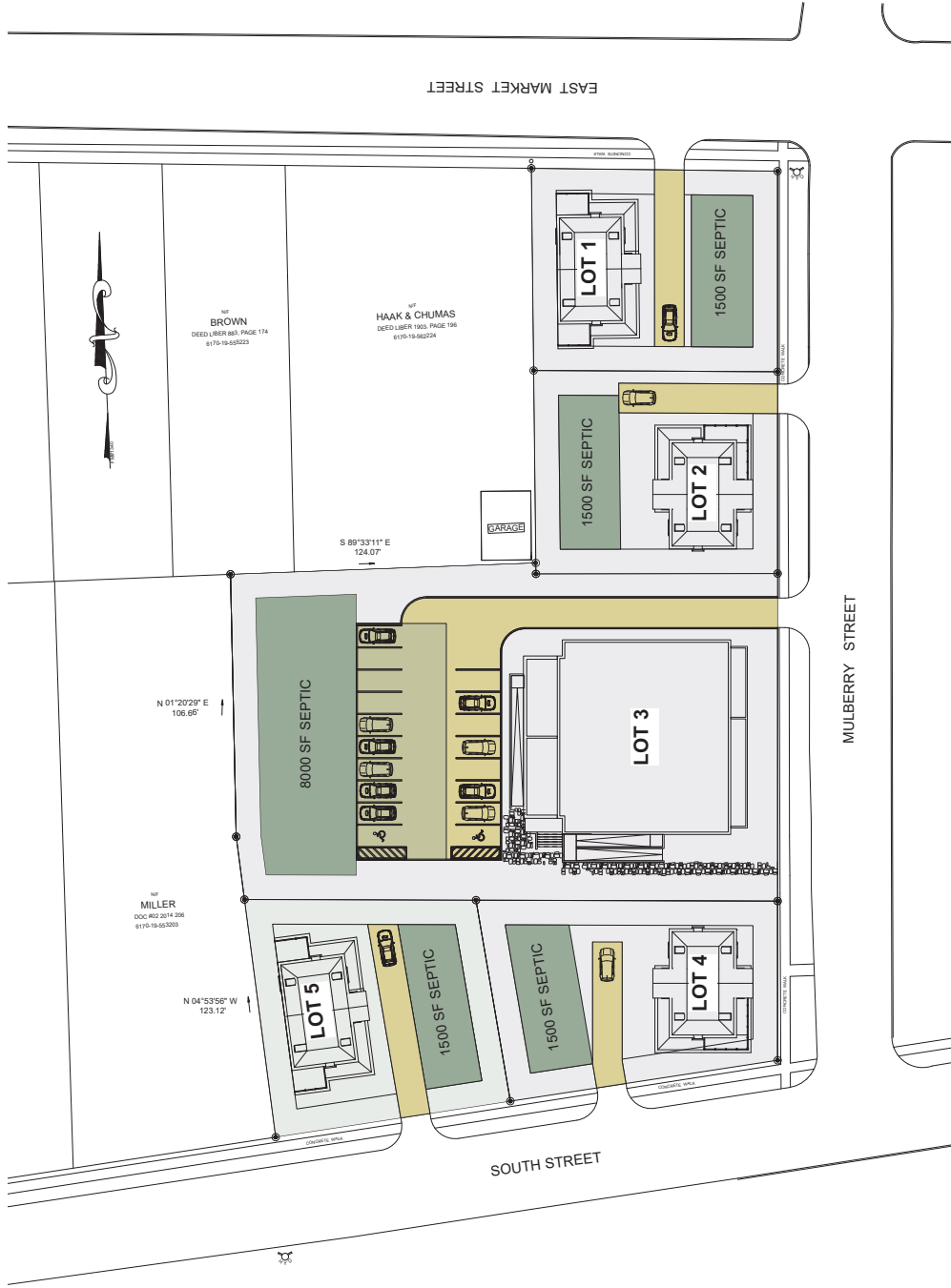


**ATTACHMENT A  
SUBDIVISION PLAN**

6 Mulberry Street  
Village of Rhinebeck  
Dutchess County, New York

**BULKELEY SCHOOLHOUSE OVERLAY DISTRICT**

**PROPOSED SUBDIVISION PLAN**



KEY PLAN

BUILDING AND ZONING TABLE

<p><b>OWNER</b>  <b>DUTCHESS SHEPHERD LLC</b>          333 Cedar Heights Road          Rhinebeck, NY 12572</p>	<p><b>MUNICIPALITY</b>  <b>VILLAGE OF RHINEBECK</b>          Dutchess County, New York</p>	<p><b>REVIEWING AGENCY</b>  <b>PLANNING &amp; ZONING</b>          Rhinebeck, Dutchess County, New York</p>	<p><b>ARCHITECT</b>  <b>NAVA</b>          8</p>
<p><b>Signature:</b>  <b>Print Name:</b></p>	<p><b>Signature:</b>  <b>Print Name:</b></p>	<p><b>Signature:</b>  <b>Print Name:</b></p>	<p><b>Signature:</b>  <b>Print Name:</b></p>

**ATTACHMENT B**  
**TURNING MOVEMENT COUNTS**

6 Mulberry Street  
Village of Rhinebeck  
Dutchess County, New York

# South Street-Mulberry Street Weekday AM - TMC

Wed Mar 1, 2023

Full Length (7 AM-9 AM)

All Classes (Lights, Articulated Trucks and Single-Unit Trucks, Buses, Pedestrians, Bicycles on Road, Bicycles on Crosswalk)

All Movements

ID: 1042879, Location: 41.926015, -73.907341



Provided by: Creighton Manning  
Engineering, LLP  
2 Winners Circle,  
Albany, NY, 12205, US

Leg Direction	South St Eastbound					South St Westbound					Mulberry St Southbound						
Time	L	T	U	App	Ped*	T	R	U	App	Ped*	L	R	U	App	Ped*	Int	
2023-03-01 7:00AM	0	2	0	2	0	3	2	0	5	0	0	0	0	0	0	0	7
7:15AM	1	1	0	2	0	2	2	0	4	0	3	0	0	3	1	9	
7:30AM	0	8	0	8	0	17	12	0	29	0	1	0	0	1	0	38	
7:45AM	3	4	0	7	0	14	38	0	52	0	4	1	0	5	0	64	
Hourly Total	4	15	0	19	0	36	54	0	90	0	8	1	0	9	1	118	
8:00AM	2	5	0	7	0	12	10	0	22	1	1	0	0	1	1	30	
8:15AM	0	5	0	5	0	6	5	0	11	0	1	0	0	1	0	17	
8:30AM	0	11	0	11	0	5	9	0	14	0	2	1	0	3	0	28	
8:45AM	1	4	0	5	0	13	26	0	39	0	2	0	0	2	2	46	
Hourly Total	3	25	0	28	0	36	50	0	86	1	6	1	0	7	3	121	
<b>Total</b>	7	40	0	47	0	72	104	0	176	1	14	2	0	16	4	239	
<b>% Approach</b>	14.9%	85.1%	0%	-	-	40.9%	59.1%	0%	-	-	87.5%	12.5%	0%	-	-	-	
<b>% Total</b>	2.9%	16.7%	0%	19.7%	-	30.1%	43.5%	0%	73.6%	-	5.9%	0.8%	0%	6.7%	-	-	
<b>Lights</b>	7	38	0	45	-	70	99	0	169	-	14	2	0	16	-	230	
<b>% Lights</b>	100%	95.0%	0%	95.7%	-	97.2%	95.2%	0%	96.0%	-	100%	100%	0%	100%	-	96.2%	
<b>Articulated Trucks and Single-Unit Trucks</b>	0	1	0	1	-	0	1	0	1	-	0	0	0	0	-	2	
<b>% Articulated Trucks and Single-Unit Trucks</b>	0%	2.5%	0%	2.1%	-	0%	1.0%	0%	0.6%	-	0%	0%	0%	0%	-	0.8%	
<b>Buses</b>	0	1	0	1	-	2	4	0	6	-	0	0	0	0	-	7	
<b>% Buses</b>	0%	2.5%	0%	2.1%	-	2.8%	3.8%	0%	3.4%	-	0%	0%	0%	0%	-	2.9%	
<b>Bicycles on Road</b>	0	0	0	0	-	0	0	0	0	-	0	0	0	0	-	0	
<b>% Bicycles on Road</b>	0%	0%	0%	0%	-	0%	0%	0%	0%	-	0%	0%	0%	0%	-	0%	
<b>Pedestrians</b>	-	-	-	-	0	-	-	-	-	0	-	-	-	-	-	4	
<b>% Pedestrians</b>	-	-	-	-	-	-	-	-	-	0%	-	-	-	-	100%	-	
<b>Bicycles on Crosswalk</b>	-	-	-	-	0	-	-	-	-	1	-	-	-	-	-	0	
<b>% Bicycles on Crosswalk</b>	-	-	-	-	-	-	-	-	-	100%	-	-	-	-	0%	-	

\*Pedestrians and Bicycles on Crosswalk. L: Left, R: Right, T: Thru, U: U-Turn

South Street-Mulberry Street Weekday AM - TMC

Wed Mar 1, 2023

Full Length (7 AM-9 AM)

All Classes (Lights, Articulated Trucks and Single-Unit Trucks, Buses, Pedestrians, Bicycles on Road, Bicycles on Crosswalk)

All Movements

ID: 1042879, Location: 41.926015, -73.907341

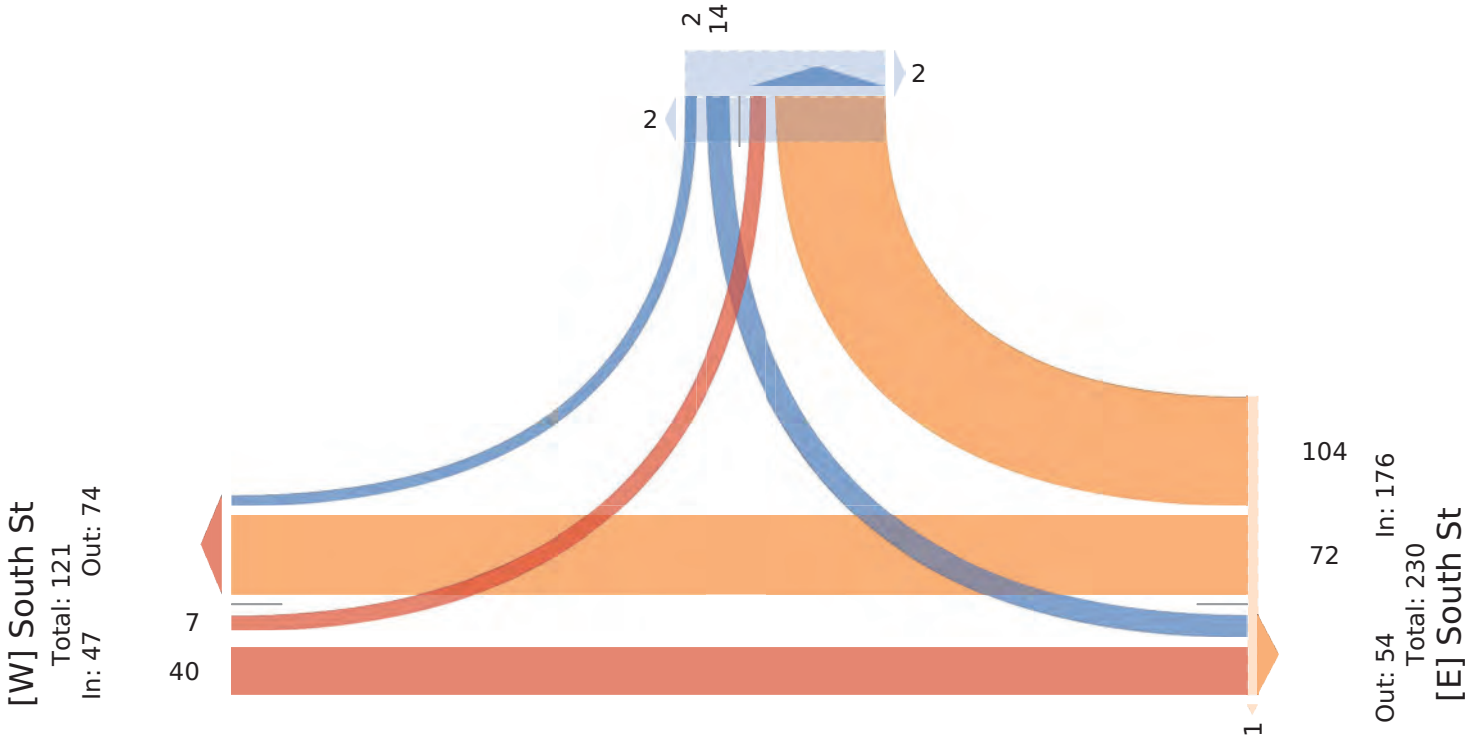


Provided by: Creighton Manning  
Engineering, LLP  
2 Winners Circle,  
Albany, NY, 12205, US

[N] Mulberry St

Total: 127

In: 16 Out: 111





South Street-Mulberry Street Weekday AM - TMC

Wed Mar 1, 2023

AM Peak (7:30 AM - 8:30 AM) - Overall Peak Hour

All Classes (Lights, Articulated Trucks and Single-Unit Trucks, Buses, Pedestrians, Bicycles on Road, Bicycles on Crosswalk)

All Movements

ID: 1042879, Location: 41.926015, -73.907341



Provided by: Creighton Manning Engineering, LLP  
2 Winners Circle,  
Albany, NY, 12205, US

Leg Direction	South St Eastbound					South St Westbound					Mulberry St Southbound					Int
	L	T	U	App	Ped*	T	R	U	App	Ped*	L	R	U	App	Ped*	
2023-03-01 7:30AM	0	8	0	8	0	17	12	0	29	0	1	0	0	1	0	38
7:45AM	3	4	0	7	0	14	38	0	52	0	4	1	0	5	0	64
8:00AM	2	5	0	7	0	12	10	0	22	1	1	0	0	1	1	30
8:15AM	0	5	0	5	0	6	5	0	11	0	1	0	0	1	0	17
<b>Total</b>	5	22	0	27	0	49	65	0	114	1	7	1	0	8	1	149
<b>% Approach</b>	18.5%	81.5%	0%	-	-	43.0%	57.0%	0%	-	-	87.5%	12.5%	0%	-	-	-
<b>% Total</b>	3.4%	14.8%	0%	18.1%	-	32.9%	43.6%	0%	76.5%	-	4.7%	0.7%	0%	5.4%	-	-
<b>PHF</b>	0.417	0.688	-	0.844	-	0.721	0.428	-	0.548	-	0.438	0.250	-	0.400	-	0.582
<b>Lights</b>	5	21	0	26	-	48	60	0	108	-	7	1	0	8	-	142
<b>% Lights</b>	100%	95.5%	0%	96.3%	-	98.0%	92.3%	0%	94.7%	-	100%	100%	0%	100%	-	95.3%
<b>Articulated Trucks and Single-Unit Trucks</b>	0	1	0	1	-	0	1	0	1	-	0	0	0	0	-	2
<b>% Articulated Trucks and Single-Unit Trucks</b>	0%	4.5%	0%	3.7%	-	0%	1.5%	0%	0.9%	-	0%	0%	0%	0%	-	1.3%
<b>Buses</b>	0	0	0	0	-	1	4	0	5	-	0	0	0	0	-	5
<b>% Buses</b>	0%	0%	0%	0%	-	2.0%	6.2%	0%	4.4%	-	0%	0%	0%	0%	-	3.4%
<b>Bicycles on Road</b>	0	0	0	0	-	0	0	0	0	-	0	0	0	0	-	0
<b>% Bicycles on Road</b>	0%	0%	0%	0%	-	0%	0%	0%	0%	-	0%	0%	0%	0%	-	0%
<b>Pedestrians</b>	-	-	-	-	0	-	-	-	-	0	-	-	-	-	-	1
<b>% Pedestrians</b>	-	-	-	-	-	-	-	-	-	0%	-	-	-	-	-	100%
<b>Bicycles on Crosswalk</b>	-	-	-	-	0	-	-	-	-	1	-	-	-	-	-	0
<b>% Bicycles on Crosswalk</b>	-	-	-	-	-	-	-	-	-	100%	-	-	-	-	-	0%

\* Pedestrians and Bicycles on Crosswalk. L: Left, R: Right, T: Thru, U: U-Turn

South Street-Mulberry Street Weekday AM - TMC

Wed Mar 1, 2023

AM Peak (7:30 AM - 8:30 AM) - Overall Peak Hour

All Classes (Lights, Articulated Trucks and Single-Unit Trucks, Buses, Pedestrians, Bicycles on Road, Bicycles on Crosswalk)

All Movements

ID: 1042879, Location: 41.926015, -73.907341



Provided by: Creighton Manning  
Engineering, LLP  
2 Winners Circle,  
Albany, NY, 12205, US

[N] Mulberry St

Total: 78

In: 8 Out: 70



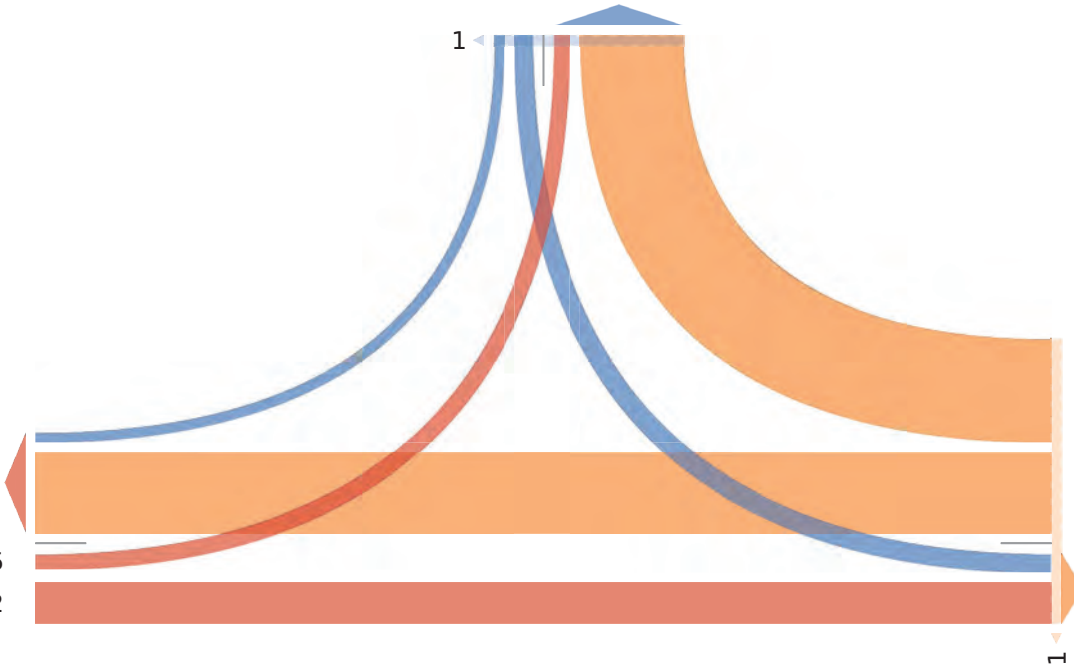
1

[W] South St

Total: 77

In: 27 Out: 50

5  
22



65  
49

Out: 29 In: 114

Total: 143

[E] South St

East Market Street-N Parsonage Street Weekda... - TMC

Wed Mar 1, 2023

Full Length (7 AM-9 AM)

All Classes (Lights, Articulated Trucks and Single-Unit Trucks, Buses, Pedestrians, Bicycles on Road, Bicycles on Crosswalk)

All Movements

ID: 1042889, Location: 41.927228, -73.90652



Provided by: Creighton Manning Engineering, LLP  
2 Winners Circle,  
Albany, NY, 12206, US

Leg Direction	East Market St Eastbound						East Market St Westbound						N Parsonage St Northbound		N Parsonage St Southbound						Int
	L	T	R	U	App	Ped*	L	T	R	U	App	Ped*	App	Ped*	L	T	R	U	App	Ped*	
2023-03-01 7:00AM	0	18	7	0	26	0	10	20	1	0	31	0	0	0	1	2	0	0	3	0	69
7:16AM	1	12	9	0	22	0	18	31	1	0	60	0	0	0	0	2	0	0	2	3	74
7:30AM	0	13	23	0	35	0	44	35	2	0	82	2	0	0	1	11	0	0	12	0	130
7:46AM	4	18	24	0	45	0	33	45	4	0	83	1	0	0	1	9	0	0	10	1	139
Hourly Total	6	51	53	0	129	0	106	133	8	0	245	3	0	0	3	24	0	0	27	4	402
8:00AM	0	19	6	0	24	0	10	38	0	0	48	0	0	0	2	2	1	0	6	0	77
8:16AM	0	19	7	0	25	0	7	39	2	0	48	0	0	0	0	3	0	0	3	1	77
8:30AM	0	16	13	0	28	1	12	28	2	0	42	0	0	0	2	7	0	0	9	0	79
8:46AM	2	24	13	0	39	0	10	49	4	0	53	0	0	0	2	4	2	0	8	0	110
Hourly Total	2	77	38	0	117	1	39	164	8	0	201	0	0	0	5	15	3	0	26	1	343
9:00AM	0	0	0	0	0	0	0	0	0	0	0	0	0	0	0	0	0	0	0	0	0
Hourly Total	0	0	0	0	0	0	0	0	0	0	0	0	0	0	0	0	0	0	0	0	0
<b>Total</b>	7	138	101	0	245	1	144	287	15	0	447	3	0	0	9	40	3	0	62	6	746
<b>% Approach</b>	2.8%	65.1%	41.1%	0%	-	-	32.2%	54.2%	3.5%	0%	-	-	-	-	17.3%	75.9%	6.8%	0%	-	-	-
<b>% Total</b>	0.9%	18.6%	13.5%	0%	33.0%	-	19.3%	38.6%	2.1%	0%	50.0%	-	0%	-	1.2%	6.4%	0.4%	0%	7.0%	-	-
<b>Lights</b>	7	131	97	0	236	-	134	280	15	0	430	-	0	-	9	35	3	0	48	-	713
<b>% Lights</b>	100%	94.9%	95.0%	0%	96.6%	-	93.1%	97.5%	100%	0%	95.2%	-	-	-	100%	90.0%	100%	0%	92.3%	-	96.7%
<b>Articulated Trucks and Single-Unit Trucks</b>	0	7	0	0	7	-	0	5	0	0	5	-	0	-	0	1	0	0	1	-	14
<b>% Articulated Trucks and Single-Unit Trucks</b>	0%	6.1%	0%	0%	2.8%	-	0%	2.1%	0%	0%	1.3%	-	-	-	0%	2.6%	0%	0%	1.9%	-	1.9%
<b>Buses</b>	0	0	4	0	4	-	10	0	0	0	10	-	0	-	0	1	0	0	1	-	16
<b>% Buses</b>	0%	0%	4.0%	0%	1.5%	-	5.9%	0%	0%	0%	2.2%	-	-	-	0%	2.6%	0%	0%	1.9%	-	2.0%
<b>Bicycles on Road</b>	0	0	0	0	0	-	0	1	0	0	1	-	0	-	0	2	0	0	2	-	3
<b>% Bicycles on Road</b>	0%	0%	0%	0%	0%	-	0%	0.3%	0%	0%	0.2%	-	-	-	0%	6.0%	0%	0%	3.8%	-	0.4%
<b>Pedestrians</b>	-	-	-	-	-	1	-	-	-	-	-	3	-	0	-	-	-	-	-	6	
<b>% Pedestrians</b>	-	-	-	-	-	100%	-	-	-	-	-	100%	-	-	-	-	-	-	-	100%	-
<b>Bicycles on Crosswalk</b>	-	-	-	-	-	0	-	-	-	-	-	0	-	0	-	-	-	-	-	0	
<b>% Bicycles on Crosswalk</b>	-	-	-	-	-	0%	-	-	-	-	-	0%	-	-	-	-	-	-	-	0%	-

\* Pedestrians and Bicycles on Crosswalk. L: Left, R: Right, T: Thru, U: U-Turn

East Market Street-N Parsonage Street Weekda... - TMC

Wed Mar 1, 2023

Full Length (7 AM-9 AM)

All Classes (Lights, Articulated Trucks and Single-Unit Trucks, Buses, Pedestrians, Bicycles on Road, Bicycles on Crosswalk)

All Movements

ID: 1042889, Location: 41.927228, -73.90652



Provided by: Creighton Manning Engineering, LLP  
2 Winners Circle,  
Albany, NY, 12206, US

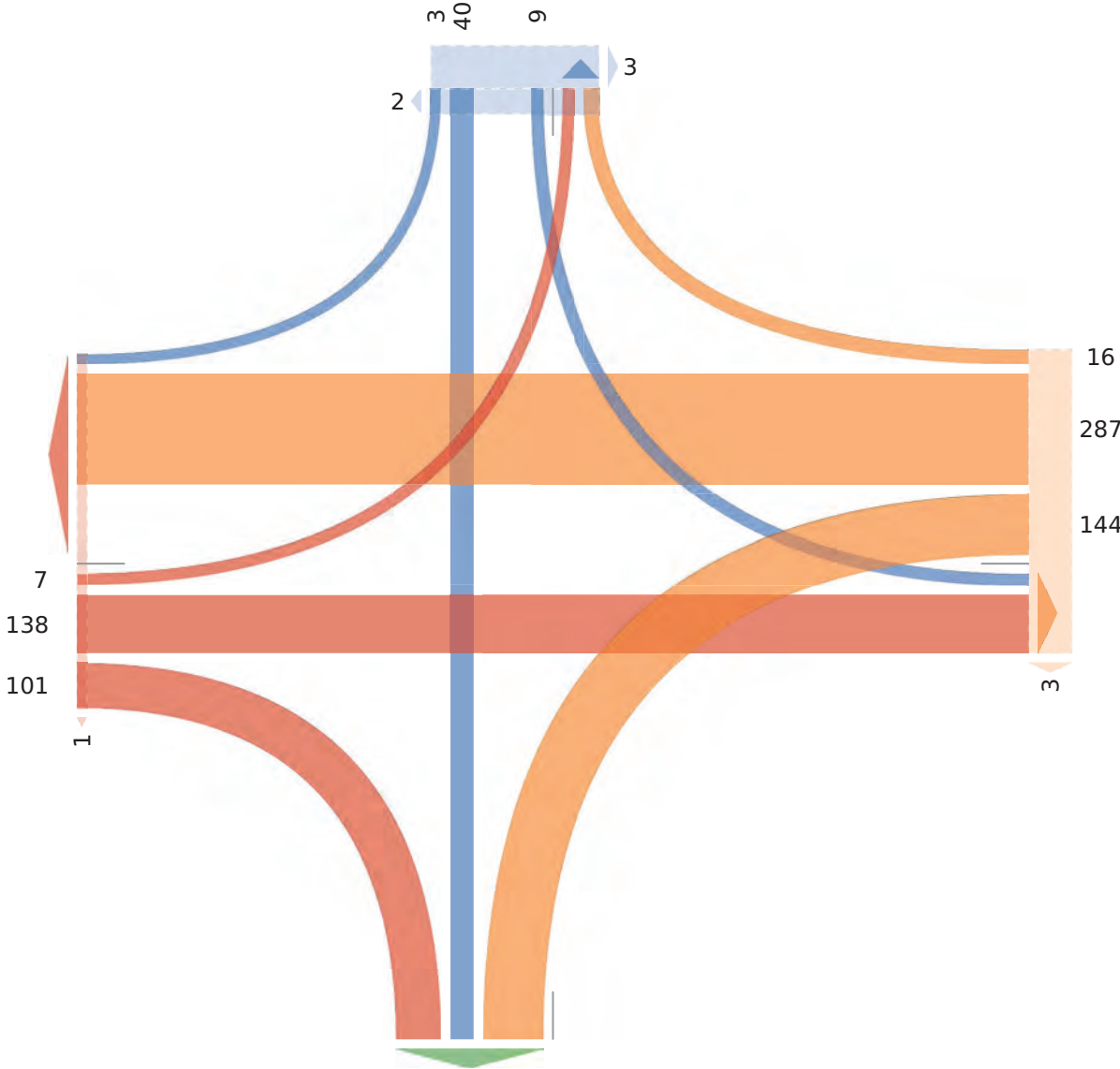
[N] N Parsonage St

Total: 75

In: 52 Out: 23

[W] East Market St

Total: 536  
In: 246 Out: 290



Out: 147 In: 447  
Total: 594

[E] East Market St

Out: 285 In: 0  
Total: 285

[S] N Parsonage St

East Market Street-N Parsonage Street Weekda... - TMC

Wed Mar 1, 2023

AM Peak (7:30 AM - 8:30 AM) - Overall Peak Hour

All Classes (Lights, Articulated Trucks and Single-Unit Trucks, Buses, Pedestrians, Bicycles on Road, Bicycles on Crosswalk)

All Movements

ID: 1042889, Location: 41.927228, -73.90652



Provided by: Creighton Manning Engineering, LLP  
2 Winners Circle,  
Albany, NY, 12206, US

Leg Direction	East Market St Eastbound						East Market St Westbound						N Parsonage St Northbound		N Parsonage St Southbound						Int
	L	T	R	U	App	Ped*	L	T	R	U	App	Ped*	App	Ped*	L	T	R	U	App	Ped*	
2023-03-01 7:30AM	0	13	23	0	35	0	44	35	2	0	82	2	0	0	1	11	0	0	12	0	130
7:46AM	4	18	24	0	45	0	33	45	4	0	83	1	0	0	1	9	0	0	10	1	139
8:00AM	0	19	6	0	24	0	10	38	0	0	48	0	0	0	2	2	1	0	6	0	77
8:16AM	0	19	7	0	25	0	7	39	2	0	48	0	0	0	0	3	0	0	3	1	77
<b>Total</b>	4	59	69	0	132	0	94	169	8	0	251	3	0	0	4	26	1	0	30	2	423
<b>% Approach</b>	3.0%	62.3%	44.7%	0%	-	-	35.0%	50.9%	3.1%	0%	-	-	-	-	13.3%	83.3%	3.3%	0%	-	-	-
<b>% Total</b>	0.9%	15.3%	13.9%	0%	31.2%	-	22.2%	37.5%	1.9%	0%	51.7%	-	0%	-	0.9%	6.9%	0.2%	0%	7.1%	-	-
<b>PHF</b>	0.260	0.908	0.516	-	0.717	-	0.634	0.878	0.600	-	0.793	-	-	-	0.600	0.658	0.260	-	0.526	-	0.754
<b>Lights</b>	4	55	67	0	127	-	89	166	8	0	262	-	0	-	4	24	1	0	29	-	408
<b>% Lights</b>	100%	96.7%	95.5%	0%	95.2%	-	94.7%	97.6%	100%	0%	95.5%	-	-	-	100%	95.0%	100%	0%	95.7%	-	95.6%
<b>Articulated Trucks and Single-Unit Trucks</b>	0	3	0	0	3	-	0	3	0	0	3	-	0	-	0	1	0	0	1	-	7
<b>% Articulated Trucks and Single-Unit Trucks</b>	0%	4.3%	0%	0%	2.3%	-	0%	1.9%	0%	0%	1.1%	-	-	-	0%	4.0%	0%	0%	3.3%	-	1.7%
<b>Buses</b>	0	0	2	0	2	-	6	0	0	0	6	-	0	-	0	0	0	0	0	-	7
<b>% Buses</b>	0%	0%	3.4%	0%	1.6%	-	6.3%	0%	0%	0%	1.9%	-	-	-	0%	0%	0%	0%	0%	-	1.7%
<b>Bicycles on Road</b>	0	0	0	0	0	-	0	1	0	0	1	-	0	-	0	0	0	0	0	-	1
<b>% Bicycles on Road</b>	0%	0%	0%	0%	0%	-	0%	0.5%	0%	0%	0.4%	-	-	-	0%	0%	0%	0%	0%	-	0.2%
<b>Pedestrians</b>	-	-	-	-	-	0	-	-	-	-	-	3	-	0	-	-	-	-	-	2	-
<b>% Pedestrians</b>	-	-	-	-	-	-	-	-	-	-	-	100%	-	-	-	-	-	-	-	100%	-
<b>Bicycles on Crosswalk</b>	-	-	-	-	-	0	-	-	-	-	-	0	-	0	-	-	-	-	-	0	-
<b>% Bicycles on Crosswalk</b>	-	-	-	-	-	-	-	-	-	-	-	0%	-	-	-	-	-	-	-	0%	-

\*Pedestrians and Bicycles on Crosswalk. L: Left, R: Right, T: Thru, U: U-Turn

East Market Street-N Parsonage Street Weekda... - TMC

Wed Mar 1, 2023

AM Peak (7:30 AM - 8:30 AM) - Overall Peak Hour

All Classes (Lights, Articulated Trucks and Single-Unit Trucks, Buses, Pedestrians, Bicycles on Road, Bicycles on Crosswalk)

All Movements

ID: 1042889, Location: 41.927228, -73.90652



Provided by: Creighton Manning Engineering, LLP  
2 Winners Circle,  
Albany, NY, 12206, US

[N] N Parsonage St

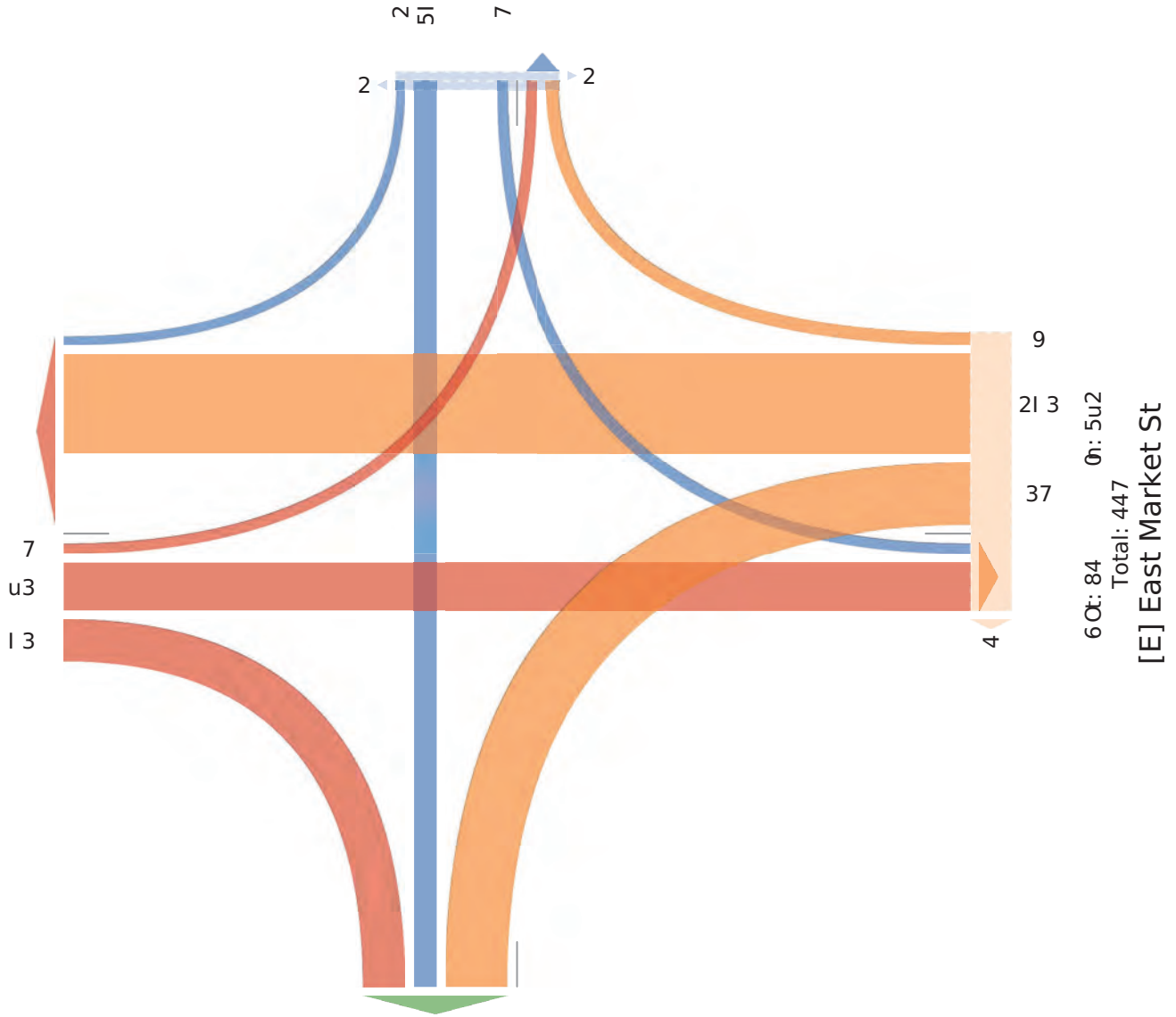
Total: 75

0t: 41 6Ot: 25

[W] East Market St

Total: 535

0t: 245 6Ot: 2u1



6Ot: 289 0t: 1  
Total: 289

[S] N Parsonage St

South Street-N Parsonage St-S Parsonage St W... - TMC

Wed Mar 1, 2023

Full Length (7 AM-9 AM)

All Classes (Lights, Articulated Trucks and Single-Unit Trucks, Buses, Pedestrians, Bicycles on Road, Bicycles on Crosswalk)

All Movements

ID: 1042892, Location: 41.926306, -73.905519



Provided by: Creighton Manning Engineering, LLP  
2 Winners Circle,  
Albany, NY, 12205, US

Leg Direction	South St Eastbound					South St Westbound					S Parsonage St Northbound					N Parsonage St Southbound					Int
	T	R	U	App	Ped*	L	T	U	App	Ped*	L	R	U	App	Ped*	L	T	R	App	Ped*	
2023-03-01 7:00AM	2	1	0	3	0	4	2	0	6	0	2	6	0	8	2	0	18	1	19	0	36
7:15AM	0	4	0	4	0	5	1	0	6	1	3	9	0	12	0	0	28	0	28	0	50
7:30AM	1	7	0	8	0	5	4	0	9	2	23	17	0	40	0	0	77	1	78	1	135
7:45AM	1	7	0	8	1	9	7	0	16	0	43	42	0	85	0	0	67	0	67	0	176
Hourly Total	4	19	0	23	1	23	14	0	37	3	71	74	0	145	2	0	190	2	192	1	397
8:00AM	4	2	0	6	0	7	0	0	7	0	21	19	0	40	0	0	17	0	17	0	70
8:15AM	2	4	0	6	0	8	7	0	15	0	6	7	0	13	0	0	17	0	17	0	51
8:30AM	4	9	0	13	0	3	1	0	4	0	13	15	0	28	0	0	31	0	31	0	76
8:45AM	2	5	0	7	1	3	2	0	5	0	38	27	0	65	0	1	25	0	26	0	103
Hourly Total	12	20	0	32	1	21	10	0	31	0	78	68	0	146	0	1	90	0	91	0	300
<b>Total</b>	16	39	0	55	2	44	24	0	68	3	149	142	0	291	2	1	280	2	283	1	697
<b>% Approach</b>	29.1%	70.9%	0%	-	-	64.7%	35.3%	0%	-	-	51.2%	48.8%	0%	-	-	0.4%	98.9%	0.7%	-	-	-
<b>% Total</b>	2.3%	5.6%	0%	7.9%	-	6.3%	3.4%	0%	9.8%	-	21.4%	20.4%	0%	41.8%	-	0.1%	40.2%	0.3%	40.6%	-	-
<b>Lights</b>	15	38	0	53	-	44	23	0	67	-	144	133	0	277	-	1	263	1	265	-	662
<b>% Lights</b>	93.8%	97.4%	0%	96.4%	-	100%	95.8%	0%	98.5%	-	96.6%	93.7%	0%	95.2%	-	100%	93.9%	50.0%	93.6%	-	95.0%
<b>Articulated Trucks and Single-Unit Trucks</b>	1	0	0	1	-	0	0	0	0	-	1	2	0	3	-	0	1	0	1	-	5
<b>% Articulated Trucks and Single-Unit Trucks</b>	6.3%	0%	0%	1.8%	-	0%	0%	0%	0%	-	0.7%	1.4%	0%	1.0%	-	0%	0.4%	0%	0.4%	-	0.7%
<b>Buses</b>	0	1	0	1	-	0	1	0	1	-	4	7	0	11	-	0	14	1	15	-	28
<b>% Buses</b>	0%	2.6%	0%	1.8%	-	0%	4.2%	0%	1.5%	-	2.7%	4.9%	0%	3.8%	-	0%	5.0%	50.0%	5.3%	-	4.0%
<b>Bicycles on Road</b>	0	0	0	0	-	0	0	0	0	-	0	0	0	0	-	0	2	0	2	-	2
<b>% Bicycles on Road</b>	0%	0%	0%	0%	-	0%	0%	0%	0%	-	0%	0%	0%	0%	-	0%	0.7%	0%	0.7%	-	0.3%
<b>Pedestrians</b>	-	-	-	-	2	-	-	-	-	3	-	-	-	-	2	-	-	-	-	-	1
<b>% Pedestrians</b>	-	-	-	-	100%	-	-	-	-	100%	-	-	-	-	100%	-	-	-	-	-	100%
<b>Bicycles on Crosswalk</b>	-	-	-	-	0	-	-	-	-	0	-	-	-	-	0	-	-	-	-	-	0
<b>% Bicycles on Crosswalk</b>	-	-	-	-	0%	-	-	-	-	0%	-	-	-	-	0%	-	-	-	-	-	0%

\* Pedestrians and Bicycles on Crosswalk. L: Left, R: Right, T: Thru, U: U-Turn

South Street-N Parsonage St-S Parsonage St W... - TMC

Wed Mar 1, 2023

Full Length (7 AM-9 AM)

All Classes (Lights, Articulated Trucks and Single-Unit Trucks, Buses, Pedestrians, Bicycles on Road, Bicycles on Crosswalk)

All Movements

ID: 1042892, Location: 41.926306, -73.905519

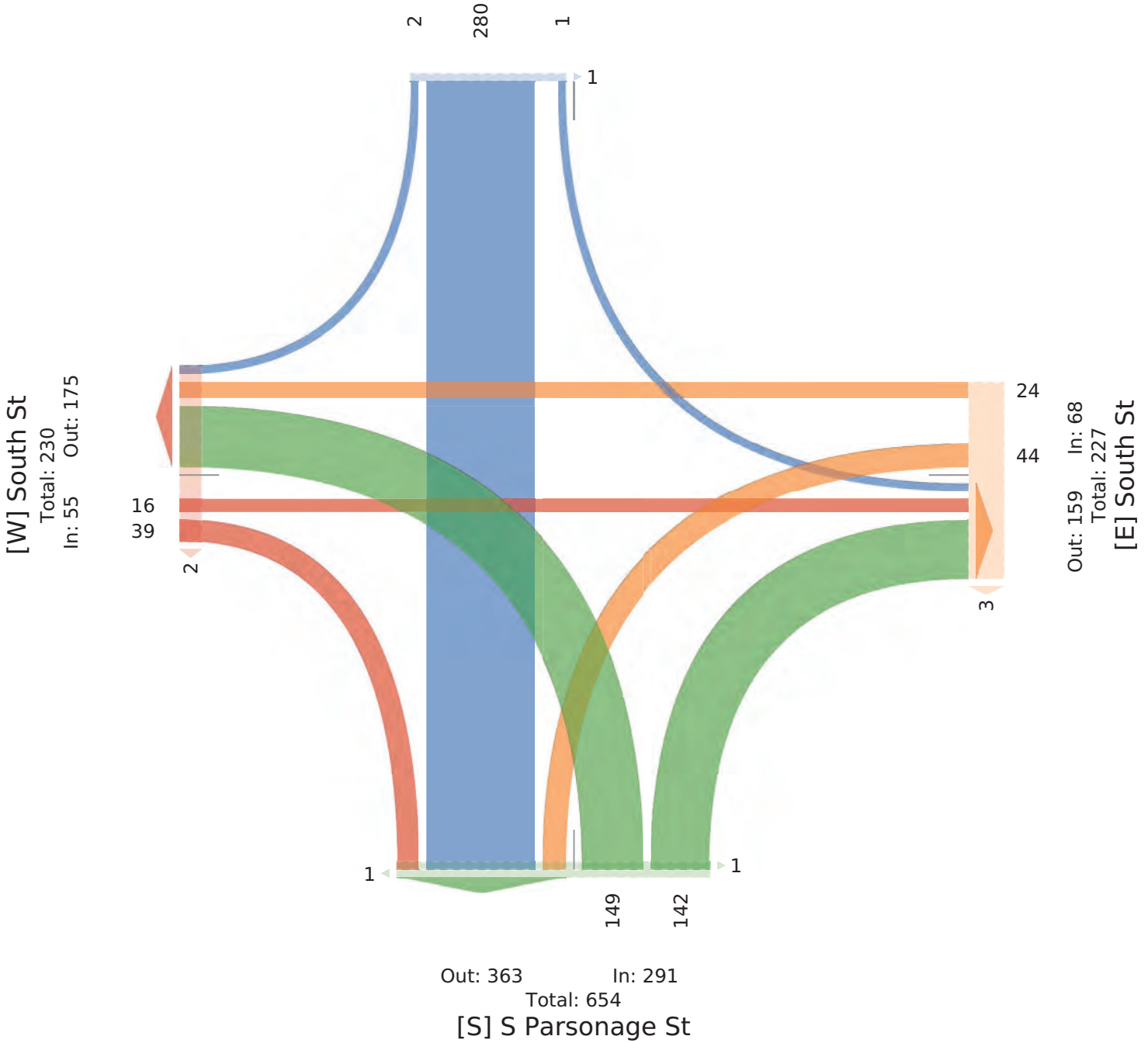


Provided by: Creighton Manning Engineering, LLP  
2 Winners Circle,  
Albany, NY, 12205, US

[N] N Parsonage St

Total: 283

In: 283 Out: 0





South Street-N Parsonage St-S Parsonage St W... - TMC

Wed Mar 1, 2023

AM Peak (7:30 AM - 8:30 AM) - Overall Peak Hour

All Classes (Lights, Articulated Trucks and Single-Unit Trucks, Buses, Pedestrians, Bicycles on Road, Bicycles on Crosswalk)

All Movements

ID: 1042892, Location: 41.926306, -73.905519



Provided by: Creighton Manning Engineering, LLP  
2 Winners Circle,  
Albany, NY, 12205, US

Leg Direction	South St Eastbound					South St Westbound					S Parsonage St Northbound					N Parsonage St Southbound					
Time	T	R	U	App	Ped*	L	T	U	App	Ped*	L	R	U	App	Ped*	L	T	R	App	Ped*	Int
2023-03-01 7:30AM	1	7	0	8	0	5	4	0	9	2	23	17	0	40	0	0	77	1	78	1	135
7:45AM	1	7	0	8	1	9	7	0	16	0	43	42	0	85	0	0	67	0	67	0	176
8:00AM	4	2	0	6	0	7	0	0	7	0	21	19	0	40	0	0	17	0	17	0	70
8:15AM	2	4	0	6	0	8	7	0	15	0	6	7	0	13	0	0	17	0	17	0	51
<b>Total</b>	<b>8</b>	<b>20</b>	<b>0</b>	<b>28</b>	<b>1</b>	<b>29</b>	<b>18</b>	<b>0</b>	<b>47</b>	<b>2</b>	<b>93</b>	<b>85</b>	<b>0</b>	<b>178</b>	<b>0</b>	<b>0</b>	<b>178</b>	<b>1</b>	<b>179</b>	<b>1</b>	<b>432</b>
<b>% Approach</b>	28.6%	71.4%	0%	-	-	61.7%	38.3%	0%	-	-	52.2%	47.8%	0%	-	-	0%	99.4%	0.6%	-	-	-
<b>% Total</b>	1.9%	4.6%	0%	6.5%	-	6.7%	4.2%	0%	10.9%	-	21.5%	19.7%	0%	41.2%	-	0%	41.2%	0.2%	41.4%	-	-
<b>PHF</b>	0.500	0.714	-	0.875	-	0.806	0.643	-	0.734	-	0.541	0.506	-	0.524	-	-	0.578	0.250	0.574	-	0.614
<b>Lights</b>	7	20	0	27	-	29	17	0	46	-	89	78	0	167	-	0	171	0	171	-	411
<b>% Lights</b>	87.5%	100%	0%	96.4%	-	100%	94.4%	0%	97.9%	-	95.7%	91.8%	0%	93.8%	-	0%	96.1%	0%	95.5%	-	95.1%
<b>Articulated Trucks and Single-Unit Trucks</b>	1	0	0	1	-	0	0	0	0	-	1	0	0	1	-	0	1	0	1	-	3
<b>% Articulated Trucks and Single-Unit Trucks</b>	12.5%	0%	0%	3.6%	-	0%	0%	0%	0%	-	1.1%	0%	0%	0.6%	-	0%	0.6%	0%	0.6%	-	0.7%
<b>Buses</b>	0	0	0	0	-	0	1	0	1	-	3	7	0	10	-	0	6	1	7	-	18
<b>% Buses</b>	0%	0%	0%	0%	-	0%	5.6%	0%	2.1%	-	3.2%	8.2%	0%	5.6%	-	0%	3.4%	100%	3.9%	-	4.2%
<b>Bicycles on Road</b>	0	0	0	0	-	0	0	0	0	-	0	0	0	0	-	0	0	0	0	-	0
<b>% Bicycles on Road</b>	0%	0%	0%	0%	-	0%	0%	0%	0%	-	0%	0%	0%	0%	-	0%	0%	0%	0%	-	0%
<b>Pedestrians</b>	-	-	-	-	1	-	-	-	-	2	-	-	-	-	0	-	-	-	-	-	1
<b>% Pedestrians</b>	-	-	-	-	100%	-	-	-	-	100%	-	-	-	-	-	-	-	-	-	-	100%
<b>Bicycles on Crosswalk</b>	-	-	-	-	0	-	-	-	-	0	-	-	-	-	0	-	-	-	-	-	0
<b>% Bicycles on Crosswalk</b>	-	-	-	-	0%	-	-	-	-	0%	-	-	-	-	-	-	-	-	-	-	0%

\* Pedestrians and Bicycles on Crosswalk. L: Left, R: Right, T: Thru, U: U-Turn

South Street-N Parsonage St-S Parsonage St W... - TMC

Wed Mar 1, 2023

AM Peak (7:30 AM - 8:30 AM) - Overall Peak Hour

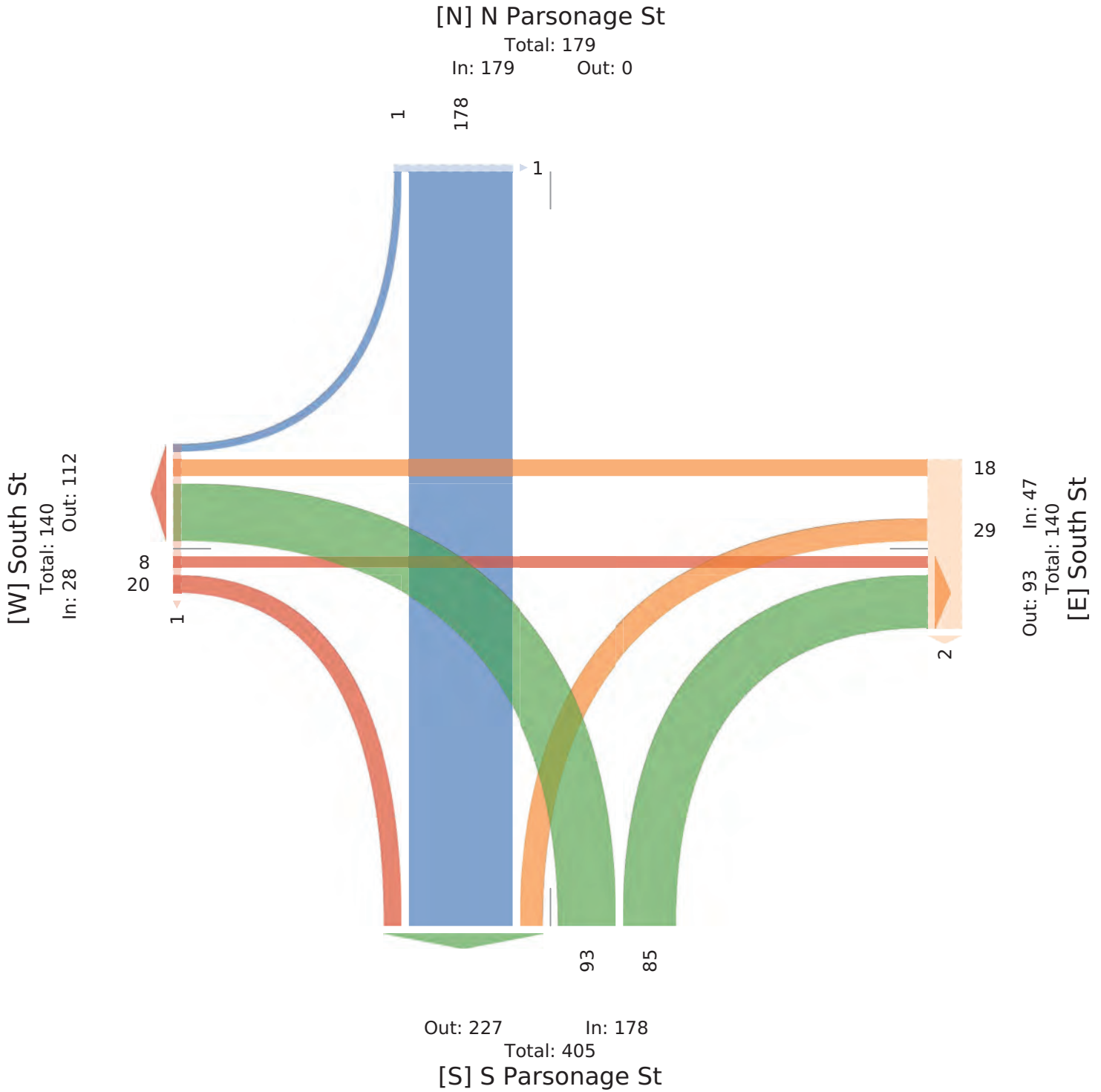
All Classes (Lights, Articulated Trucks and Single-Unit Trucks, Buses, Pedestrians, Bicycles on Road, Bicycles on Crosswalk)

All Movements

ID: 1042892, Location: 41.926306, -73.905519



Provided by: Creighton Manning  
Engineering, LLP  
2 Winners Circle,  
Albany, NY, 12205, US



East Market Street-Mulberry Street Weekday A... - TMC

Wed Mar 1, 2023

Full Length (7 AM-9 AM)

All Classes (Lights, Articulated Trucks and Single-Unit Trucks, Buses, Pedestrians, Bicycles on Road, Bicycles on Crosswalk)

All Movements

ID: 1042872, Location: 41.927144, -73.907469



Provided by: Creighton Manning  
Engineering, LLP  
2 Winners Circle,  
Albany, NY, 12206, US

Leg Direction	East Market St Eastbound						East Market St Westbound						Mulberry St Northbound						Mulberry St Southbound						Int
Time	L	T	R	U	AYY	Pedp	L	T	R	U	AYY	Pedp	L	T	R	U	AYY	Pedp	L	T	R	U	AYY	Pedp	Int
2023-03-01 7:00AM	2	21	0	0	23	0	0	1*	4	0	20	1	0	2	0	0	2	0	6	0	0	0	6	2	60
7:16AM	3	1*	0	0	19	0	0	26	8	0	33	0	1	1	0	0	2	0	6	4	0	0	9	2	*3
7:30AM	2	30	0	0	32	1	0	27	8	0	36	0	3	9	0	0	12	2	10	2	2	0	14	0	93
7:46AM	0	32	2	0	34	1	4	29	11	0	44	2	10	20	3	0	33	0	10	2	3	0	16	2	12*
Hourly Total	7	99	2	0	108	2	4	97	31	0	132	3	14	32	3	0	49	2	30	8	6	0	43	*	332
8:00AM	2	16	0	0	17	0	0	32	7	0	39	0	2	10	0	0	12	0	8	1	1	0	10	3	78
8:16AM	2	21	0	0	23	0	1	31	8	0	40	0	2	3	0	0	6	1	6	0	3	0	8	1	7*
8:30AM	2	21	0	0	23	2	2	28	4	0	34	0	10	6	3	0	18	2	4	2	0	0	*	0	81
8:46AM	0	33	1	0	34	1	1	39	12	0	62	0	13	17	1	0	31	2	3	3	3	0	9	1	12*
Hourly Total	*	90	1	0	97	3	4	130	31	0	1*6	0	27	36	4	0	**	6	20	*	7	0	33	6	3*1
9:00AM	0	0	0	0	0	0	0	1	0	0	1	0	0	0	0	0	0	0	0	0	0	0	0	0	1
Hourly Total	0	0	0	0	0	0	0	1	0	0	1	0	0	0	0	0	0	0	0	0	0	0	0	0	1
<b>Total</b>	13	189	3	0	206	6	8	228	*2	0	298	3	41	*7	7	0	116	7	60	14	12	0	7*	11	*94
<b>% AYYfoach</b>	*.3%	92.2%	1.6%	0%	-	-	2.7%	7*.6%	20.8%	0%	-	-	36.7%	68.3%	*.1%	0%	-	-	*6.8%	18.4%	16.8%	0%	-	-	-
<b>% Total</b>	1.9%	27.2%	0.4%	0%	29.6%	-	1.2%	32.9%	8.9%	0%	42.9%	-	6.9%	9.7%	1.0%	0%	1*.*%	-	7.2%	2.0%	1.7%	0%	11.0%	-	-
<b>Lights</b>	11	182	2	0	196	-	8	218	*1	0	287	-	40	*3	7	0	110	-	48	14	12	0	74	-	***
<b>% Lights</b>	84.*%	9*.3%	**.*7%	0%	96.1%	-	100%	96.*%	98.4%	0%	9*3.3%	-	97.*%	94.0%	100%	0%	96.7%	-	9*.0%	100%	100%	0%	97.4%	-	9*.0%
<b>Articulated Trucks and Single-Unit Trucks</b>	2	2	1	0	6	-	0	9	0	0	9	-	0	0	0	0	0	-	0	0	0	0	0	-	14
<b>% Articulated Trucks and Single-Unit Trucks</b>	16.4%	1.1%	33.3%	0%	2.4%	-	0%	3.9%	0%	0%	3.0%	-	0%	0%	0%	0%	0%	-	0%	0%	0%	0%	0%	-	2.0%
<b>Buses</b>	0	6	0	0	6	-	0	0	0	0	0	-	1	4	0	0	6	-	2	0	0	0	2	-	12
<b>% Buses</b>	0%	2.*%	0%	0%	2.4%	-	0%	0%	0%	0%	0%	-	2.4%	*.0%	0%	0%	4.3%	-	4.0%	0%	0%	0%	2.*%	-	1.7%
<b>Bicycles on Road</b>	0	0	0	0	0	-	0	1	1	0	2	-	0	0	0	0	0	-	0	0	0	0	0	-	2
<b>% Bicycles on Road</b>	0%	0%	0%	0%	0%	-	0%	0.4%	1.*%	0%	0.7%	-	0%	0%	0%	0%	0%	-	0%	0%	0%	0%	0%	-	0.3%
<b>Pedestrians</b>	-	-	-	-	-	4	-	-	-	-	-	3	-	-	-	-	-	7	-	-	-	-	-	11	
<b>% Pedestrians</b>	-	-	-	-	-	80.0%	-	-	-	-	-	100%	-	-	-	-	-	100%	-	-	-	-	-	100%	
<b>Bicycles on Crosswalk</b>	-	-	-	-	-	1	-	-	-	-	-	0	-	-	-	-	-	0	-	-	-	-	-	0	
<b>% Bicycles on Crosswalk</b>	-	-	-	-	-	20.0%	-	-	-	-	-	0%	-	-	-	-	-	0%	-	-	-	-	-	0%	

P Pedestrians and Bicycles on Crosswalk. L: Left, R: Right, T: Thru, U: U-Turn

East Market Street-Mulberry Street Weekday A... - TMC

Wed Mar 1, 2023

Full Length (7 AM-9 AM)

All Classes (Lights, Articulated Trucks and Single-Unit Trucks, Buses, Pedestrians, Bicycles on Road, Bicycles on Crosswalk)

All Movements

ID: 1042872, Location: 41.927144, -73.907459

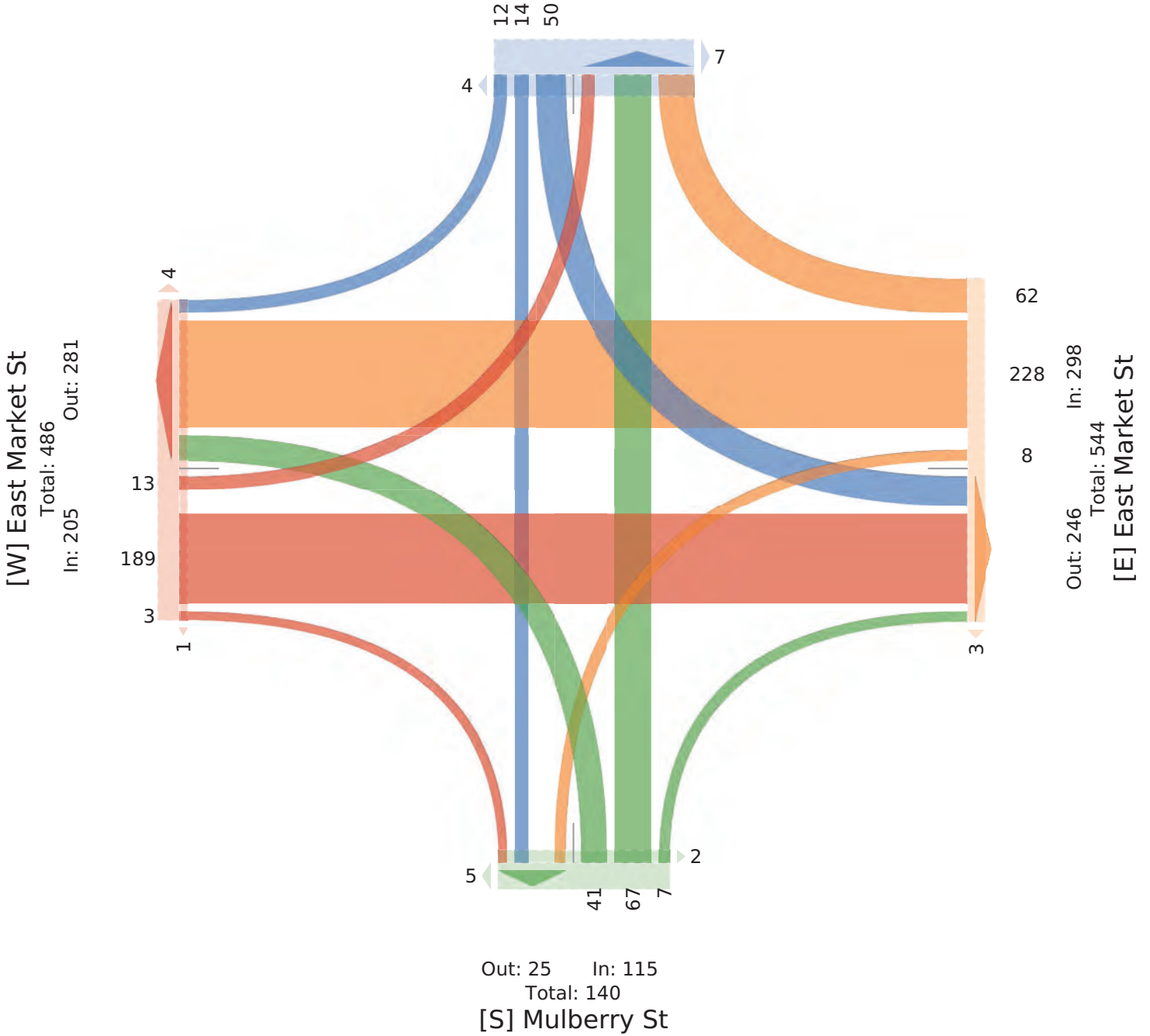


Provided by: Creighton Manning Engineering, LLP  
2 Winners Circle,  
Albany, NY, 12205, US

[N] Mulberry St

Total: 218

In: 76 Out: 142



East Market Street-Mulberry Street Weekday A... - TMC

Wed Mar 1, 2023

AM Peak (7:30 AM - 8:30 AM) - Overall Peak Hour

All Classes (Lights, Articulated Trucks and Single-Unit Trucks, Buses, Pedestrians, Bicycles on Road, Bicycles on Crosswalk)

All Movements

ID: 1042872, Location: 419 27144, -739 0746.



Provided by: Creighton Manning  
Engineering, LLP  
2 Winners Circle,  
Albany, EN, 12206, US

Leg Direction	East Market St Eastbound							East Market St Westbound							Mulberry St Northbound							Mulberry St Southbound							Int
	L	T	R	U	AYY	Pedp		L	T	R	U	AYY	Pedp		L	T	R	U	AYY	Pedp		L	T	R	U	AYY	Pedp		
2023-03-01 7:30AM	2	30	0	0	32	1		0	27	8	0	36	0		3	.	0	0	12	2		10	2	2	0	14	0		.3
7:46AM	0	32	2	0	34	1		4	2.	11	0	44	2		10	20	3	0	33	0		10	2	3	0	16	2		12*
8:00AM	2	16	0	0	17	0		0	32	7	0	3.	0		2	10	0	0	12	0		8	1	1	0	10	3		78
8:16AM	2	21	0	0	23	0		1	31	8	0	40	0		2	3	0	0	6	1		6	0	3	0	8	1		7*
<b>Total</b>	<b>*</b>	<b>.8</b>	<b>2</b>	<b>0</b>	<b>10*</b>	<b>2</b>		<b>6</b>	<b>11.</b>	<b>34</b>	<b>0</b>	<b>168</b>	<b>2</b>		<b>17</b>	<b>42</b>	<b>3</b>	<b>0</b>	<b>*2</b>	<b>3</b>		<b>33</b>	<b>6</b>	<b>.</b>	<b>0</b>	<b>47</b>	<b>*</b>		<b>373</b>
<b>% AYY</b>	69%	29%	19%	0%	-	-		39%	76%	21%	0%	-	-		27%	79%	49%	0%	-	-		70%	109%	1.9%	0%	-	-		-
<b>% Total</b>	19%	2*3%	0%	0%	28%	1%		19%	31%	.9%	0%	42%	1%		49%	119%	0%	0%	1*9%	1%		89%	19%	29%	0%	12%	1%		-
<b>PHF</b>	0.9760	0.97**	0.9260	-	0.977.	-		0.913	0.922	0.973	-	0.913	-		0.9426	0.926	0.9260	-	0.9470	-		0.926	0.926	0.9260	-	0.9283	-		0.944
<b>Lights</b>	<b>*</b>	<b>.6</b>	<b>2</b>	<b>0</b>	<b>103</b>	<b>-</b>		<b>6</b>	<b>114</b>	<b>34</b>	<b>0</b>	<b>163</b>	<b>-</b>		<b>1*</b>	<b>38</b>	<b>3</b>	<b>0</b>	<b>67</b>	<b>-</b>		<b>32</b>	<b>6</b>	<b>.</b>	<b>0</b>	<b>4*</b>	<b>-</b>		<b>36.</b>
<b>% Lights</b>	100%	*9%	100%	0%	.79%	-		100%	.69%	100%	0%	.*9%	-		.49%	.09%	100%	0%	.19%	-		.79%	100%	100%	0%	.79%	-		.*9%
<b>Articulated Trucks and Single-Unit Trucks</b>	<b>0</b>	<b>2</b>	<b>0</b>	<b>0</b>	<b>2</b>	<b>-</b>		<b>0</b>	<b>4</b>	<b>0</b>	<b>0</b>	<b>4</b>	<b>-</b>		<b>0</b>	<b>0</b>	<b>0</b>	<b>0</b>	<b>0</b>	<b>-</b>		<b>0</b>	<b>0</b>	<b>0</b>	<b>0</b>	<b>0</b>	<b>-</b>		<b>*</b>
<b>% Articulated Trucks and Single-Unit Trucks</b>	0%	29%	0%	0%	19%	-		0%	39%	0%	0%	29%	-		0%	0%	0%	0%	0%	-		0%	0%	0%	0%	0%	-		19%
<b>Buses</b>	<b>0</b>	<b>1</b>	<b>0</b>	<b>0</b>	<b>1</b>	<b>-</b>		<b>0</b>	<b>0</b>	<b>0</b>	<b>0</b>	<b>0</b>	<b>-</b>		<b>1</b>	<b>4</b>	<b>0</b>	<b>0</b>	<b>6</b>	<b>-</b>		<b>1</b>	<b>0</b>	<b>0</b>	<b>0</b>	<b>1</b>	<b>-</b>		<b>7</b>
<b>% Buses</b>	0%	19%	0%	0%	0%	-		0%	0%	0%	0%	0%	-		69%	.9%	0%	0%	89%	-		39%	0%	0%	0%	29%	-		19%
<b>Bicycles on Road</b>	<b>0</b>	<b>0</b>	<b>0</b>	<b>0</b>	<b>0</b>	<b>-</b>		<b>0</b>	<b>1</b>	<b>0</b>	<b>0</b>	<b>1</b>	<b>-</b>		<b>0</b>	<b>0</b>	<b>0</b>	<b>0</b>	<b>0</b>	<b>-</b>		<b>0</b>	<b>0</b>	<b>0</b>	<b>0</b>	<b>0</b>	<b>-</b>		<b>1</b>
<b>% Bicycles on Road</b>	0%	0%	0%	0%	0%	-		0%	0%	0%	0%	0%	-		0%	0%	0%	0%	0%	-		0%	0%	0%	0%	0%	-		0%
<b>Pedestrians</b>	<b>-</b>	<b>-</b>	<b>-</b>	<b>-</b>	<b>-</b>	<b>1</b>		<b>-</b>	<b>-</b>	<b>-</b>	<b>-</b>	<b>-</b>	<b>2</b>		<b>-</b>	<b>-</b>	<b>-</b>	<b>-</b>	<b>-</b>	<b>3</b>		<b>-</b>	<b>-</b>	<b>-</b>	<b>-</b>	<b>-</b>	<b>-</b>		<b>*</b>
<b>% Pedestrians</b>	-	-	-	-	-	60%		-	-	-	-	-	100%		-	-	-	-	-	100%		-	-	-	-	-	-		100%
<b>Bicycles on Crosswalk</b>	<b>-</b>	<b>-</b>	<b>-</b>	<b>-</b>	<b>-</b>	<b>1</b>		<b>-</b>	<b>-</b>	<b>-</b>	<b>-</b>	<b>-</b>	<b>0</b>		<b>-</b>	<b>-</b>	<b>-</b>	<b>-</b>	<b>-</b>	<b>0</b>		<b>-</b>	<b>-</b>	<b>-</b>	<b>-</b>	<b>-</b>	<b>-</b>		<b>0</b>
<b>% Bicycles on Crosswalk</b>	-	-	-	-	-	60%		-	-	-	-	-	0%		-	-	-	-	-	0%		-	-	-	-	-	-		0%

P Pedestrians and Bicycles on Crosswalk L: Left, R: Right, T: Thru, U: U-Turn

East Market Street-Mulberry Street Weekday A... - TMC

Wed Mar 1, 2023

AM Peak (7:30 AM - 8:30 AM) - Overall Peak Hour

All Classes (Lights, Articulated Trucks and Single-Unit Trucks, Buses, Pedestrians, Bicycles on Road, Bicycles on Crosswalk)

All Movements

ID: 1042872, Location: 41.927144, -73.907459



Provided by: Creighton Manning  
Engineering, LLP  
2 Winners Circle,  
Albany, NY, 12205, US

[N] Mulberry St

Total: 218

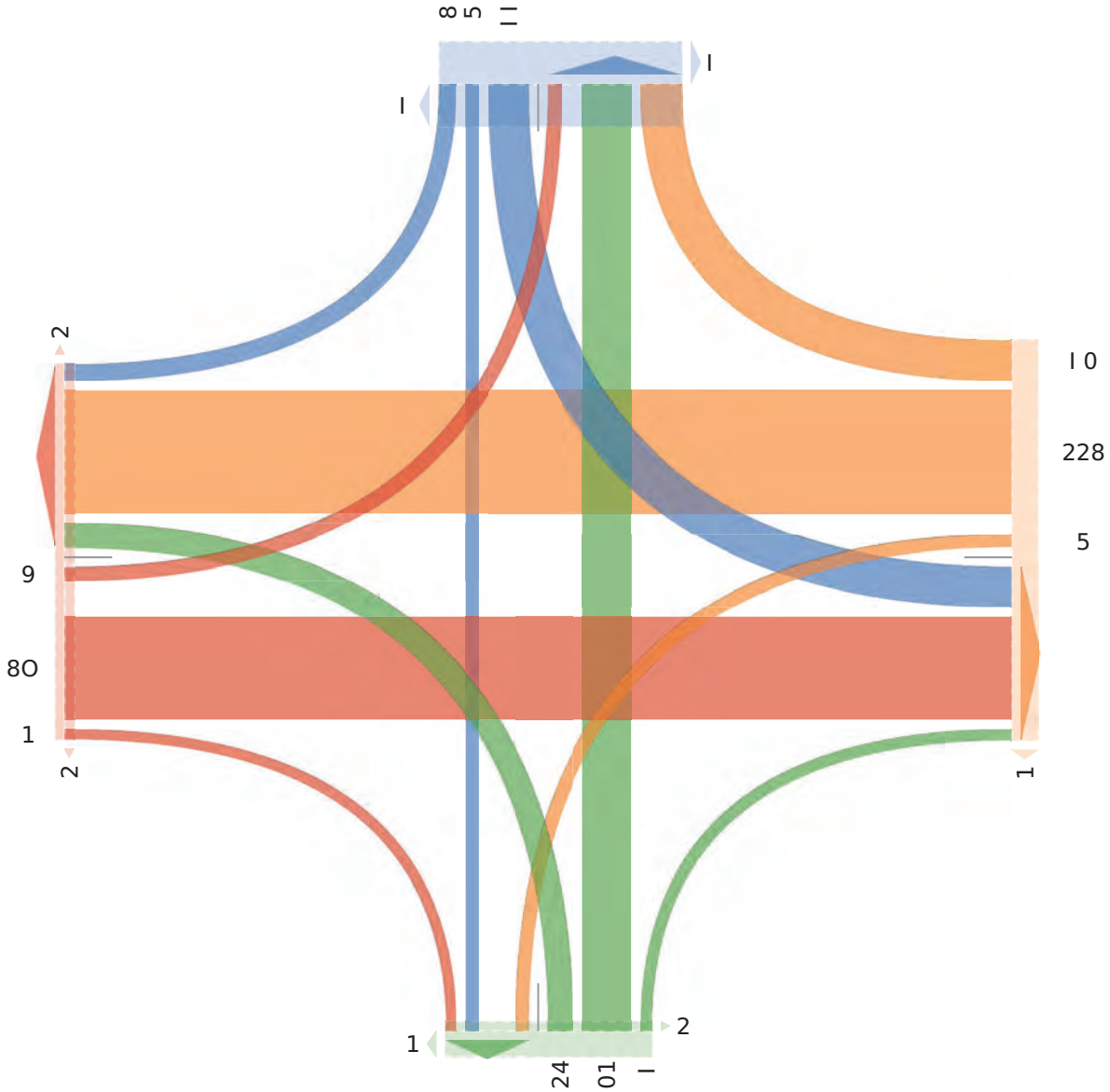
n̄: 04 6 ut: 01

8 5 11

[W] East Market St

Total: 152

n̄: 239 6 ut: 205



6 ut: 21 0 n̄: 250

Total: 181

[E] East Market St

6 ut: 21 n̄: 91

Total: 40

[S] Mulberry St

South Street-Mulberry Street Weekday School ... - TMC

Wed Mar 1, 2023

Full Length (2 7MA 7M9

) ll Classes (Lights, ) rticulated Trucks and SingleUnit Trucks, Buses, 7edestrians, BicPcles yn o yad, BicPcles yn CryssRalk9

) ll Mywev ents

ni D10-2: : 0, LycatiynD- 142. 016, A5348053- 1



7rywid bPDCreightyn Manning  
Engineering, LL7  
2 Winners Circle,  
) lbanP, NY, 12206, US

Leg I irectiyn	Syuth St Eastbyund					Syuth St Westbyund					MulberrP St Syuthbyund					
Tiv e	L	T	U	) pp	7ed*	T	o	U	) pp	7ed*	L	o	U	) pp	7ed*	mt
2023A03A01 2D07M	0	10	0	10	0	-	16	0	18	0	2	0	0	2	0	31
2D67M	2	11	0	13	0	5	8	0	1.	0	6	-	0	8	1	3:
2B07M	1	12	0	13	0	13	2-	0	35	0	:	0	0	:	0	6:
2D67M	2	11	0	13	1	21	-0	0	.1	0	-	2	0	.	.	:0
HyurLP Tytal	6	--	0	-8	1	-6	::	0	133	0	18	.	0	26	5	205
3D07M	0	11	0	11	0	5	13	0	20	0	.	0	0	.	3	35
3D67M	2	1-	0	1.	0	1-	21	0	36	0	3	0	0	3	0	6-
3B07M	0	.	0	.	0	21	33	0	6-	0	-	0	0	-	1	.-
3D67M	1	6	0	.	0	5	8	0	1.	0	-	0	0	-	0	2.
HyurLP Tytal	3	3.	0	38	0	-8	5.	0	126	0	15	0	0	15	-	1: 1
<b>Tytal</b>	:	:0	0	::	1	8-	1.-	0	26:	0	3.	.	0	-2	11	3::
<b>% ) ppyach</b>	84%	804%	0%	<b>A</b>	A	3.4%	.34%	0%	<b>A</b>	A	:64%	1-48%	0%	<b>A</b>	A	A
<b>% Tytal</b>	24%	204%	0%	<b>224%</b>	A	2-4%	-24%	0%	<b>..4%</b>	A	84%	146%	0%	<b>104%</b>	A	A
<b>Lights</b>	5	5.	0	:3	A	8-	16:	0	262	A	3-	.	0	-0	A	356
<b>% Lights</b>	:54%	864%	0%	<b>8-4%</b>	A	100%	8.4%	0%	<b>854%</b>	A	8-4%	100%	0%	<b>864%</b>	A	8.4%
<b>) rticulated Trucks and SingleUnit Trucks</b>	1	-	0	6	A	0	3	0	3	A	2	0	0	2	A	10
<b>% ) rticulated Trucks and SingleUnit Trucks</b>	124%	64%	0%	<b>64%</b>	A	0%	14%	0%	<b>14%</b>	A	64%	0%	0%	<b>-4%</b>	A	24%
<b>Buses</b>	0	0	0	0	A	0	3	0	3	A	0	0	0	0	A	3
<b>% Buses</b>	0%	0%	0%	<b>0%</b>	A	0%	14%	0%	<b>14%</b>	A	0%	0%	0%	<b>0%</b>	A	04%
<b>BicPcles yn o yad</b>	0	0	0	0	A	0	0	0	0	A	0	0	0	0	A	0
<b>% BicPcles yn o yad</b>	0%	0%	0%	<b>0%</b>	A	0%	0%	0%	<b>0%</b>	A	0%	0%	0%	<b>0%</b>	A	0%
<b>7edestrians</b>	A	A	A	A	1	A	A	A	A	0	A	A	A	A	11	
<b>% 7edestrians</b>	A	A	A	A	100%	A	A	A	A	A	A	A	A	A	100%	A
<b>BicPcles yn CryssRalk</b>	A	A	A	A	0	A	A	A	A	0	A	A	A	A	0	
<b>% BicPcles yn CryssRalk</b>	A	A	A	A	0%	A	A	A	A	A	A	A	A	A	0%	A

\*7edestrians and BicPcles yn CryssRalk4LLEft, o Do ight, TDThru, UDUAFurn

South Street-Mulberry Street Weekday School ... - TMC

Wed Mar 1, 2023

Full Length (2 7MA 7M9

) ll Classes (Lights, ) rticulated Trucks and SingleAUnit Trucks, Buses, 7edestrians, BicPcles yn o yad, BicPcles yn CryssRalk9

) ll Mywev ents

m DI0-2: : 0, LycatiynD- 1482. 016, A534053- 1



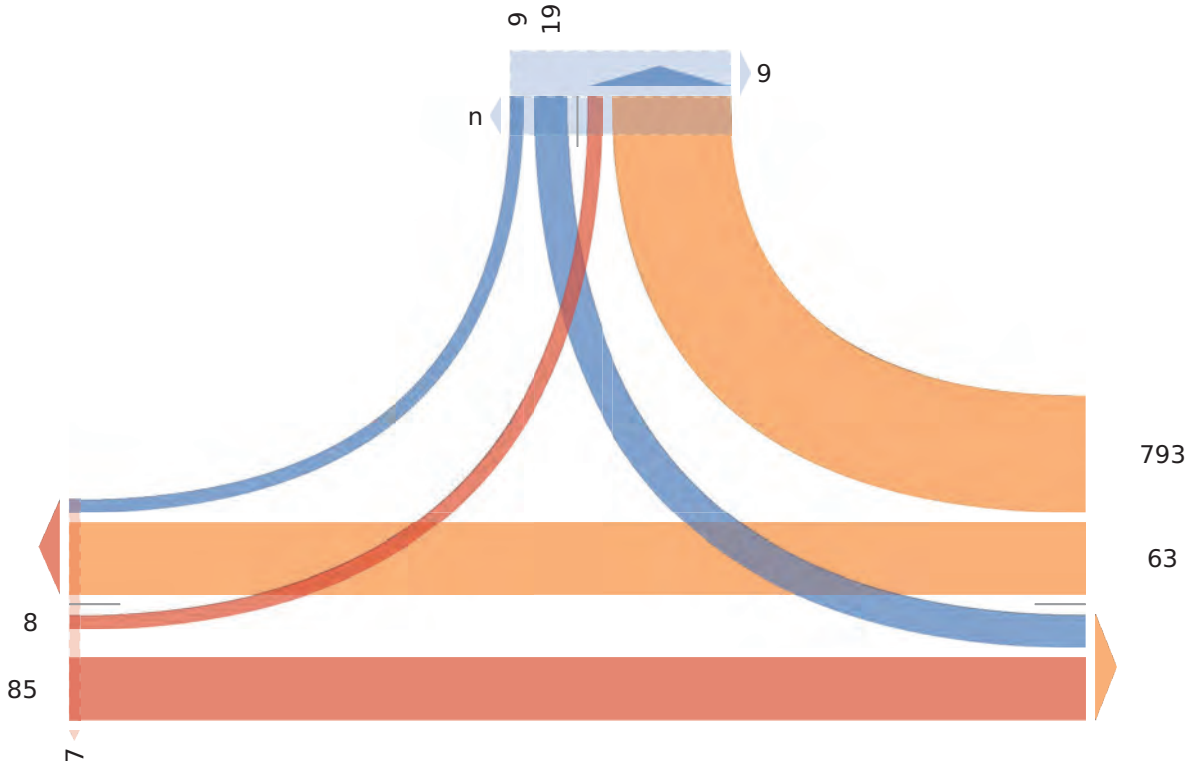
7rywided bPDCreightyn Manning  
Engineering, LL7  
2 Winners Circle,  
) lbanP, NY, 12206, US

[N] Mulberry St

Total: 073

0 : 30 2 ut: 740

[W] South St  
Total: 788  
0 : 88 2 ut: 755



2 ut: 779 0 : On8  
Total: 143  
[E] South St



South Street-Mulberry Street Weekday School ... - TMC

Wed Mar 1, 2023

AM AeaP k2(7: AM - 3(7: AM8- ) QerawAeaP l Hbr

u wCvasses kLlights, u rticovated TrocPs and Singe-Unit TrocPs, Boses, Aedestrians, Bicycves Hh RHhd, Bicycves Hh CrHsswaxP8

u wMHDelements

ID( 1072440, LHcatiHh( 719 2601: , -539 05371



ArHQided by( CreightH Manning Engineering, LLA  
2 Winners Circv, u vbany, NY, 1220: , US

Leg	SHbth St EastbHnd					SHbth St WestbHnd					Movberry St SHbthbHnd					
DirectiHh	L	T	U	u pp	Aed*	T	R	U	u pp	Aed*	L	R	U	u pp	Aed*	Int
Time																
2023-03-01 2(7: AM	2	11	0	13	1	21	70	0	61	0	7	2	0	6	6	40
3(00AM	0	11	0	11	0	5	13	0	20	0	6	0	0	6	3	35
3(1: AM	2	17	0	16	0	17	21	0	3:	0	3	0	0	3	0	: 7
3(30AM	0	6	0	6	0	21	33	0	: 7	0	7	0	0	7	1	67
<b>THav</b>	7	72	0	76	1	63	105	0	150	0	15	2	0	1.	10	23:
<b>% u pprHhch</b>	45%	. 19%	0%	-	-	359%	629%	0%	-	-	4. 9%	109%	0%	-	-	-
<b>% THav</b>	15%	159%	0%	1. 95%	-	269%	7: 9%	0%	529%	-	52%	09%	0%	49%	-	-
<b>Al F</b>	09 00	05: 0	-	051.	-	05: 0	056.	-	05. 5	-	0504	05: 0	-	05. 2	-	0537
<b>Lights</b>	7	3.	0	73	-	63	103	0	166	-	15	2	0	1.	-	224
<b>% Lights</b>	100%	. 29%	0%	. 39%	-	100%	. 69%	0%	. 59%	-	100%	100%	0%	100%	-	. 59%
<b>u rticovated TrocPs and Singe-Unit TrocPs</b>	0	3	0	3	-	0	1	0	1	-	0	0	0	0	-	7
<b>% u rticovated TrocPs and Singe-Unit TrocPs</b>	0%	59%	0%	69%	-	0%	09%	0%	09%	-	0%	0%	0%	0%	-	15%
<b>Boses</b>	0	0	0	0	-	0	3	0	3	-	0	0	0	0	-	3
<b>% Boses</b>	0%	0%	0%	0%	-	0%	29%	0%	19%	-	0%	0%	0%	0%	-	19%
<b>Bicycves Hh RHhd</b>	0	0	0	0	-	0	0	0	0	-	0	0	0	0	-	0
<b>% Bicycves Hh RHhd</b>	0%	0%	0%	0%	-	0%	0%	0%	0%	-	0%	0%	0%	0%	-	0%
<b>Aedestrians</b>	-	-	-	-	1	-	-	-	-	0	-	-	-	-	10	
<b>% Aedestrians</b>	-	-	-	-	100%	-	-	-	-	-	-	-	-	-	100%	-
<b>Bicycves Hh CrHsswaxP</b>	-	-	-	-	0	-	-	-	-	0	-	-	-	-	0	
<b>% Bicycves Hh CrHsswaxP</b>	-	-	-	-	0%	-	-	-	-	-	-	-	-	-	0%	-

\* Aedestrians and Bicycves Hh CrHsswaxP9L( Left, R( Right, T( Thro, U( U-Torn

South Street-Mulberry Street Weekday School ... - TMC

Wed Mar 1, 2023

AM AeaP k2(7: AM - 3(7: AM8- ) QerawAeaP1 Hbr

u wCvases kLlghts, u rticovated TrocPs and Singe-Unit TrocPs, Boses, Aedestrians, Bicycves  
Hh RHhd, Bicycves Hh CrHswwaP8

u wMHQements

ID( 1072440, LHatiH( 719 2601: , -539 05371



ArHQded by( CreightH Manning  
Engineering, LLA  
2 Winners Circe,  
u vbany, NY, 1220: , US

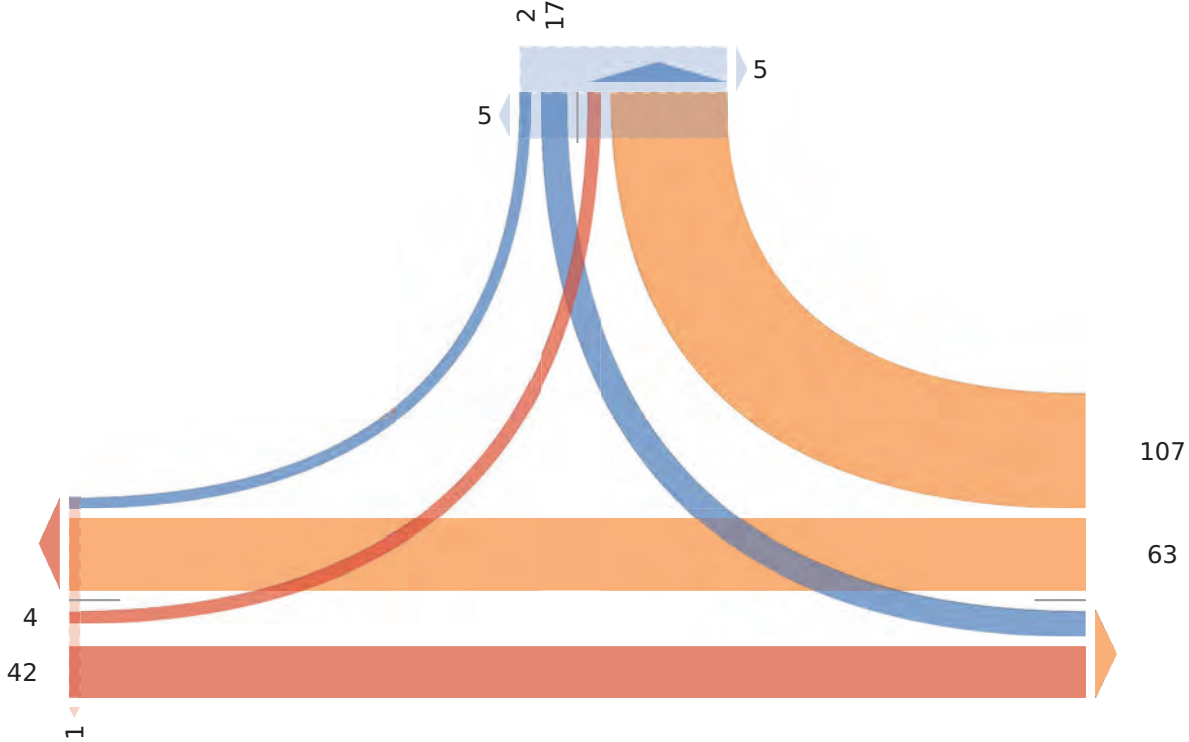
[N] Mulberry St

Total: 130

In: 19 Out: 111

[W] South St

Total: 111  
In: 46 Out: 65



East Market Street-Mulberry Street Weekday S... - TMC

Wed Mar 1, 2023

Full Length (2 7MA 7M9

) ll Classes (Lights, ) rticulated Trucks and SingleAUnit Trucks, Buses, 7edestrians, BicPcles yn o yad, BicPcles yn CryssRalk9

) ll Mywev ents

rh Dl0-2: 43, LycatiynD-18 241-- , A138 04-6.



7rywid 5PDCreightyn Manning  
b ngeering, LL7  
2 Winners Circle,  
) 15anP, EN, 12206, US

Leg I irectiyn	bast Market St bast5yund	bast Market St West5yund	Mul5errP St Eyrth5yund	Mul5errP St Syuth5yund	
Tiv e	L T o U ) YY 7edp	L T o U ) YY 7edp	L T o U ) YY 7edp	L T o U ) YY 7edp	mt
2023A03A012D07M	2 36 1 0 3: -	0 24 3 0 30 0	2 10 2 0 1- 0	. 1 4 0 14 1	..
2D67M	2 3: 2 0 -2 0	2 30 11 0 -3 1	2 4 1 0 10 1	: - 3 0 16 0	110
2B07M	13 -6 3 0 *1 0	0 2: 3 0 31 0	6 20 0 0 26 0	: 6 6 0 1: 1	136
2B67M	1 -3 1 0 -6 3	2 30 11 0 -3 0	10 2. - 0 -3 22	: 6 * 0 1. 2	160
HyurlP Tyal	1: 1*1 4 0 1: * 4	- 116 2: 0 1-4 1	1. ** 4 0 .2 23	33 16 21 0 *. -	-.-
3D07M	4 -0 0 0 -4 0	0 30 10 0 -0 0	1 11 1 0 13 2	. 6 1 0 16 1	116
3D67M	0 -0 0 0 -0 0	0 2: * 0 3- 0	* 16 1 0 22 3	10 3 2 0 16 0	111
3B07M	1 3. 2 0 -2 0	1 32 4 0 -0 0	12 21 1 0 3- 0	14 6 2 0 2- 0	1-0
3B67M	1 -1 1 0 -3 1	0 2: * 0 3- 0	1 : 2 0 11 2	10 3 3 0 1* 1	10-
HyurlP Tyal	. 1*0 3 0 142 1	1 11: 2. 0 1-: 0	20 66 6 0 :0 4	-* 1* : 0 40 2	-40
-D07M	0 0 0 0 0 0	0 1 0 0 1 0	0 0 0 0 0 0	0 0 0 0 0 0	1
HyurlP Tyal	0 0 0 0 0 0	0 1 0 0 1 0	0 0 0 0 0 0	0 0 0 0 0 0	1
<b>Tyal</b>	<b>24 321 10 0 36: :</b>	<b>6 23- 64 0 2. * 1</b>	<b>3. 121 12 0 142 30</b>	<b>4. 31 2. 0 13. * . *6</b>	
<b>% ) Yfryach</b>	<b>48% : . 8% 28 % 0% A</b>	<b>18% 4. 8% 1. 8% 0% A</b>	<b>22% 40% 48% 0% A</b>	<b>6*8 % 22% 208 % 0% A</b>	
<b>% Tyal</b>	<b>28 % 33% 18% 0% 34%</b>	<b>8% 2- 2% 68 % 0% 30%</b>	<b>-8% 12% 18% 0% 148 %</b>	<b>: 2% 32% 38% 0% 1-8 %</b>	
<b>Lights</b>	<b>24 313 10 0 360</b>	<b>6 230 66 0 2.0</b>	<b>3: 116 11 0 1*-</b>	<b>4: 2. 2: 0 136</b>	<b>. 3.</b>
<b>% Lights</b>	<b>100% . 48% 100% 0% . 48 %</b>	<b>100% . : 8% . *8% 0% . : 8%</b>	<b>. 48 % . 68% . 18% 0% . 68%</b>	<b>. : 8% . 38% . *8% 0% . 48%</b>	<b>. 48%</b>
<b>) rticulated Trucks and SingleAUnit Trucks</b>	<b>0 4 0 0 4</b>	<b>0 - 1 0 6</b>	<b>0 - 0 0 -</b>	<b>0 2 0 0 2</b>	<b>1:</b>
<b>% ) rticulated Trucks and SingleAUnit Trucks</b>	<b>0% 28% 0% 0% 28%</b>	<b>0% 18% 18 % 0% 18%</b>	<b>0% 38% 0% 0% 28%</b>	<b>0% *8% 0% 0% 18 %</b>	<b>18 %</b>
<b>Buses</b>	<b>0 0 0 0 0</b>	<b>0 0 0 0 0</b>	<b>1 2 0 0 3</b>	<b>1 0 0 0 1</b>	<b>-</b>
<b>% Buses</b>	<b>0% 0% 0% 0% 0%</b>	<b>0% 0% 0% 0% 0%</b>	<b>28% 18% 0% 0% 18%</b>	<b>18% 0% 0% 0% 8%</b>	<b>8%</b>
<b>BicPcles yn o yad</b>	<b>0 1 0 0 1</b>	<b>0 0 1 0 1</b>	<b>0 0 1 0 1</b>	<b>0 0 1 0 1</b>	<b>-</b>
<b>% BicPcles yn o yad</b>	<b>0% 8% 0% 0% 8%</b>	<b>0% 0% 18 % 0% 8%</b>	<b>0% 0% : 8% 0% 8%</b>	<b>0% 0% 38 % 0% 8%</b>	<b>8%</b>
<b>7edestrians</b>	<b>A A A A A :</b>	<b>A A A A A A 1</b>	<b>A A A A A A 2.</b>	<b>A A A A A A *</b>	
<b>% 7edestrians</b>	<b>A A A A A 100%</b>	<b>A A A A A A 100%</b>	<b>A A A A A A *8%</b>	<b>A A A A A A 100%</b>	
<b>BicPcles yn CryssRalk</b>	<b>A A A A A 0</b>	<b>A A A A A 0</b>	<b>A A A A A 1</b>	<b>A A A A A 0</b>	
<b>% BicPcles yn CryssRalk</b>	<b>A A A A A 0%</b>	<b>A A A A A 0%</b>	<b>A A A A A 38%</b>	<b>A A A A A 0%</b>	

P7edestrians and BicPcles yn CryssRalk8LLeft, o Do ight, TDFhru, UDUATurn

East Market Street-Mulberry Street Weekday S... - TMC

Wed Mar 1, 2023

Full Length (2 7MA 7M9

) ll Classes (Lights, ) rticulated Trucks and SingleAUnit Trucks, Buses, 7edestrians, BicPcles  
 yn o yad, BicPcles yn CryssRalk9

) ll Mywev ents

m DI0-2: 43, LycatiynD- 18 241-- , A38 04-5.



7rywided bPDCreightyn Manning  
 Engineering, LL7  
 2 Winners Circle,  
 ) lbanP, NY, 12205, US

[N] Mulberry St

Total: 211

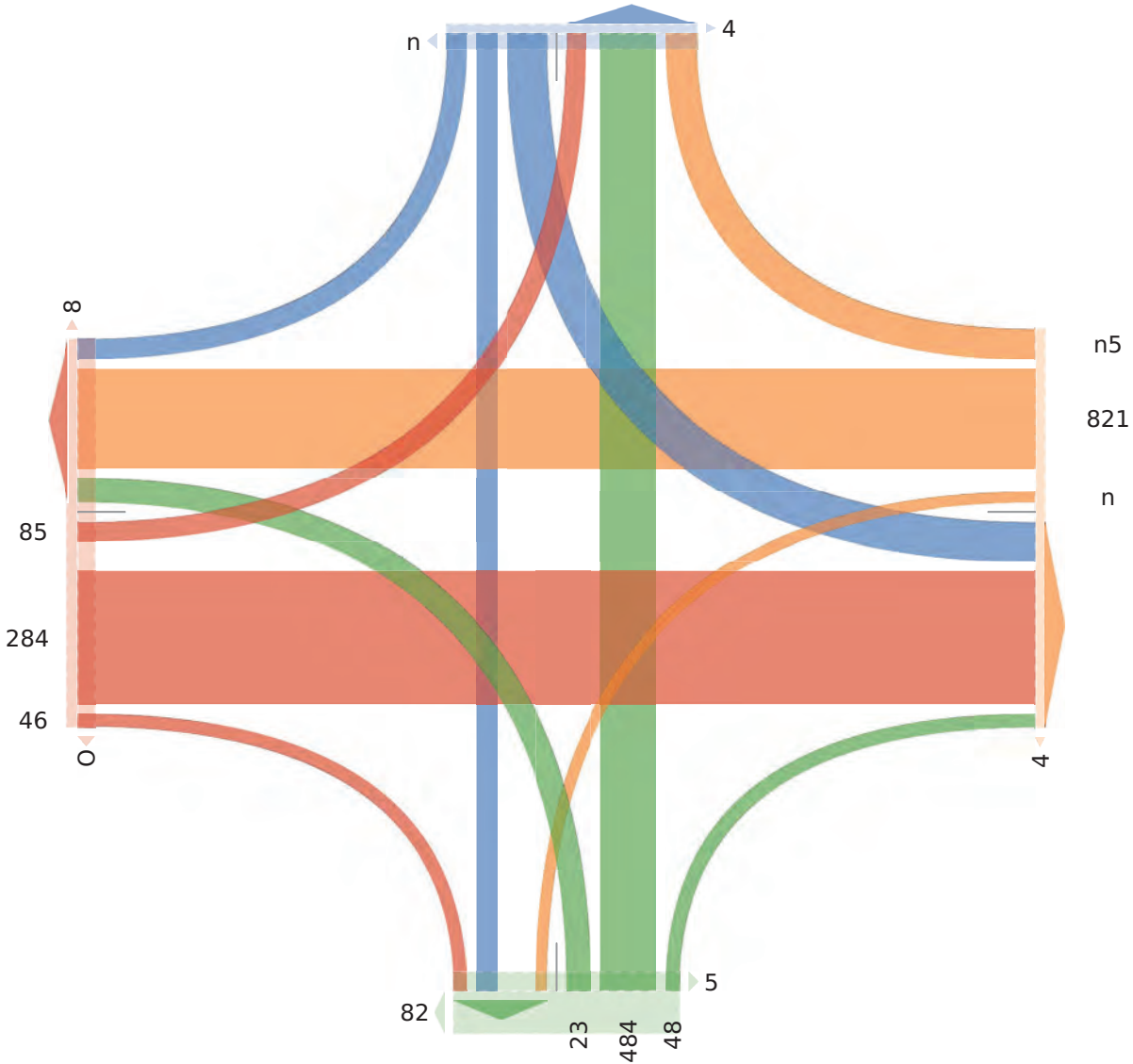
Ø: 423 l ut: 86n

83 24 53

[W] East Market St

Total: 006

Ø: 2n0 l ut: 268



l ut: 10 Ø: 458

Total: 840

[S] Mulberry St

East Market Street-Mulberry Street Weekday S... - TMC

Wed Mar 1, 2023

AM AeaP k2(7: AM - 3(7: AM8- ) CeraW AeaP l Hbr

u wCvasses kLlghts, u rticovated TrocPs and Singv-Unit TrocPs, Boses, Aedestrians, Bicycves H RHhd, Bicycves H CrHswaP8

u wMHDelements

ID( 1072493, LHatiHh( 71.629177, -93.6097: 6



ArHQded 5y( CreightH Manning  
bngineering, LLA  
2 Winners Cirvc,  
u v5any, EN, 1220: , US

Leg DirectiH	bast MarPet St bast5Hbnd							bast MarPet St West5Hbnd							MovBerry St EHth5Hbnd							MovBerry St SHbth5Hbnd							
Time	L	T	R	U	u	YY	Aedp	L	T	R	U	u	YY	Aedp	L	T	R	U	u	YY	Aedp	L	T	R	U	u	YY	Aedp	Int
2023-03-01 2(7: AM	1	73	1	0	7:		3	2	30	11	0	73	0	10	26	7	0	73	22	4	:	*	0	16	2	1:0			
3(00AM	9	70	0	0	79		0	0	30	10	0	70	0	1	11	1	0	13	2	6	:	1	0	1:	1	11:			
3(1: AM	0	70	0	0	70		0	0	24	*	0	37	0	*	1:	1	0	22	3	10	3	2	0	1:	0	111			
3(30AM	1	36	2	0	72		0	1	32	9	0	70	0	12	21	1	0	37	0	19	:	2	0	27	0	170			
<b>THav</b>	6	1*2	3	0	197		3	3	120	37	0	1:9	0	26	9*	9	0	112	29	77	14	11	0	93	3	:1*			
<b>% u YrHhch</b>	: .2%	63.1%	1.9%	0%	-	-	-	1.6%	9*.7%	21.9%	0%	-	-	2: .6%	*9.6%	*.3%	0%	-	-	*0.3%	27.9%	1: .1%	0%	-	-	-			
<b>% THav</b>	1.9%	31.7%	0.*%	0%	33.9%		-	0.*%	23.3%	*.*%	0%	30.7%	-	: .*%	17.9%	1.7%	0%	21.9%	-	4.: %	3.: %	2.1%	0%	17.1%	-	-			
<b>Al F</b>	0.321	0.672	0.39:	-	0.62*		-	0.39:	0.634	0.42:	-	0.626	-	0.*07	0.*:	0.39:	-	0.*7:	-	0.*79	0.600	0.:00	-	0.9:0	-	0.4*9			
<b>Lights</b>	6	1:*	3	0	1*4		-	3	120	32	0	1::	-	24	93	*	0	109	-	73	14	10	0	91	-	:01			
<b>% Lights</b>	100%	6*.3%	100%	0%	6*.*%		-	100%	100%	67.1%	0%	64.9%	-	6*.*%	6*.1%	4: .9%	0%	6: .: %	-	69.9%	100%	60.6%	0%	69.3%	-	69.1%			
<b>u rticovated TrocPs and Singv-Unit TrocPs</b>	0	*	0	0	*		-	0	0	1	0	1	-	0	1	0	0	1	-	0	0	0	0	0	-	4			
<b>% u rticovated TrocPs and Singv-Unit TrocPs</b>	0%	3.9%	0%	0%	3.7%		-	0%	0%	2.6%	0%	0.*%	-	0%	1.3%	0%	0%	0.6%	-	0%	0%	0%	0%	0%	-	1.*%			
<b>Boses</b>	0	0	0	0	0		-	0	0	0	0	0	-	1	2	0	0	3	-	1	0	0	0	1	-	7			
<b>% Boses</b>	0%	0%	0%	0%	0%		-	0%	0%	0%	0%	0%	-	3.7%	2.*%	0%	0%	2.9%	-	2.3%	0%	0%	0%	1.7%	-	0.4%			
<b>Bicycves H RHhd</b>	0	0	0	0	0		-	0	0	1	0	1	-	0	0	1	0	1	-	0	0	1	0	1	-	3			
<b>% Bicycves H RHhd</b>	0%	0%	0%	0%	0%		-	0%	0%	2.6%	0%	0.*%	-	0%	0%	17.3%	0%	0.6%	-	0%	0%	6.1%	0%	1.7%	-	0.*%			
<b>Aedestrians</b>	-	-	-	-	-	3		-	-	-	-	0		-	-	-	-	2*		-	-	-	-	-	3				
<b>% Aedestrians</b>	-	-	-	-	-	100%		-	-	-	-	-		-	-	-	-	-6*.3%		-	-	-	-	-	-100%				
<b>Bicycves H CrHswaP</b>	-	-	-	-	-	0		-	-	-	-	0		-	-	-	-	1		-	-	-	-	-	0				
<b>% Bicycves H CrHswaP</b>	-	-	-	-	-	0%		-	-	-	-	-		-	-	-	-	-3.9%		-	-	-	-	-	0%				

P Aedestrians and Bicycves H CrHswaP. L( Left, R( Right, T( Thro, U( U-Torn

East Market Street-Mulberry Street Weekday S... - TMC

Wed Mar 1, 2023

AM AeaP k2(7: AM - 3(7: AM8- ) QerawAeaP1 Hbr

u wCvasses kLlights, u rticovated TrocPs and Singv-Unit TrocPs, Boses, Aedestrians, Bicycves  
Hh RHhd, Bicycves Hh CrHswwP8

u wMHDelements

ID( 10724. 3, LHatiH( 7152. 177, -. 350. 7: 5



ArHQded by( CreightH Manning  
Engineering, LLA  
2 Winners Cirve,  
u vbany, NY, 1220: , US

[N] Mulberry St

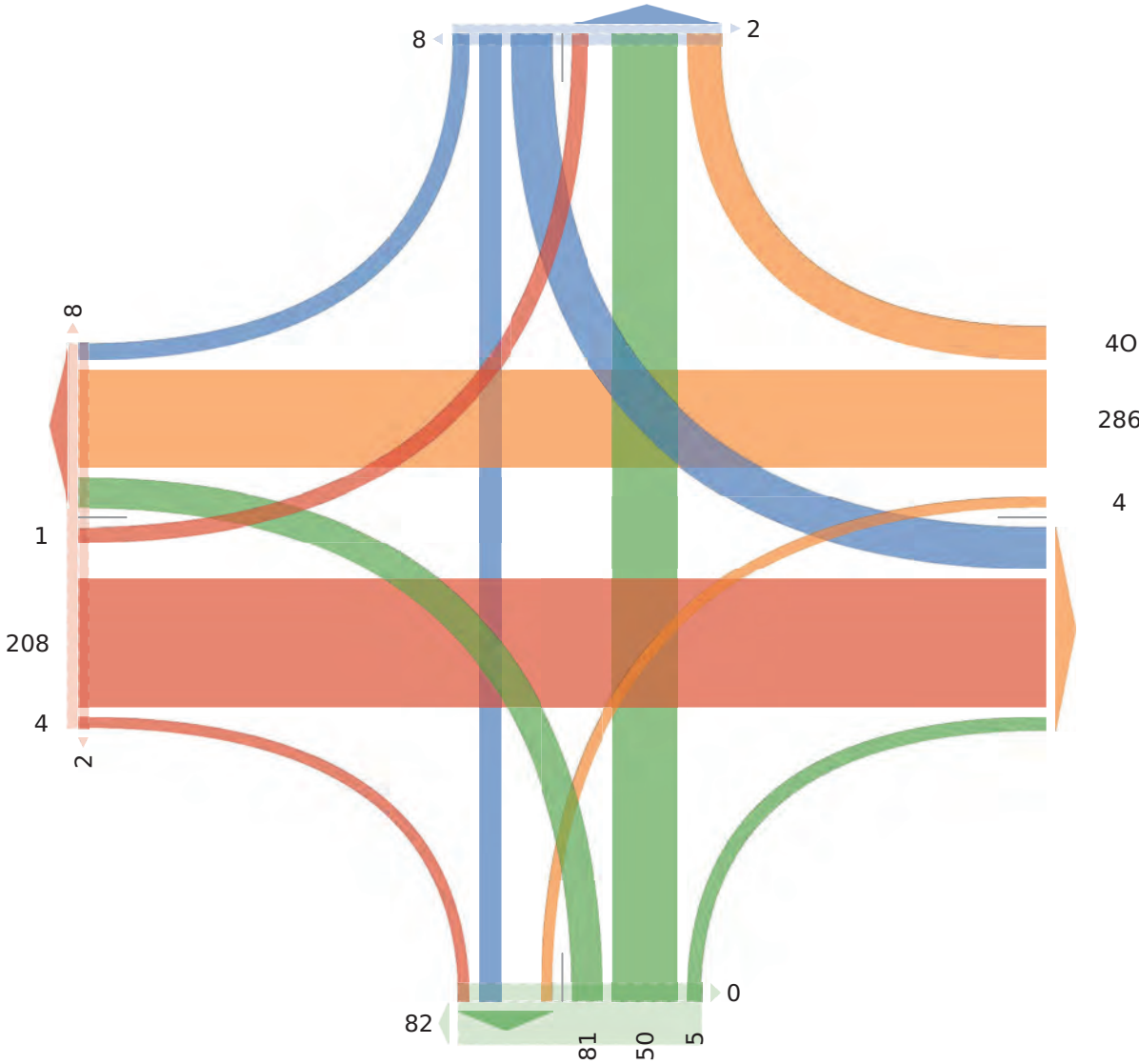
Total: 218

n̄: 54 I ut: 221

22 23 00

[W] East Market St

Total: 440  
n̄: 250 I ut: 206



I ut: 80 n̄: 228

Total: 240

[S] Mulberry St

East Market Street-N Parsonage Street Weekda... - TMC

Wed Mar 1, 2023

Full Length (2 7MA 7M9

) ll Classes (Lights, ) rticulated Trucks and SingleUnit Trucks, Buses, 7edestrians, BicPcles yn o yad, BicPcles yn CryssRalk9

) ll Mywev ents

ni D10-2: 41, LycatiynD- 1842. 22: , A 3840652



7rywid bPDCreightyn Manning  
Engineering, LL7  
2 Winners Circle,  
) lbanP, NY, 12206, US

Leg	East Market St						East Market St						N 7arsynage St		N 7arsynage St							
I irectiyn	Eastbyund						Westbyund						Nyrthbyund		Syuthbyund							
Tiv e	L	T	o	U	) pp	7ed*	L	T	o	U	) pp	7ed*	) pp	7ed*	L	T	o	U	) pp	7ed*	mt	
2023A03A01 2ID07M	3	3.	:	0	-:	0	-	30	3	0	3.	0	0	0	2	2	0	0	-	0	: 4	
2D67M	1	32	12	0	-6	0	12	-3	3	0	6:	0	0	0	1	-	2	0	.	0	110	
2D07M	1	-2	1-	0	6.	0	4	24	1	0	34	0	0	0	1	6	1	0	.	1	103	
2D67M	1	36	11	0	-.	6	5	-2	3	0	61	6	0	:	0	6	0	0	6	1	103	
HyurIP Tytal	5	1-5	-6	0	14.	6	31	1--	10	0	1:6	6	0	:	-	15	3	0	23	2	-06	
3D07M	0	-0	12	0	62	1	6	3:	3	0	-5	2	0	1	3	5	0	0	4	1	10.	
3D67M	0	-1	4	0	60	1	.	33	2	0	-2	0	0	1	-	10	0	0	1-	0	105	
3D07M	2	--	10	0	65	1	5	-1	3	0	60	2	0	1	5	1	0	0	.	0	113	
3D67M	0	-2	10	0	62	0	5	35	-	0	-5	0	0	1	0	-	0	0	-	1	102	
HyurIP Tytal	2	15.	-1	0	210	3	2-	1-:	12	0	1:-	-	0	-	13	21	0	0	3-	2	-2:	
-ID07M	0	0	0	0	0	0	0	1	0	0	1	0	0	0	0	0	0	0	0	0	1	
HyurIP Tytal	0	0	0	0	0	0	0	1	0	0	1	0	0	0	0	0	0	0	0	0	1	
<b>Tytal</b>	:	313	:	5	0	-0.	:	66	243	22	0	3.0	4	0	12	1.	3.	3	0	6.	-	: 3-
<b>% ) ppyach</b>	28%	. 58%	21%	0%	0%	A	1-8%	. 48%	68%	0%	0%	A	A	A	24%	5-8%	68%	0%	0%	A	A	
<b>% Tytal</b>	18%	3. 8%	10%	0%	0%	-: 8 %	55%	36%	25%	0%	-- 8 %	A	0%	A	28%	-8 %	0%	0%	58 %	A	A	
<b>Lights</b>	:	305	:	3	0	34.	A	-4	2:	:	22	0	364	A	0	A	15	3.	3	0	65	A : 12
<b>% Lights</b>	100%	4. 8 %	45%	0%	0%	4. 8%	A:	48%	4: 8%	100%	0%	4. 8%	A	A	A	4-8%	100%	100%	0%	4: 8%	A	4. 8 %
<b>) rticulated Trucks and SingleUnit Trucks</b>	0	5	2	0	:	A	1	6	0	0	5	A	0	A	1	0	0	0	1	A	16	
<b>% ) rticulated Trucks and SingleUnit Trucks</b>	0%	18%	28%	0%	0%	28%	A	18 %	18 %	0%	0%	18%	A	A	A	68%	0%	0%	0%	18 %	A	18 %
<b>Buses</b>	0	0	1	0	1	A	6	0	0	0	6	A	0	A	0	0	0	0	0	A	5	
<b>% Buses</b>	0%	0%	18%	0%	0%	08%	A	48%	0%	0%	0%	18 %	A	A	A	0%	0%	0%	0%	0%	A	08 %
<b>BicPcles yn o yad</b>	0	1	0	0	1	A	0	0	0	0	0	A	0	A	0	0	0	0	0	A	1	
<b>% BicPcles yn o yad</b>	0%	08%	0%	0%	0%	08%	A	0%	0%	0%	0%	0%	A	A	A	0%	0%	0%	0%	0%	A	08%
<b>7edestrians</b>	A	A	A	A	A	:	A	A	A	A	A	4	A	12	A	A	A	A	A	-		
<b>% 7edestrians</b>	A	A	A	A	A	100%	A	A	A	A	A	100%	A	100%	A	A	A	A	A	100%	A	
<b>BicPcles yn CryssRalk</b>	A	A	A	A	A	0	A	A	A	A	A	0	A	0	A	A	A	A	A	0		
<b>% BicPcles yn CryssRalk</b>	A	A	A	A	A	0%	A	A	A	A	A	0%	A	0%	A	A	A	A	A	0%	A	

\*7edestrians and BicPcles yn CryssRalk8L DLeft, o D o ight, TDFhru, UDUAFurn

East Market Street-N Parsonage Street Weekda... - TMC

Wed Mar 1, 2023

Full Length (2 7MA 7M9

) ll Classes (Lights, ) rticulated Trucks and SingleAUnit Trucks, Buses, 7edestrians, BicPcles  
 yn o yad, BicPcles yn CryssRalk9

) ll Mywev ents

m DI0-2: 41, LycatiynD-1&2. 22: , A 3&0652



7rywided bPDCreightyn Manning  
 Engineering, LL7  
 2 Winners Circle,  
 ) lbanP, NY, 12206, US

[N] N Parsonage St

Total: 75

4 3t: 98

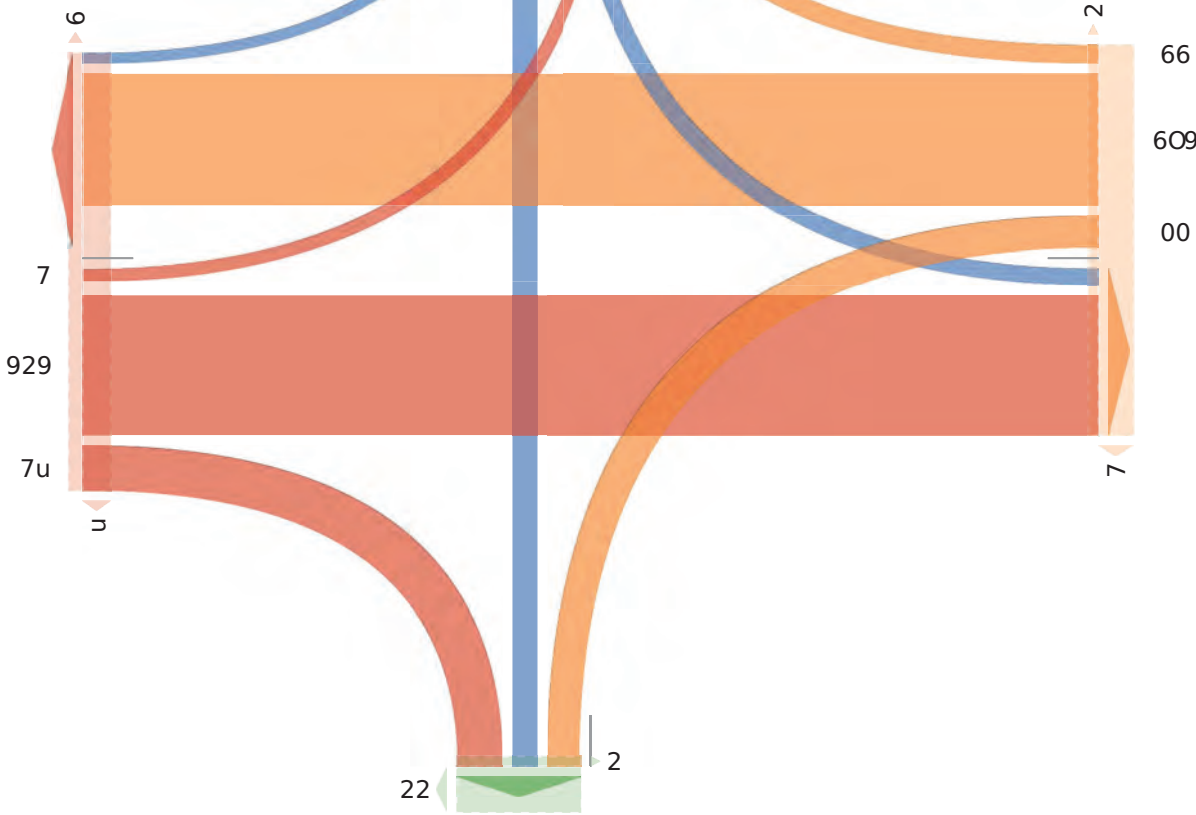
9 95 25

6 6

[W] East Market St

Total: 589

4 3t: 60u  
 n: 1 85



4 3t: 998  
 Total: 588  
 n: 958

[E] East Market St

4 3t: 257

n: 8

Total: 257

[S] N Parsonage St



East Market Street-N Parsonage Street Weekda... - TMC

Wed Mar 1, 2023

AM AeaP k2(7: AM - 3(7: AM8- ) QerawAeaP l Hbr

u wCvasses kLights, u rticovated TrocPs and Singve-Unit TrocPs, Boses, Aedestrians, Bicycves Hh RHhd, Bicycves Hh CrHswaP8

u wMHDelements

ID( 1072491, LHcatiHh( 71.926224, -63.90: 52



ArHQided by( CreightH Manning Engineering, LLA  
2 Winners Circve,  
u vbany, NY, 1220: , US

Leg	East MarPet St						East MarPet St						N AarsHhage St		N AarsHhage St							
DirectiHh	EastbHbnd						WestbHbnd						NHthbHbnd		SHthbHbnd							
Time	L	T	R	U	u pp	Aed*	L	T	R	U	u pp	Aed*	u pp	Aed*	L	T	R	U	u pp	Aed*	Int	
2023-03-01 2(7: AM	1	3:	11	0	76	:	5	72	3	0	:1	:	0	4	0	:	0	0	:	1	103	
3(00AM	0	70	12	0	:2	1	:	34	3	0	75	2	0	1	3	5	0	0	9	1	106	
3(1: AM	0	71	9	0	:0	1	6	33	2	0	72	0	0	1	7	10	0	0	17	0	105	
3(30AM	2	77	10	0	:5	1	5	71	3	0	:0	2	0	1	5	1	0	0	6	0	113	
<b>THav</b>	3	150	72	0	<b>20:</b>	4	27	1:7	11	0	<b>149</b>	9	0	11	13	22	0	0	<b>3:</b>	2	<b>729</b>	
<b>% u pprHhch</b>	1.:	64.0%	20.:	0%	-	-	12.6%	41.:	0%	-	-	-	-	-	36.1%	52.9%	0%	0%	-	-	-	
<b>% THav</b>	0.6%	36.3%	9.4%	0%	<b>76.4%</b>	-	.5%	3.:	9%	2.5%	0%	<b>77.1%</b>	-	<b>0%</b>	-	3.0%	.1%	0%	0%	<b>4.2%</b>	-	
<b>Al F</b>	0.36:	0.909	0.46:	-	<b>0.91:</b>	-	0.4:	6	0.916	0.916	-	<b>0.925</b>	-	-	0.:	72	0.:	0	-	<b>0.52:</b>	-	0.979
<b>Lights</b>	3	1:5	39	0	<b>194</b>	-	22	1:3	11	0	<b>145</b>	-	0	-	12	22	0	0	<b>37</b>	-	714	
<b>% Lights</b>	100%	96.:	92.9%	0%	<b>95.5%</b>	-	91.6%	99.7%	100%	0%	<b>94.7%</b>	-	-	-	92.3%	100%	0%	0%	<b>96.1%</b>	-	96.7%	
<b>u rticovated TrocPs and Singve-Unit TrocPs</b>	0	7	2	0	5	-	0	1	0	0	1	-	0	-	1	0	0	0	1	-	4	
<b>% u rticovated TrocPs and Singve-Unit TrocPs</b>	0%	2.:	7.4%	0%	<b>2.9%</b>	-	0%	0.5%	0%	0%	<b>0.:</b>	%	-	-	6.6%	0%	0%	0%	<b>2.9%</b>	-	1.9%	
<b>Boses</b>	0	0	1	0	1	-	2	0	0	0	2	-	0	-	0	0	0	0	0	-	3	
<b>% Boses</b>	0%	0%	2.7%	0%	<b>0.:</b>	%	4.3%	0%	0%	0%	<b>1.1%</b>	-	-	-	0%	0%	0%	0%	<b>0%</b>	-	0.6%	
<b>Bicycves Hh RHhd</b>	0	0	0	0	0	-	0	0	0	0	0	-	0	-	0	0	0	0	0	-	0	
<b>% Bicycves Hh RHhd</b>	0%	0%	0%	0%	<b>0%</b>	-	0%	0%	0%	0%	<b>0%</b>	-	-	-	0%	0%	0%	0%	<b>0%</b>	-	0%	
<b>Aedestrians</b>	-	-	-	-	-	4	-	-	-	-	-	9	-	11	-	-	-	-	-	2		
<b>% Aedestrians</b>	-	-	-	-	-	100%	-	-	-	-	-	100%	-	100%	-	-	-	-	-	100%	-	
<b>Bicycves Hh CrHswaP</b>	-	-	-	-	-	0	-	-	-	-	-	0	-	0	-	-	-	-	-	0		
<b>% Bicycves Hh CrHswaP</b>	-	-	-	-	-	0%	-	-	-	-	-	0%	-	0%	-	-	-	-	-	0%	-	

\*Aedestrians and Bicycves Hh CrHswaP. L( Left, R( Right, T( Thro, U( U-Torn

East Market Street-N Parsonage Street Weekda... - TMC

Wed Mar 1, 2023

AM AeaP k2(7: AM - 3(7: AM8- ) QerawAeaP1 Hbr

u wCvases kLlights, u rticovated TrocPs and Singve-Unit TrocPs, Boses, Aedestrians, Bicycves  
Hh RHhd, Bicycves Hh CrHswwaP8

u wMHDelements

ID( 1072491, LHatiH( 71.926224, -63.90: 52



ArHQded by( CreightH Manning  
Engineering, LLA  
2 Winners Circe,  
u vbany, NY, 1220: , US

[N] N Parsonage St

Total: 75

0n: 83 6Ot: u7

44 8

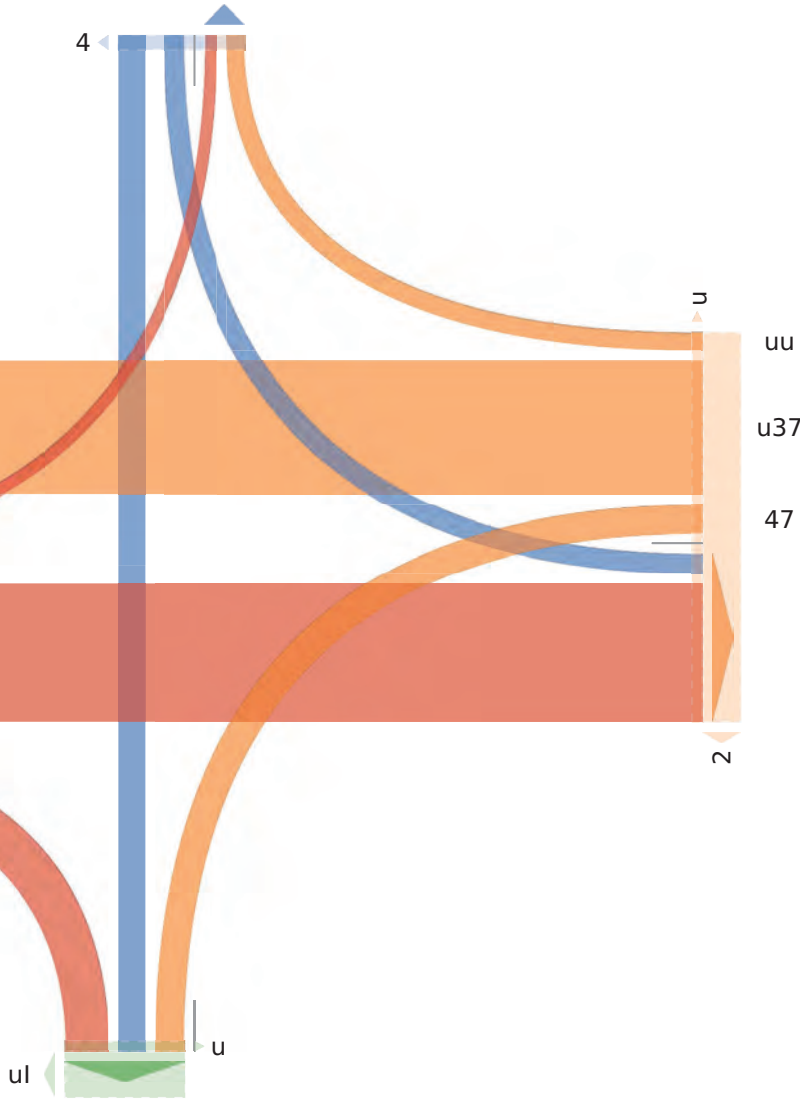
4

[W] East Market St

Total: 835

0n: 413 6Ot: u37

4  
8  
u9l  
74  
9



6Ot: u18 0n: u25

Total: 894

[E] East Market St

uu  
u37  
47

u

2

6Ot: 22 0n: 1

Total: 22

[S] N Parsonage St

South Street-N Parsonage St-S Parsonage St W... - TMC

Wed Mar 1, 2023

Full Length (2 7MA 7M9

) ll Classes (Lights, ) rticulated Trucks and Single Unit Trucks, Buses, 7edestrians, BicPcles yn o yad, BicPcles yn CryssRalk9

) ll Mywev ents

ni D10-2: 04, LycatiynD-18 24304, A 38 0661:



7rywid 5PDCreightyn Manning  
 bngneering, LL7  
 2 Winners Circle,  
 ) 15anP, E N, 12206, US

Leg I irectiyn	Syuth St bast5yund	Syuth St West5yund	S 7arsynage St Eyrth5yund	E 7arsynage St Syuth5yund	
Tiv e	T o U ) YY 7edp	L T U ) YY 7edp	L o U ) YY 7edp	L T o ) YY 7edp	mt
2023/03/01 21007M	. 6 0 12 0	4 1 0 . 0	1* . 0 26 0	1 12 1 1- 2	6*
21067M	2 11 0 13 1	: 1 0 10 1	13 3 0 14 0	1 24 0 2. 0	44
2107M	6 16 0 20 0	12 2 0 1- *	32 3. 0 4: 2	0 2. 3 30 0	133
21067M	6 11 0 14 0	4 - 0 10 30	66 3* 0 :3 -	0 23 0 23 3	1-2
HyurIP Tylal	1: -2 0 41 1	33 * 0 -1 3:	11* *6 0 203 4	2 ** - :- 6	3: :
31007M	- 12 0 14 2	. 3 0 10 .	1* 30 0 -* 0	1 22 0 23 2	..
31067M	4 11 0 1. 3	4 3 0 : 0	2. 2. 0 6- 0	1 26 2 2* 1	10*
3107M	- 4 0 10 1	6 3 0 * 2	-: 21 0 .0 0	0 16 2 1. 1	106
31067M	3 6 0 * 1	6 3 0 * 0	1- 1* 0 32 0	0 1- 2 14 0	4-
HyurIP Tylal	1. 3- 0 61 .	23 12 0 36 :	10* :4 0 20- 0	2 .4 4 *- -	3. -
<b>Tylal</b>	<b>34 .4 0 112 *</b>	<b>64 20 0 .4 -*</b>	<b>224 1*1 0 -.0. 4</b>	<b>- 14- 10 1.* :</b>	<b>..3</b>
<b>% ) Yfyach</b>	<b>32% 4.8% 0% 1-8%</b>	<b>38% 24% 0% 8%</b>	<b>66% --8% 0% 62%</b>	<b>2% :2% 6% 23%</b>	<b>A A</b>
<b>% Tylal</b>	<b>-8% :8% 0% 1-8%</b>	<b>.8% 2% 0% :8%</b>	<b>2: 2% 23% 0% 62%</b>	<b>A 0% 21% 18% 23%</b>	<b>A A</b>
<b>Lights</b>	<b>33 .3 0 104</b>	<b>63 20 0 .3</b>	<b>221 1.1 0 3:2</b>	<b>3 164 10 14:</b>	<b>A .-0</b>
<b>% Lights</b>	<b>:18% :4% 0% :-8%</b>	<b>:8% 100% 0% :4%</b>	<b>:.8% :-8% 0% :4%</b>	<b>A.6% :6% 100% :-8%</b>	<b>A:68%</b>
<b>) rticulated Trucks and Single Unit Trucks</b>	<b>3 3 0 4</b>	<b>2 0 0 2</b>	<b>2 2 0 -</b>	<b>0 3 0 3</b>	<b>A 16</b>
<b>% ) rticulated Trucks and Single Unit Trucks</b>	<b>*8% 38% 0% 68%</b>	<b>3% 0% 0% 2%</b>	<b>08% 1% 0% 1%</b>	<b>0% 18% 0% 18%</b>	<b>A 18%</b>
<b>Buses</b>	<b>0 0 0 0</b>	<b>1 0 0 1</b>	<b>3 * 0 11</b>	<b>0 6 0 6</b>	<b>A 1.</b>
<b>% Buses</b>	<b>0% 0% 0% 0%</b>	<b>18% 0% 0% 18%</b>	<b>18% -8% 0% 28%</b>	<b>A 0% 3% 0% 28%</b>	<b>A 2%</b>
<b>BicPcles yn o yad</b>	<b>0 0 0 0</b>	<b>0 0 0 0</b>	<b>0 0 0 0</b>	<b>1 0 0 1</b>	<b>A 1</b>
<b>% BicPcles yn o yad</b>	<b>0% 0% 0% 0%</b>	<b>0% 0% 0% 0%</b>	<b>0% 0% 0% 0%</b>	<b>A 26% 0% 0% 0%</b>	<b>A 0%</b>
<b>7edestrians</b>	<b>A A A A *</b>	<b>A A A A -.</b>	<b>A A A A 4</b>	<b>A A A A :</b>	
<b>% 7edestrians</b>	<b>A A A A 100%</b>	<b>A A A A :.8%</b>	<b>A A A A 100%</b>	<b>A A A A 100%</b>	<b>A</b>
<b>BicPcles yn CryssRalk</b>	<b>A A A A 0</b>	<b>A A A A 1</b>	<b>A A A A 0</b>	<b>A A A A 0</b>	
<b>% BicPcles yn CryssRalk</b>	<b>A A A A 0%</b>	<b>A A A A 2%</b>	<b>A A A A 0%</b>	<b>A A A A 0%</b>	<b>A</b>

P7edestrians and BicPcles yn CryssRalk8LDLeft, o Do ight, TDTthru, UDUAFurn

South Street-N Parsonage St-S Parsonage St W... - TMC

Wed Mar 1, 2023

Full Length (2 PM-4 PM)

All Classes (Lights, Articulated Trucks and Single-Unit Trucks, Buses, Pedestrians, Bicycles on Road, Bicycles on Crosswalk)

All Movements

ID: 1042906, Location: 41.926306, -73.905519

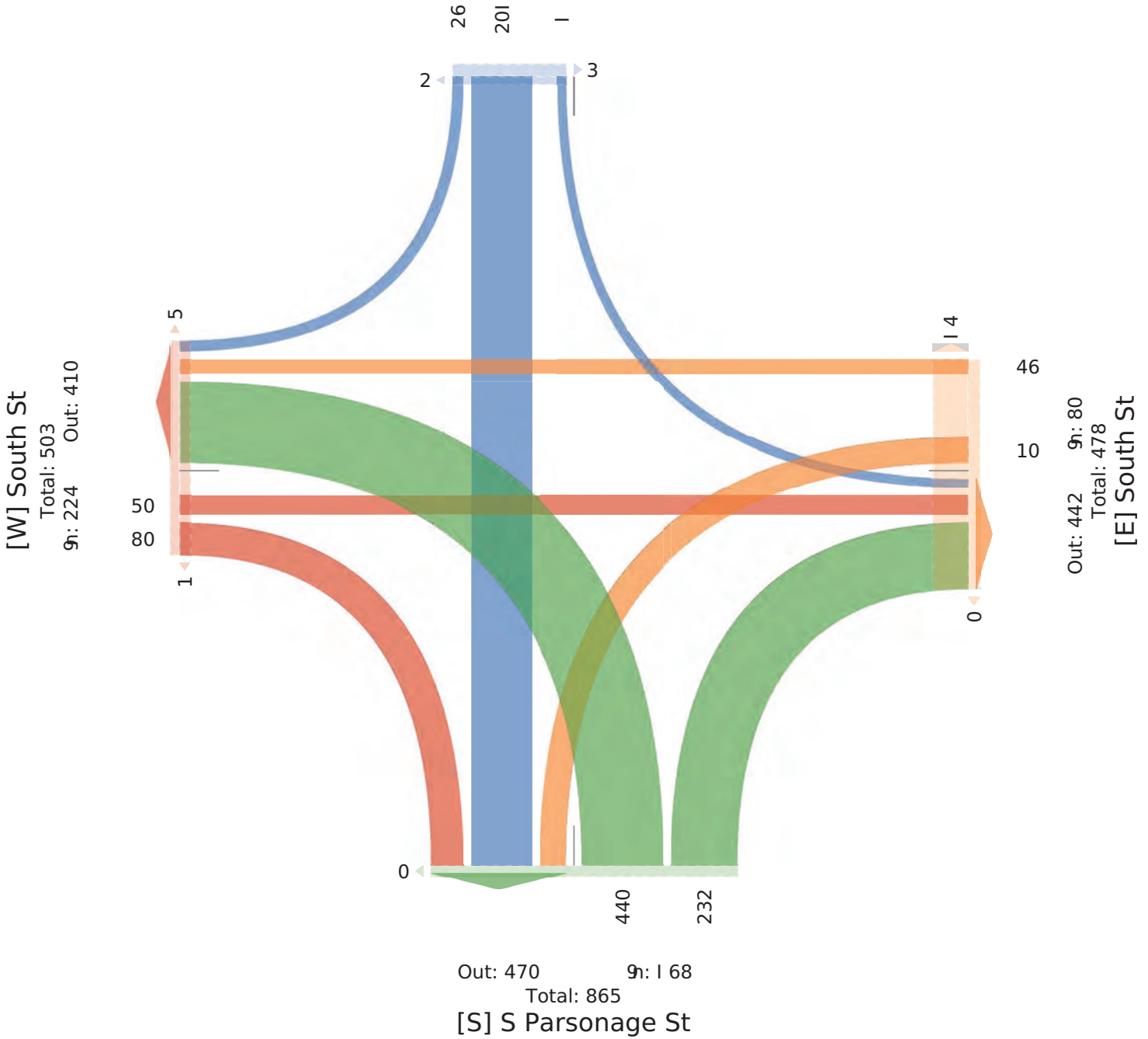


Provided by: Creighton Manning Engineering, LLP  
2 Winners Circle,  
Albany, NY, 12205, US

[N] N Parsonage St

Total: 283

g: 283 Out: 6



South Street-N Parsonage St-S Parsonage St W... - TMC

Wed Mar 1, 2023

AM AeaP k2(30 AM 73(30 AM: 7- 8era)) AeaP Ovl r

H)) o )auueu kCslI g, Hrgl )agd t rl hPu acd TscL)e7n csgt rl hPu, Sl ueu, Aedeugsacu, SshU)eu vc Bvad, SshU)eu vc orvuuy a)P:

H)) Mv8eRecgI

wm( 10I 2D04, Cvhagsvc( I 19D24304, 7. 39D0661D



Arv8sded 5U o resLi gyc MaccscL  
bcLsceerscL, CCA  
2 Wsceru o sh)e,  
H)5acU, E N, 12206, n T

CeL msrehgvc	Tvl g Tg baug5vl cd	Tvl g Tg Weug5vl cd	T AaruvcaLe Tg Evrg 5vl cd	E AaruvcaLe Tg Tvl g 5vl cd	
t sRe	t B n HYY Aedp	C t n HYY Aedp	C B n HYY Aedp	C t B HYY Aedp	wg
20230301 2(30AM	6 16 0 20 0	12 2 0 11 *	32 3. 0 4D 2	0 2. 3 30 0	133
2(16AM	6 11 0 14 0	4 1 0 10 30	66 3* 0 DB 1	0 23 0 23 3	112
3(00AM	1 12 0 14 2	. 3 0 10 .	1* 30 0 1* 0	1 22 0 23 2	D
3(16AM	4 11 0 1. 3	4 3 0 D 0	2. 2. 0 6I 0	1 26 2 2* 1	10*
<b>t vgr</b>	20 1D 0 4D 6	31 12 0 13 16	132 132 0 24I 4	2 D 6 10I 4	I*0
<b>% HYYvahi</b>	2D0% . 19% 0% 7 7	29% 2. 9% 0% 7 7	609% 609% 0% 7 7	19% D8% 19% 7 7	7
<b>% t vgr</b>	19% 10% 0% 119 % 7	49% 29% 0% D0% 7	2. 9% 2. 9% 0% 669% 7	09% 20% 19% 219 % 7	7
<b>AOF</b>	09*33 09*1. 7 09*43 7	09I4 09 60 7 09 4* 7	09I00 09*4* 7 09 10 7	0960 09*D* 09 1. 09*6* 7	09*13
<b>CsLi gi</b>	1* 14 0 4I 7	2D 12 0 11 7	12D 124 0 266 7	1 DB 6 ID 7	16D
<b>% CsLi gi</b>	D90% D8D% 0% D29% 7	D89% 100% 0% D68% 7	D 9 % D69% 0% D49% 7	609% D69% 100% D69% 7	D69%
<b>Hrgl )agd t rl hPu acd TscL)e7 n csgt rl hPu</b>	2 3 0 6 7	1 0 0 1 7	1 0 0 1 7	0 1 0 1 7	*
<b>% Hrgl )agd t rl hPu acd TscL)e7 n csgt rl hPu</b>	109% 49% 0% . 9% 7	39% 0% 0% 29% 7	09% 0% 0% 09 % 7	0% 19% 0% 19% 7	19 %
<b>Sl ueu</b>	0 0 0 0 7	1 0 0 1 7	2 4 0 * 7	0 3 0 3 7	12
<b>% Sl ueu</b>	0% 0% 0% 0% 7	39% 0% 0% 29% 7	19% 19% 0% 39% 7	0% 39% 0% 29% 7	29%
<b>SshU)eu vc Bvad</b>	0 0 0 0 7	0 0 0 0 7	0 0 0 0 7	1 0 0 1 7	1
<b>% SshU)eu vc Bvad</b>	0% 0% 0% 0% 7	0% 0% 0% 0% 7	0% 0% 0% 0% 7	609% 0% 0% 19% 7	09%
<b>Aedeugsacu</b>	7 7 7 7 6	7 7 7 7 11	7 7 7 7 4	7 7 7 7 4	
<b>% Aedeugsacu</b>	7 7 7 7 100%	7 7 7 7 D 9% 7	7 7 7 7 100%	7 7 7 7 100%	7
<b>SshU)eu vc orvuuy a)P</b>	7 7 7 7 0	7 7 7 7 1	7 7 7 7 0	7 7 7 7 0	
<b>% SshU)eu vc orvuuy a)P</b>	7 7 7 7 0%	7 7 7 7 29% 7	7 7 7 7 0%	7 7 7 7 0%	7

P Aedeugsacu acd SshU)eu vc orvuuy a)P9C( Cefg B( BsLi g t ( t i r l , n ( n 7 l r c

South Street-N Parsonage St-S Parsonage St W... - TMC

Wed Mar 1, 2023

PM Peak (2:30 PM - 3:30 PM) - Overall Peak Hour

All Classes (Lights, Articulated Trucks and Single-Unit Trucks, Buses, Pedestrians, Bicycles on Road, Bicycles on Crosswalk)

All Movements

ID: 1042906, Location: 41.926306, -73.905519



Provided by: Creighton Manning Engineering, LLP  
2 Winners Circle,  
Albany, NY, 12205, US

[N] N Parsonage St

Total: 283

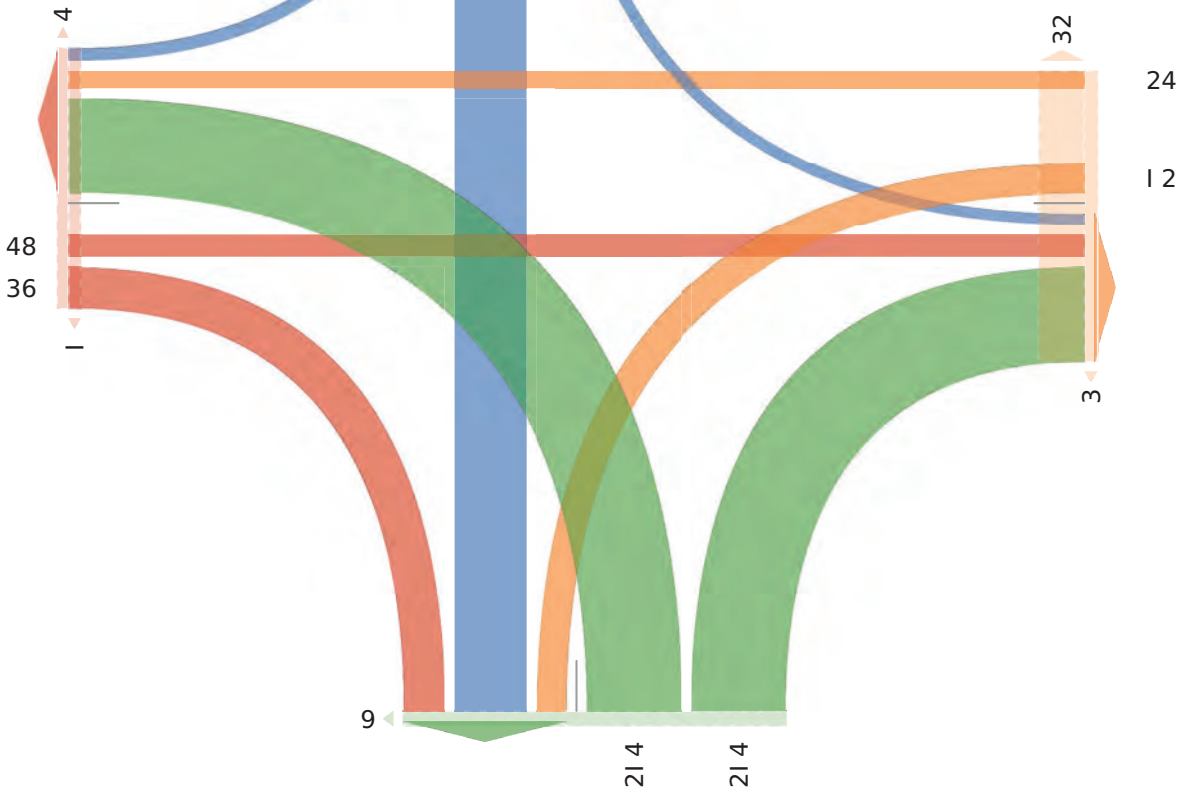
In: 283 Out: 8

0 65 4

2 0

[W] South St

Total: 427  
In: 96 Out: 236



0 out: 203 In: 31  
Total: 265  
[E] South St

0 out: 255 In: 493

Total: 332

[S] S Parsonage St

East Market Street-Mulberry Street Weekday PM - TMC

Wed Mar 1, 2023

Full Length (7 AM-9 AM)

Cl s lai ei (Lghti, Crtcfiluted kruTSi and Ungle-Bnd kruTSi, Puiei, Aedeitrani, PcfyIlei on Road, PcfyIlei on s roii walS)

Cl Movementi

ID: 1072489, LoTatcon: 71.628177, -83.608756



Aroved by: s reghton Manning  
Engineering, LLA  
2 Wanneri s r'le,  
Clbany, NY, 12205, BU

Leg DreTcon	Eait MarSet Ut Eaitbound						Eait MarSet Ut Weitbound						Mulberry Ut Northbound						Mulberry Ut Uouthbound						Int
	L	k	R	B	Cpp	Aed*	L	k	R	B	Cpp	Aed*	L	k	R	B	Cpp	Aed*	L	k	R	B	Cpp	Aed*	
2023-03-01 7:00AM	1	34	0	0	36	1	0	34	4	0	79	0	9	4	1	0	15	0	4	3	9	0	18	3	118
7:15AM	9	77	0	0	50	2	0	33	8	0	70	0	9	0	3	0	6	1	7	0	9	0	10	2	106
7:30AM	3	75	0	0	74	0	2	34	5	0	75	0	5	4	0	0	13	0	8	2	0	0	6	1	115
7:45AM	7	32	1	0	38	0	1	39	5	0	72	0	7	7	1	0	6	0	4	5	7	0	18	0	105
Hourly kotal	17	156	1	0	187	3	3	175	25	0	183	0	21	20	5	0	79	1	28	10	19	0	53	9	779
5:00AM	5	51	3	0	56	0	2	32	2	0	39	1	4	10	2	0	20	1	10	0	2	0	12	1	128
5:15AM	7	39	1	0	71	0	1	26	6	0	36	0	4	7	1	0	13	1	4	1	5	0	17	1	108
5:30AM	0	24	2	0	30	0	1	20	2	0	23	0	7	9	3	0	13	1	4	5	5	0	14	0	47
5:45AM	0	28	0	0	28	1	2	26	9	0	38	0	5	3	0	0	4	3	2	9	7	0	12	0	47
Hourly kotal	6	172	9	0	158	1	9	110	16	0	135	1	25	23	9	0	57	9	24	12	19	0	59	2	702
kotal	23	301	8	0	331	7	6	255	77	0	304	1	79	73	11	0	100	8	55	22	32	0	106	4	474
% CpproaTh	9.6%	60.6%	2.1%	0%	-	-	2.6%	42.4%	17.3%	0%	-	-	79.0%	73.0%	11.0%	0%	-	-	50.5%	20.2%	26.7%	0%	-	-	-
% kotal	2.8%	35.5%	0.4%	0%	36.0%	-	1.1%	30.1%	5.2%	0%	39.3%	-	5.7%	5.1%	1.3%	0%	11.4%	-	9.5%	2.9%	3.4%	0%	12.6%	-	-
Lghti	22	269	8	0	325	-	6	276	77	0	302	-	75	73	11	0	66	-	57	22	31	0	108	-	433
% Lghti	65.8%	64.3%	100%	0%	64.2%	-	100%	68.9%	100%	0%	64.1%	-	68.4%	100%	100%	0%	66.0%	-	64.2%	100%	69.6%	0%	64.2%	-	64.2%
Crtcfiluted kruTSi and Ungle-Bnd kruTSi	1	7	0	0	5	-	0	5	0	0	5	-	1	0	0	0	1	-	0	0	1	0	1	-	12
% Crtcfiluted kruTSi and Ungle-Bnd kruTSi	7.3%	1.3%	0%	0%	1.5%	-	0%	2.0%	0%	0%	1.9%	-	2.2%	0%	0%	0%	1.0%	-	0%	0%	3.1%	0%	0.6%	-	1.7%
Puiei	0	1	0	0	1	-	0	0	0	0	0	-	0	0	0	0	0	-	1	0	0	0	1	-	2
% Puiei	0%	0.3%	0%	0%	0.3%	-	0%	0%	0%	0%	0%	-	0%	0%	0%	0%	0%	-	1.4%	0%	0%	0%	0.6%	-	0.2%
PcfyIlei on Road	0	0	0	0	0	-	0	1	0	0	1	-	0	0	0	0	0	-	0	0	0	0	0	-	1
% PcfyIlei on Road	0%	0%	0%	0%	0%	-	0%	0.7%	0%	0%	0.3%	-	0%	0%	0%	0%	0%	-	0%	0%	0%	0%	0%	-	0.1%
Aedeitrani	-	-	-	-	-	7	-	-	-	-	-	1	-	-	-	-	-	8	-	-	-	-	-	4	-
% Aedeitrani	-	-	-	-	-	100%	-	-	-	-	-	100%	-	-	-	-	-	100%	-	-	-	-	-	100%	-
PcfyIlei on s roii walS	-	-	-	-	-	0	-	-	-	-	-	0	-	-	-	-	-	0	-	-	-	-	-	0	-
% PcfyIlei on s roii walS	-	-	-	-	-	0%	-	-	-	-	-	0%	-	-	-	-	-	0%	-	-	-	-	-	0%	-

\*Aedeitrani and PcfyIlei on s roii walS. L: Left, R: Rqht, k: khru, B: B-kurn





East Market Street-Mulberry Street Weekday PM - TMC

Wed Mar 1, 2023

AM AeaP k(7: AM - : 7: AM8-) QerawAeaP1 Hbr

u wCvasses kLights, u rticovated TrocPs and Singe-Unit TrocPs, Boses, Aedestrians, Bicycves H RHhd, Bicycves H CrHswaP8

u wMHDelements

ID710(249. , LHcatiH7(16291((, -93609(: 5



ArHQed by7CreightH Manning  
Engineering, LLA  
2 Winners Circve,  
u vbany, NY, 1220: , US

Leg DirectiH	East MarPet St EastbHnd						East MarPet St WestbHnd						Mowberry St NHthbHnd						Mowberry St SHthbHnd						Int		
Time	L	T	R	U	u pp	Aed*	L	T	R	U	u pp	Aed*	L	T	R	U	u pp	Aed*	L	T	R	U	u pp	Aed*	Int		
2023-03-01 (7: AM	.	(	0	0	:0	2	0	33	9	0	(0	0	.	0	3	0	5	1	(	0	.	0	10	2	105		
(730AM	3	(	0	0	(4	0	2	34	:	0	(:	0	:	4	0	0	13	0	9	2	0	0	5	1	11:		
(7: AM	(	32	1	0	39	0	1	3.	:	0	(2	0	(	(	1	0	5	0	4	:	(	0	19	0	10:		
:700AM	:	:1	3	0	:5	0	2	32	2	0	3.	1	4	10	2	0	20	1	10	0	2	0	12	1	129		
<b>THav</b>	14	192	(	0	15(	2	:	135	15	0	1.3	1	23	22	.	0	:1	2	25	9	12	0	(4	(	(:.		
<b>% u pprHch</b>	56%	44%	26%	0%	-	-	36%	4%	6%	11%	0%	-	-	(:	6%	(36%	11%	0%	-	-	.06%	1(6%	2:	6%	0%	-	-
<b>% THav</b>	36%	39%	06%	0%	(26%	-	16%	306%	(62%	0%	3:6%	-	:6%	(6%	16%	0%	116%	-	.6%	16%	26%	0%	106%	-	-		
<b>Al F</b>	06:0	06(3	0633	-	0622	-	062:	061(	0695	-	060.	-	0615	06:0	0600	-	0634	-	062:	06:	0600	-	060.	-	0654		
<b>Lights</b>	19	1.5	(	0	150	-	:	13(	15	0	1:4	-	22	22	.	0	:0	-	25	9	11	0	(9	-	((:		
<b>% Lights</b>	5(6%	546%	100%	0%	596%	-	100%	5.6%	100%	0%	5.6%	-	5:6%	100%	100%	0%	546%	-	100%	100%	516%	0%	596%	-	596%		
<b>u rticovated TrocPs and Singe-Unit TrocPs</b>	1	3	0	0	(	-	0	:	0	0	:	-	1	0	0	0	1	-	0	0	1	0	1	-	11		
<b>% u rticovated TrocPs and Singe-Unit TrocPs</b>	:6%	16%	0%	0%	26%	-	0%	36%	0%	0%	36%	-	(6%	0%	0%	0%	26%	-	0%	0%	46%	0%	26%	-	26%		
<b>Boses</b>	0	0	0	0	0	-	0	0	0	0	0	-	0	0	0	0	0	-	0	0	0	0	0	-	0		
<b>% Boses</b>	0%	0%	0%	0%	0%	-	0%	0%	0%	0%	0%	-	0%	0%	0%	0%	0%	-	0%	0%	0%	0%	0%	-	0%		
<b>Bicycves H RHhd</b>	0	0	0	0	0	-	0	0	0	0	0	-	0	0	0	0	0	-	0	0	0	0	0	-	0		
<b>% Bicycves H RHhd</b>	0%	0%	0%	0%	0%	-	0%	0%	0%	0%	0%	-	0%	0%	0%	0%	0%	-	0%	0%	0%	0%	0%	-	0%		
<b>Aedestrians</b>	-	-	-	-	-	2	-	-	-	-	-	1	-	-	-	-	-	2	-	-	-	-	-	(			
<b>% Aedestrians</b>	-	-	-	-	-	100%	-	-	-	-	-	100%	-	-	-	-	-	100%	-	-	-	-	-	100%			
<b>Bicycves H CrHswaP</b>	-	-	-	-	-	0	-	-	-	-	-	0	-	-	-	-	-	0	-	-	-	-	-	0			
<b>% Bicycves H CrHswaP</b>	-	-	-	-	-	0%	-	-	-	-	-	0%	-	-	-	-	-	0%	-	-	-	-	-	0%			

\* Aedestrians and Bicycves H CrHswaP6L7Left, R7Right, T7Thro, U7U-Torn

East Market Street-Mulberry Street Weekday PM - TMC

Wed Mar 1, 2023

AM AeaP k 7l: AM - : 7l: AM8- ) CerawAeaP1 Hbr

u wCvases kLlights, u rticovated TrocPs and Singv-Unit TrocPs, Boses, Aedestrians, Bicycves  
Hh RHhd, Bicycves Hh CrHswwvP8

u wMHDelements

ID710(249. , LHatiHh7( 16291( ( , -93609( : 5



ArHQded by7CreightH Manning  
Engineering, LLA  
2 Winners Cirve,  
u vbany, NY, 1220: , US

[N] Mulberry St

Total: 218

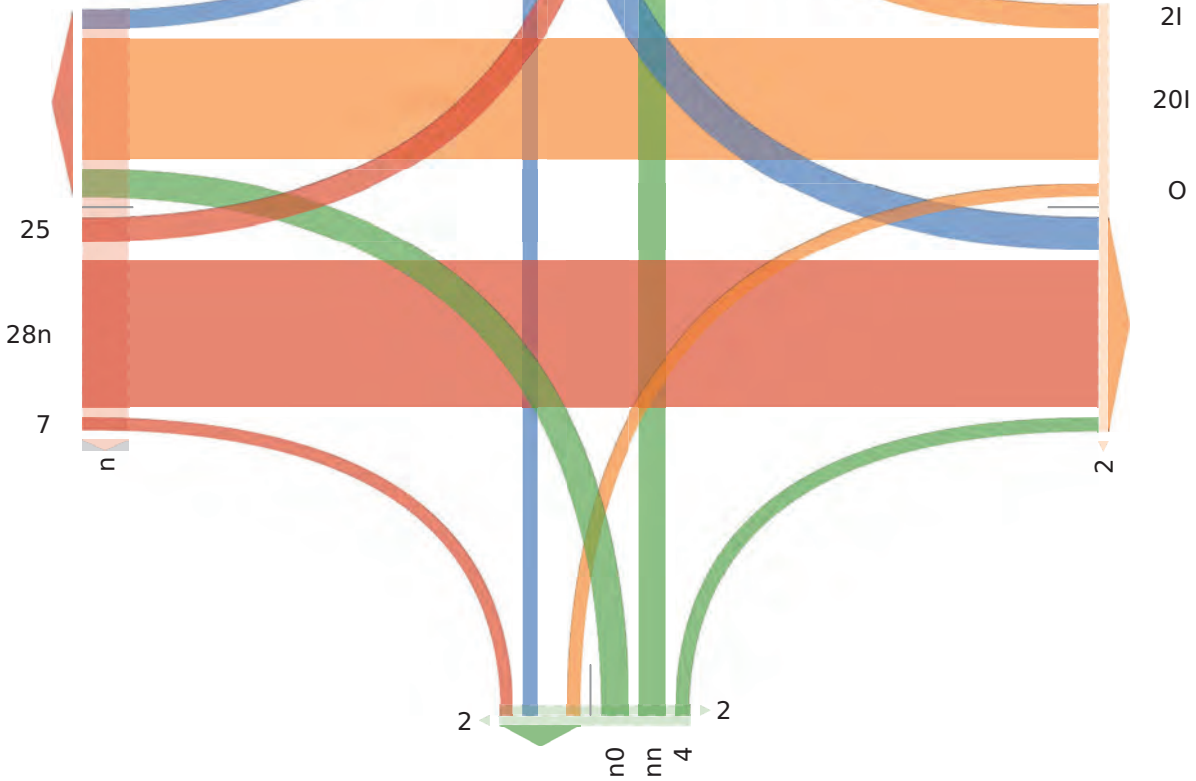
8: 75 6 ut: 01

2n 8 n



[W] East Market St

Total: 045  
8: 217 6 ut: 287



6 ut: n18  
Total: 081  
[E] East Market St

6 ut: 24 8: 02  
Total: 48

[S] Mulberry St

South Street-Mulberry Street Weekday PM - TMC

Wed Mar 1, 2023

Full Length (7 AM-9 AM)

Cll s lai iei (Lqhti, Crtfūlateg kruTSi and Ungle-Bnd kruTSi, Pui ei, Aedei trani, P cŷŷIlei on Road, P cŷŷIlei on s roi i wals)

Cll Movementi

ID: 1072442, LoTatcon: 718 29016, -538 05371



Provided by: s reghon Mannng  
Engineering, LLA  
2 Wanneri s aŷŷe,  
Clbany, NY, 12206, BU

Leg Dreŷŷon	Uouth Ut Eaitbound					Uouth Ut Wei tbound					Mulberry Ut Uouthbound					Int
	L	k	B	Cpp	Aed*	k	R	B	Cpp	Aed*	L	R	B	Cpp	Aed*	
kane																
2023-03-01 7:00AM	0	5	0	5	0	4	17	0	22	0	3	0	0	3	0	32
7:16AM	7	12	0	19	0	4	5	0	16	0	0	0	0	0	0	31
7:30AM	0	5	0	5	0	6	13	0	14	0	3	0	0	3	3	24
7:76AM	0	6	1	9	0	.	13	0	22	0	6	0	0	6	0	33
Hourly kotal	7	31	1	39	0	30	75	0	55	0	11	0	0	11	3	127
6:00AM	2	10	0	12	0	5	17	0	21	0	1	2	0	3	1	39
6:16AM	0	5	0	5	0	5	13	0	20	0	2	1	0	3	3	30
6:30AM	1	11	0	12	0	6	12	0	15	0	6	1	0	9	3	36
6:76AM	0	4	0	4	0	7	6	0	.	0	2	1	0	3	0	20
Hourly kotal	3	39	0	3.	0	23	77	0	95	0	10	6	0	16	5	121
<b>kotal</b>	5	95	1	56	0	63	.1	0	177	0	21	6	0	29	10	276
<b>% Cpproaŷh</b>	.8%	4.8%	18%	-	-	39%	93%	0%	-	-	40%	1.8%	0%	-	-	-
<b>% kotal</b>	28%	258%	08%	308%	-	218%	358%	0%	648%	-	48%	28%	0%	108%	-	-
<b>Lqhti</b>	5	96	1	53	-	61	.0	0	171	-	21	6	0	29	-	270
<b>% Lqhti</b>	100%	.58%	100%	.58%	-	.98%	.48%	0%	.58%	-	100%	100%	0%	100%	-	.48%
<b>Crtfūlateg kruTSi and Ungle-Bnd kruTSi</b>	0	0	0	0	-	1	1	0	2	-	0	0	0	0	-	2
<b>% Crtfūlateg kruTSi and Ungle-Bnd kruTSi</b>	0%	0%	0%	0%	-	18%	18%	0%	18%	-	0%	0%	0%	0%	-	08%
<b>Pui ei</b>	0	1	0	1	-	1	0	0	1	-	0	0	0	0	-	2
<b>% Pui ei</b>	0%	18%	0%	18%	-	18%	0%	0%	08%	-	0%	0%	0%	0%	-	08%
<b>P cŷŷIlei on Road</b>	0	1	0	1	-	0	0	0	0	-	0	0	0	0	-	1
<b>% P cŷŷIlei on Road</b>	0%	18%	0%	18%	-	0%	0%	0%	0%	-	0%	0%	0%	0%	-	08%
<b>Aedei trani</b>	-	-	-	-	0	-	-	-	-	0	-	-	-	-	10	-
<b>% Aedei trani</b>	-	-	-	-	-	-	-	-	-	-	-	-	-	-	100%	-
<b>P cŷŷIlei on s roi i wals</b>	-	-	-	-	0	-	-	-	-	0	-	-	-	-	0	-
<b>% P cŷŷIlei on s roi i wals</b>	-	-	-	-	-	-	-	-	-	-	-	-	-	-	0%	-

\* Aedei trani and P cŷŷIlei on s roi i wals: L: Left, R: Rqht, k: khru, B: B-kurn



South Street-Mulberry Street Weekday PM - TMC

Wed Mar 1, 2023

AM AeaP k (7: AM - : 7: AM8-) OerawAeaP l Hbr

u wCvasses kLlights, u rticovated TrocPs and Singe-Unit TrocPs, Boses, Aedestrians, Bicycves Hh RHhd, Bicycves Hh CrHswaP8

u wMHDelements

ID710(2442, LHcatiHh7(19 2601: , -539 053(1



ArHQided by7CreightH Manning  
Engineering, LLA  
2 Winners Circv,  
u vbany, NY, 1220: , US

Leg DirectiHh	SHhth St EastbHhnd					SHhth St WestbHhnd					Movberry St SHhthbHhnd					Int
	L	T	U	u pp	Aed*	T	R	U	u pp	Aed*	L	R	U	u pp	Aed*	
2023-03-01 (7: AM	0	:	1	6	0	.	13	0	22	0	:	0	0	:	0	33
: 700AM	2	10	0	12	0	5	1	0	21	0	1	2	0	3	1	36
: 7: AM	0	5	0	5	0	5	13	0	20	0	2	1	0	3	3	30
: 730AM	1	11	0	12	0	:	12	0	15	0	:	1	0	6	3	3:
<b>THav</b>	3	33	1	35	0	24	:	2	40	0	13	(	0	15	5	13(
<b>% u pprHhch</b>	49%	4.9%	25%	-	-	3.9%	6.9%	0%	-	-	56%	23%	0%	-	-	-
<b>% THav</b>	29%	2(9%	05%	25%	-	20%	34%	0%	:.9%	-	.9%	39%	0%	12%	-	-
<b>Al F</b>	095:	05: 0	02: 0	0551	-	0954	09 2.	-	09 0.	-	096: 0	09 00	-	0504	-	09 31
<b>Lights</b>	3	33	1	35	-	25	:	2	5.	-	13	(	0	15	-	133
<b>% Lights</b>	100%	100%	100%	100%	-	.69%	100%	0%	.49%	-	100%	100%	0%	100%	-	..9%
<b>u rticovated TrocPs and Singe-Unit TrocPs</b>	0	0	0	0	-	1	0	0	1	-	0	0	0	0	-	1
<b>% u rticovated TrocPs and Singe-Unit TrocPs</b>	0%	0%	0%	0%	-	39%	0%	0%	19%	-	0%	0%	0%	0%	-	05%
<b>Boses</b>	0	0	0	0	-	0	0	0	0	-	0	0	0	0	-	0
<b>% Boses</b>	0%	0%	0%	0%	-	0%	0%	0%	0%	-	0%	0%	0%	0%	-	0%
<b>Bicycves Hh RHhd</b>	0	0	0	0	-	0	0	0	0	-	0	0	0	0	-	0
<b>% Bicycves Hh RHhd</b>	0%	0%	0%	0%	-	0%	0%	0%	0%	-	0%	0%	0%	0%	-	0%
<b>Aedestrians</b>	-	-	-	-	0	-	-	-	-	0	-	-	-	-	-	5
<b>% Aedestrians</b>	-	-	-	-	-	-	-	-	-	-	-	-	-	-	100%	-
<b>Bicycves Hh CrHswaP</b>	-	-	-	-	0	-	-	-	-	0	-	-	-	-	-	0
<b>% Bicycves Hh CrHswaP</b>	-	-	-	-	-	-	-	-	-	-	-	-	-	-	0%	-

\* Aedestrians and Bicycves Hh CrHswaP9L7Left, R7Right, T7Thro, U7U-Torn

South Street-Mulberry Street Weekday PM - TMC

Wed Mar 1, 2023

AM AeaP k ( : AM - : : AM8- ) CerawAeaP1 Hbr

u wCvasses kLlights, u rticovated TrocPs and Singv-Unit TrocPs, Boses, Aedestrians, Bicycves  
Hh RHhd, Bicycves Hh CrHswwvP8

u wMHDelements

ID710(2442, LHatiHh7(19 2601: , -539 053(1



ArHQded by7CreightH Manning  
Engineering, LLA  
2 Winners Cirve,  
u vbany, NY, 1220: , US

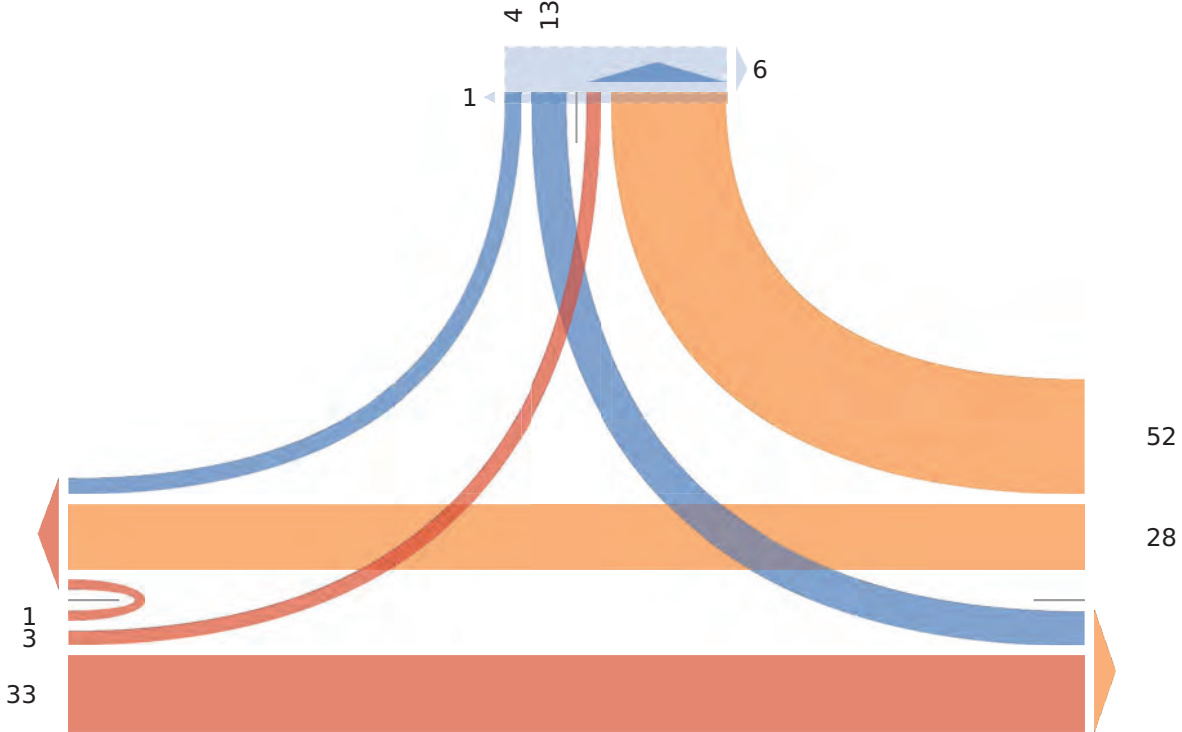
[N] Mulberry St

Total: 72

In: 17 Out: 55

4 13  
1 6

[W] South St  
Total: 70  
In: 37 Out: 33



East Market Street-Mulberry Street Saturday ... - TMC

Wed Mar 1, 21013

M Full aLnđ thh ( 7 A - 7 9

( u) ueCāCtI sngđC2( idcFueđTkiFcSCeLT WLnuaAULsđkiFcSC2BFGāC2- aTađseLC2BscPcuaCyL

o yeT2BscPcuaCyL) iyCReuS9

( u7 ywāv aLđC

nh Dh0: 148821 ycedyLD h.618h: : 2A3.608: , 6



- iywTaTr PD) iasngđyL 7 eLLsLn

5 LnsLaaisLn2l l -

1 b sLLaiC) sicua2

( ureLP2EN2h110, 2UW

l an l siacđyL	5eđ7 eiSadVđ 5eđ7 yFLT	5eđ7 eiSadVđ b ađ7 yFLT	7 FuraiP Vđ EyiđryFLT	7 FuraiP Vđ W FđryFLT	
ksv a	l k o U ( YY - aTp	l k o U ( YY - aTp	l k o U ( YY - aTp	l k o U ( YY - aTp	nd
1013A1A, hhĐ0( 7	h 1* 0 0 18	h 0 14 8 0 3, 0	, h 0 0 * h	1 0 3 0 , 0	83
hhĐ, ( 7	, 30 0 0 3, h	0 13 : 0 18 0	1 h 0 0 3 h	3 h 3 0 8 h	81
hhĐ0( 7	h h4 0 0 h6 0	h 33 * 0 : 0 0	3 3 0 0 * h	3 0 h 0 : 0	*6
hhĐ, ( 7	1 31 0 0 3: 0	0 34 3 0 : h 0	h , h 0 8 0	* h 0 0 8 0	46
HyFiP kyđu	6 h0* 0 0 hh,	1 h h11 10 0 h: 3 0	hh h0 h 0 11 3	h: 1 8 0 13 h	303
h1Đ0- 7	1 14 h 0 3h 0	1 1, : 0 3h 0	4 : h 0 h3 0	* 3 , 0 h: 0	46
h1Đ, - 7	, : 0 1 0 : 8 0	0 3h , 0 3* 0	: 0 h 0 , h	, h 1 0 4 h	6*
h1Đ0- 7	3 1* 0 0 16 0	0 38 1 0 36 0	1 1 1 0 * 0	3 0 h 0 : h	84
h1Đ, - 7	0 10 h 0 1h 0	0 31 3 0 3, 0	0 h 0 0 h 0	, h : 0 h0 0	*8
HyFiP kyđu	h0 hh: : 0 h14 0	1 h1, h: 0 h: h 0	h: 8 : 0 1, h	h6 , h1 0 3* 1	330
hĐ0- 7	1 31 0 0 3: 0	0 33 * 0 36 0	1 1 0 0 : 0	, 1 h 0 4 0	4,
hĐ, - 7	1 : 0 : 0 : * 0	h 3h h 0 33 0	1 1 0 0 : h	, h , 0 hh 0	6:
hĐ0- 7	3 31 0 0 3, 0	h : 0 1 0 : 3 0	, , h 0 hh 0	, : 1 0 hh 0	h00
hĐ, - 7	h 3: 0 0 3, 0	h 36 1 0 : 1 0	h 4 0 0 6 3	8 : 8 0 h4 0	h0:
HyFiP kyđu	4 h34 : 0 h, 0 0	3 h: 3 hh 0 h, 8 0	h0 h8 h 0 14 :	11 hh h, 0 : 4 0	343
hĐ0- 7	0 0 0 0 0 0	0 0 0 0 0 0	0 0 0 0 0 0	0 0 0 0 0 0	0
HyFiP kyđu	0 0 0 0 0 0	0 0 0 0 0 0	0 0 0 0 0 0	0 0 0 0 0 0	0
kyđu	18 3,4 4 0 363	1 * 360 : , 0 :: h 0	3, 3: * 0 8, 4	,, h4 3: 0 h08 3	h0h*
% ( Yiyecg	*.6% 6h.% 1.0% 0% A	A h: % 44: % h0.1% 0% A	A: *.8% : ,.3% 4.0% 0% A	A, h: % h*.4% 3h.4% 0% A	A A
% kyđu	1.8% 3, .1% 0.4% 0% 34.8%	A 0.*% 34: % : : % 0% : 3: %	A 3: % 3.3% 0.*% 0% 8: %	A , : % h.4% 3.3% 0% h0., %	A A
l sngđC	18 3: : * 0 388	A * 38: : : 0 : 1: A	A 3, 3: * 0 8, A	A , : h4 3: 0 h0* A	A 641
% l sngđC	h00% 6*.h% 8, .0% 0% 6, .6%	A h00% 6, .6% 68.4% 0% 6*.h%	A h00% h00% h00% 0% h00%	A 64.1% h00% h00% 0% 66.h%	A 6*.8%
( idcFueđTkiFcSCeLT WLnuaAULsđkiFcSC	0 h: 1 0 h*	A 0 h* h 0 h8	A 0 0 0 0 0	A h 0 0 0 h	A 3:
%( idcFueđTkiFcSCeLT WLnuaAULsđkiFcSC	0% 3.6% 1, .0% 0% :.h%	A 0% :.h% 1.1% 0% 3.6%	A 0% 0% 0% 0% 0%	A h.4% 0% 0% 0% 0.6%	A 3.3%
BFGāC	0 0 0 0 0	A 0 0 0 0 0	A 0 0 0 0 0	A 0 0 0 0 0	A 0
% BFGāC	0% 0% 0% 0% 0%	A 0% 0% 0% 0% 0%	A 0% 0% 0% 0% 0%	A 0% 0% 0% 0% 0%	A 0%
BscPcuaCyL o yeT	0 0 0 0 0	A 0 0 0 0 0	A 0 0 0 0 0	A 0 0 0 0 0	A 0
% BscPcuaCyL o yeT	0% 0% 0% 0% 0%	A 0% 0% 0% 0% 0%	A 0% 0% 0% 0% 0%	A 0% 0% 0% 0% 0%	A 0%
- aTađseLC	A A A A A 1	A A A A A 0	A A A A A 4	A A A A A 3	
% - aTađseLC	A A A A Ah00%	A A A A A Ah00%	A A A A Ah00%	A A A A Ah00%	A
BscPcuaCyL) iyCReuS	A A A A A 0	A A A A A 0	A A A A A 0	A A A A A 0	
% BscPcuaCyL) iyCReuS	A A A A A 0%	A A A A A 0%	A A A A A 0%	A A A A A 0%	A

P- aTađseLCeLT BscPcuaCyL) iyCReuS. l Dl afđo Db sngđk Dk gi F2UDUđk FiL

East Market Street-Mulberry Street Saturday ... - TMC

Wed Mar 1, 21013

M Full a Lndg thh ( 7 A - 7 9

( u) ueCCaCtI sngdC( i dcFuedT kiFcSCeLT WLnuaAULsdiFcSC2BFGaC2- aTaCtseLC2BscPcuac  
yLo yeT2BscPcuCyL) iyCCRet69

( u7 ywav aLdC

nh Dh0: 14882l ycedyLD h.518h: : 2A3.508: , 5



- iywTaTr PD) iasngdL7 eLLsLn  
bLnsLaaisLn2l l -  
1 E sLLaiC) sicua2  
( u r eLP2NY2h110, 2UW

[N] Mulberry St

Total: 218

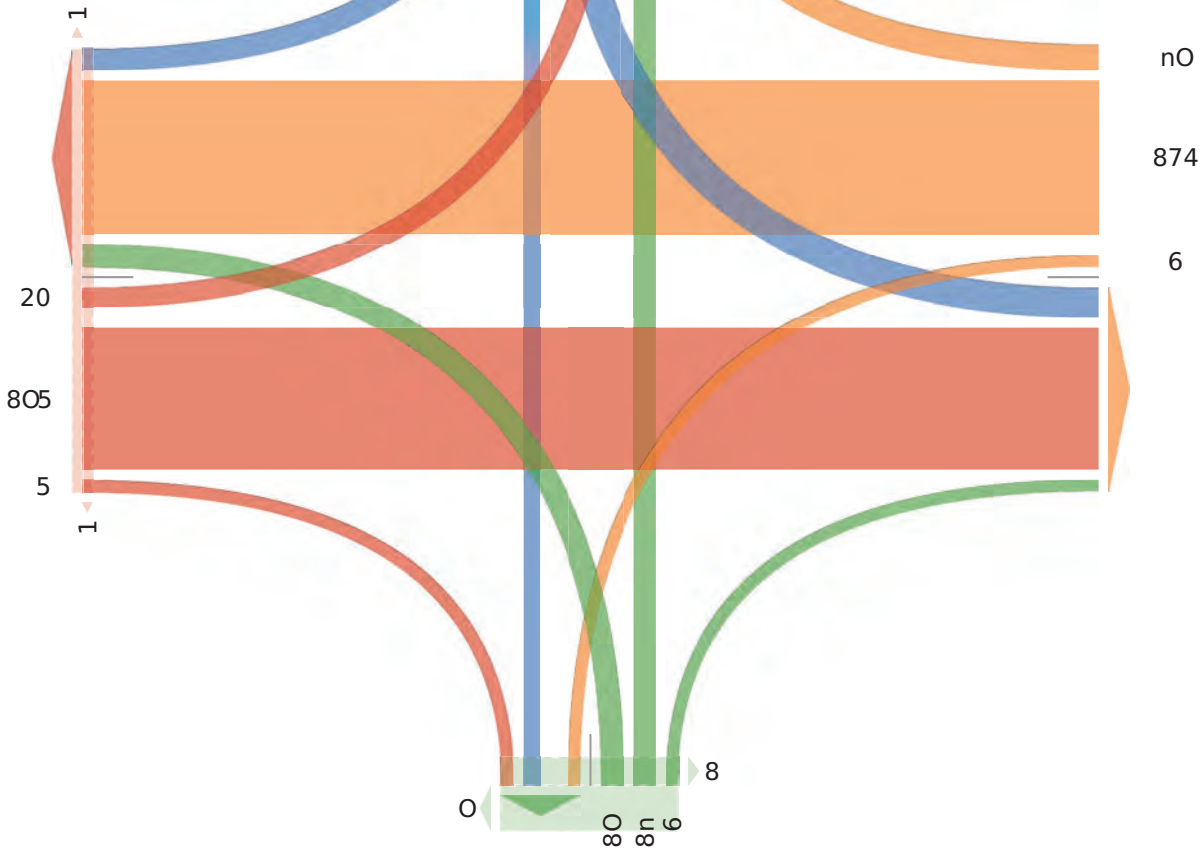
8: 140 I ut: 146

8n 15 0

1 2

[W] East Market St

Total: 502 I ut: n07  
8: 878



I ut: 82 8: 00

Total: 140

[S] Mulberry St



East Market Street-Mulberry Street Saturday ... - TMC

Sat Feb 25, 2023

Midday Peak (WKND), PM Peak (WKND) (1 PM - 2 PM) - Overall Peak Hour

All Classes (Lights, Articulated Trucks and Single-Unit Trucks, Buses, Pedestrians, Bicycles on Road, Bicycles on Crosswalk)

All Movements

ID: 1042877, Location: 41.927144, -73.907459



Provided by: Creighton Manning  
Engineering, LLP  
2 Winners Circle,  
Albany, NY, 12205, US

Leg Direction	East Market St Eastbound					East Market St Westbound					Mulberry St Northbound					Mulberry St Southbound					Int					
	L	T	R	U	App Ped*	L	T	R	U	App Ped*	L	T	R	U	App Ped*	L	T	R	U	App Ped*						
2023-02-25 1:00PM	2	32	0	0	34	0	0	33	6	0	39	0	2	2	0	0	4	0	5	2	1	0	8	0	85	
1:15PM	2	40	4	0	46	0	1	31	1	0	33	0	2	2	0	0	4	1	5	1	5	0	11	0	94	
1:30PM	3	32	0	0	35	0	1	40	2	0	43	0	5	5	1	0	11	0	5	4	2	0	11	0	100	
1:45PM	1	34	0	0	35	0	1	39	2	0	42	0	1	8	0	0	9	3	7	4	7	0	18	0	104	
<b>Total</b>	8	138	4	0	150	0	3	143	11	0	157	0	10	17	1	0	28	4	22	11	15	0	48	0	383	
<b>% Approach</b>	5.3%	92.0%	2.7%	0%	-	-	1.9%	91.1%	7.0%	0%	-	-	35.7%	60.7%	3.6%	0%	-	-	45.8%	22.9%	31.3%	0%	-	-	-	
<b>% Total</b>	2.1%	36.0%	1.0%	0%	39.2%	-	0.8%	37.3%	2.9%	0%	41.0%	-	2.6%	4.4%	0.3%	0%	7.3%	-	5.7%	2.9%	3.9%	0%	12.5%	-	-	
<b>PHF</b>	0.667	0.863	0.250	-	0.815	-	0.750	0.894	0.458	-	0.913	-	0.500	0.531	0.250	-	0.636	-	0.786	0.688	0.536	-	0.667	-	0.921	
<b>Lights</b>	8	134	2	0	144	-	3	137	11	0	151	-	10	17	1	0	28	-	22	11	15	0	48	-	371	
<b>% Lights</b>	100%	97.1%	50.0%	0%	96.0%	-	100%	95.8%	100%	0%	96.2%	-	100%	100%	100%	0%	100%	-	100%	100%	100%	0%	100%	-	96.9%	
<b>Articulated Trucks and Single-Unit Trucks</b>	0	4	2	0	6	-	0	6	0	0	6	-	0	0	0	0	0	-	0	0	0	0	0	0	-	12
<b>% Articulated Trucks and Single-Unit Trucks</b>	0%	2.9%	50.0%	0%	4.0%	-	0%	4.2%	0%	0%	3.8%	-	0%	0%	0%	0%	0%	-	0%	0%	0%	0%	0%	0%	-	3.1%
<b>Buses</b>	0	0	0	0	0	-	0	0	0	0	0	-	0	0	0	0	0	-	0	0	0	0	0	0	-	0
<b>% Buses</b>	0%	0%	0%	0%	0%	-	0%	0%	0%	0%	0%	-	0%	0%	0%	0%	0%	-	0%	0%	0%	0%	0%	0%	-	0%
<b>Bicycles on Road</b>	0	0	0	0	0	-	0	0	0	0	0	-	0	0	0	0	0	-	0	0	0	0	0	0	-	0
<b>% Bicycles on Road</b>	0%	0%	0%	0%	0%	-	0%	0%	0%	0%	0%	-	0%	0%	0%	0%	0%	-	0%	0%	0%	0%	0%	0%	-	0%
<b>Pedestrians</b>	-	-	-	-	-	0	-	-	-	-	-	0	-	-	-	-	-	4	-	-	-	-	-	-	0	-
<b>% Pedestrians</b>	-	-	-	-	-	-	-	-	-	-	-	-	-	-	-	-	-	100%	-	-	-	-	-	-	-	-
<b>Bicycles on Crosswalk</b>	-	-	-	-	-	0	-	-	-	-	-	0	-	-	-	-	-	0	-	-	-	-	-	-	0	
<b>% Bicycles on Crosswalk</b>	-	-	-	-	-	-	-	-	-	-	-	-	-	-	-	-	-	0%	-	-	-	-	-	-	-	

\*Pedestrians and Bicycles on Crosswalk. L: Left, R: Right, T: Thru, U: U-Turn

East Market Street-Mulberry Street Saturday ... - TMC

Sat Feb 25, 2023

Midday Peak (WKND), PM Peak (WKND) (1 PM - 2 PM) - Overall Peak Hour

All Classes (Lights, Articulated Trucks and Single-Unit Trucks, Buses, Pedestrians, Bicycles on Road, Bicycles on Crosswalk)

All Movements

ID: 1042877, Location: 41.927144, -73.907459



Provided by: Creighton Manning Engineering, LLP  
2 Winners Circle,  
Albany, NY, 12205, US

[N] Mulberry St

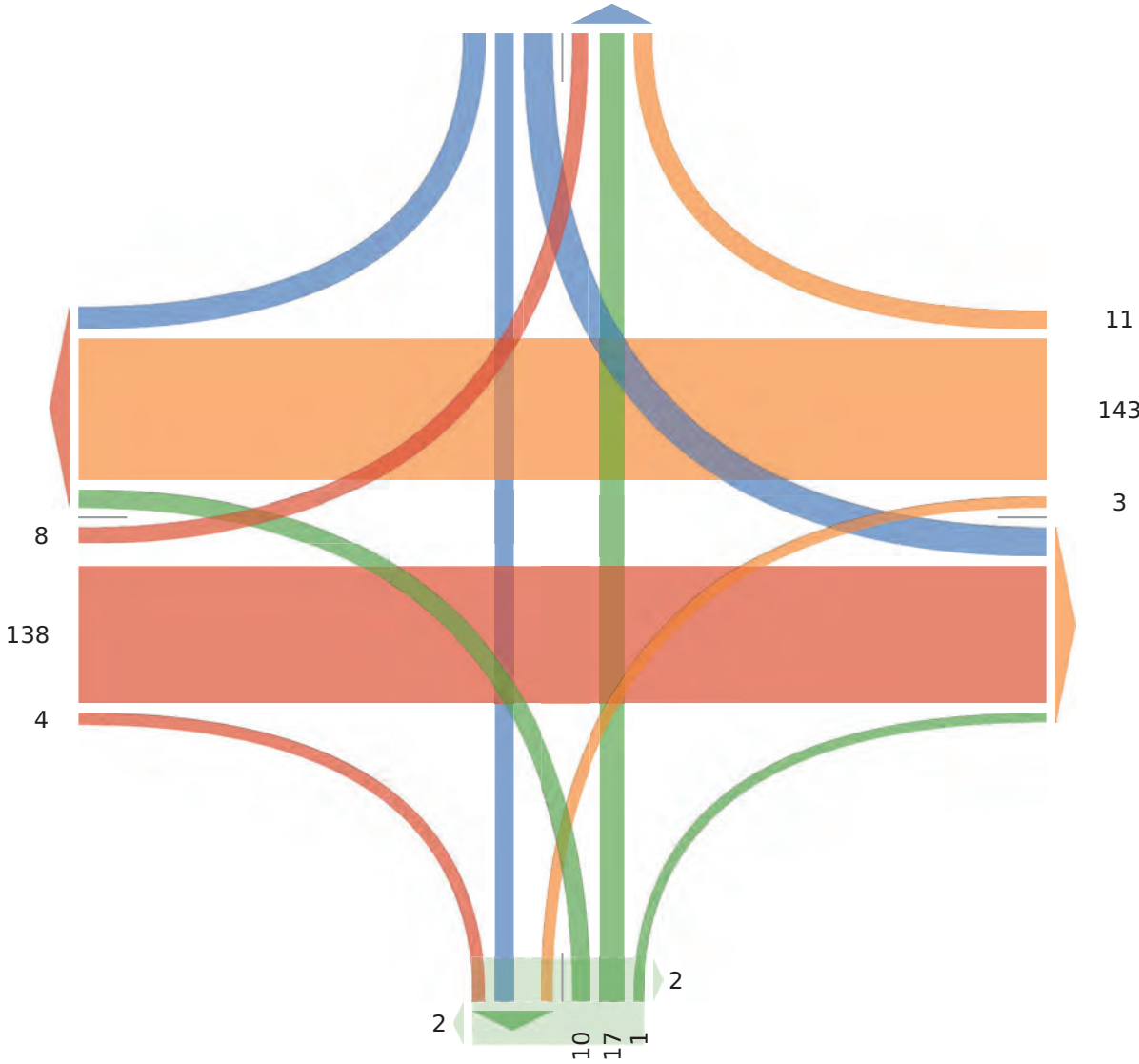
Total: 84

In: 48 Out: 36

15 11 22

[W] East Market St

Total: 318  
In: 150 Out: 168



Out: 18 In: 28

Total: 46

[S] Mulberry St

South Street-Mulberry Street Saturday Midday - TMC

Wed Mar 1, 21013

M Full a Lndg thh ( 7 A - 7 9

( u) uCaCtI sngC2( idcFuedTkiFcSCeLT WLnuaAULsikiFcSC2BFGaC2- aTaGdseLC2BscPcuC  
yLo yeT2BscPcuCyL) iyCRetS9

( u7 ywav aLdC

nh Dh0: 144: 2l ycedyLD: h8 160h, 2A538 053: h



- iywTaTrPD) iasngyL 7 eLLsLn  
bLnsLaaisLn2l l -  
1 E sLLaiC) sicua2  
( ur eLP2NY2h110, 2UW

l an I siacdyL	WyFqg Wl beGryFLT	WyFqg Wl E aGryFLT	7 FuraiiP Wl WyFqgryFLT	
k s v a	l k U ( pp - aT*	k o U ( pp - aT*	l o U ( pp - aT*	nd
1013A1A, hhD0( 7	h 4 0 . 0	: : 0 4 0	h h 0 1 h	h.
hhD, ( 7	h 5 0 4 0	h: 1 0 h6 0	h 0 0 h 0	1,
hhB0( 7	0 : 0 : 0	4 6 0 h: 0	h h 0 1 h	10
hhD, ( 7	h , 0 6 0	hh 6 0 h5 0	0 h 0 h 0	1:
HyFiUP kydu	3 1: 0 15 0	35 h4 0 ,, 0	3 3 0 6 1	44
h1D0-7	0 6 0 6 0	3 h1 0 h, 0	: 1 h 5 h	14
h1D, -7	0 . 0 . 0	3 , 0 4 0	3 0 0 3 0	10
h1B0-7	1 3 0 , 0	3 : 0 5 0	0 0 0 0 0	h1
h1D, -7	0 6 0 6 0	3 h 0 : 0	1 0 0 1 0	h1
HyFiUP kydu	1 1: 0 16 0	h1 11 0 3: 0	. 1 h h1 h	51
hD0-7	0 0 0 0 0	5 : 0 hh 0	1 0 0 1 0	h3
hD, -7	0 : 0 : 0	3 : 0 5 0	3 h 0 : ,	h,
hB0-7	h . 0 h0 0	: hh 0 h, 0	6 0 0 6 0	3h
hD, -7	h 6 0 5 0	4 h0 0 h4 0	: 0 0 0 : 0	1.
HyFiUP kydu	1 h. 0 1h 0	11 1. 0 , h 0	h, h 0 h6 ,	44
kydu	5 65 0 5: 0	5h 6. 0 h: 0 0	15 6 h 3: 4	1: 4
% ( ppiyecg	. 8 % . 08 % 0% A	, 08% : . 8% 0% A	5. 8 % h58% 18 % A	A A A
% kydu	18% 158% 0% 1. 8%	148% 158% 0% , 68 %	h08 % 18 % 08 % h38%	A A A
l sngC	5 66 0 53	50 64 0 h34	16 6 h 33	A A 1: :
% l sngC	h00% . 48 % 0% . 48%	. 48% . 48% 0% . 48%	. 68% h00% h00% . 58%	A . 48 %
( idcFuedTkiFcSCeLT WLnuaAULsikiFcSC	0 h 0 h	h h h 0 1	h 0 0 0 h	A :
% ( idcFuedTkiFcSCeLT WLnuaAULsikiFcSC	0% h8 % 0% h8 %	h8 % h8 % 0% h8 %	38% 0% 0% 18 %	A h8%
BFGaC	0 0 0 0	0 0 0 0	0 0 0 0	A 0
% BFGaC	0% 0% 0% 0%	0% 0% 0% 0%	0% 0% 0% 0%	A 0%
BscPcuCyLo yeT	0 0 0 0	0 0 0 0	0 0 0 0	A 0
% BscPcuCyLo yeT	0% 0% 0% 0%	0% 0% 0% 0%	0% 0% 0% 0%	A 0%
- aTaGdseLC	A A A A 0	A A A A 0	A A A A 4	
% - aTaGdseLC	A A A A A	A A A A A	A A A A h00%	A
BscPcuCyL) iyCRetS	A A A A 0	A A A A 0	A A A A 0	
% BscPcuCyL) iyCRetS	A A A A A	A A A A A	A A A A 0%	A

\* - aTaGdseLCeLT BscPcuCyL) iyCRetS8l Dl afdo Db sngd2k Dk giF2UDUAk FiL

South Street-Mulberry Street Saturday Midday - TMC

Wed Mar 1, 21013

M Fri a Lndg thh ( 7 A - 7 9

( u) ueCGaCtI sngdC2( idcFuedT kiFcSCeLT WLnuaAULsdkiFcSC2BFGaC2- aTaCIdseLC2BscPcuac  
yLo yeT2BscPcuCyL) iyCCRet69

( u7 ywav aLdC

h Dh0: 144: 2l ycedyLD h8 160h, 2A38 053: h



- iywTaTr PD) iasngdL 7 eLLsLn  
bLnsLaaisLn2l l -  
1 E sLLaiC) sicua2  
( u eLP2NY2h110, 2UW

[N] Mulberry St

Total: 333

In: 91 Out: 66

4 26 3

0 9

[W] South St

Total: 303

In: 61 Out: 66

6

46

45

63

Out: 51 In: 317

Total: 291

[E] South St

South Street-Mulberry Street Saturday Midday - TMC

Sat Feb 25, 2023

Midday Peak (WKND) (11-15 OM v 12-15 PM) vr l eHwPeak u ACH

Oos aLLeL(gihctL, OHITCated n HCikLaUd SiUhevBUit n HCikL, RCleL, PedelitHaUL, RiTyTeLAUwAad, RiTyTeLAUs HALLmack)

OoMAI eI eUL

:D- 1042884, g ATatiAU 417.29015, vE37.0E341



PHN ided by- s HihctAUMaUUh  
YUhiUeeHUh, ggP  
2 WiUeHLs iHTe,  
OObaUy, Np , 12205, BS

geh Dih*TiAU	SACtc St YaIrbACUd	SACtc St WelIrbACUd	MCbceHy St SAGcbACUd	
nil e	g n B O** Ped6	n w B O** Ped6	g w B O** Ped6	:U
2023\02\25 11-15OM	1 E 0 8 0	14 2 0 19 0	1 0 0 1 0	25
11-30OM	0 4 0 4 0	8 9 0 14 0	1 1 0 2 1	20
11-45OM	1 5 0 9 0	11 9 0 1E 0	0 1 0 1 0	24
12-00PM	0 9 0 9 0	3 12 0 15 0	4 2 1 E 1	28
<b>n Aao</b>	2 22 0 24 0	39 29 0 92 0	9 4 1 11 2	. E
<b>% O**HATc</b>	87% .17% 0% v v	587% 417% 0% v v	547% 397% .71% v v	v
<b>% n Aao</b>	27% 22% 0% 24% v	3E7% 297% 0% 937% v	92% 47% 17% 117% v	v
<b>Pu F</b>	07500 07E89 v 07E50 v	07B43 07542 v 07.12 v	07BE5 07500 07250 07.3 v	07B99
<b>gihctL</b>	2 21 0 23 v	35 29 0 91 v	9 4 1 11 v	.5
<b>% gihctL</b>	100% .57% 0% .57% v	.E2% 100% 0% .874% v	100% 100% 100% 100% v	.E7%
<b>OHITCated n HCikLaUd SiUhevBUit n HCikL</b>	0 1 0 1 v	1 0 0 1 v	0 0 0 0 v	2
<b>% OHITCated n HCikLaUd SiUhevBUit n HCikL</b>	0% 47% 0% 42% v	27% 0% 0% 17% v	0% 0% 0% 0% v	27%
<b>RCleL</b>	0 0 0 0 v	0 0 0 0 v	0 0 0 0 v	0
<b>% RCleL</b>	0% 0% 0% 0% v	0% 0% 0% 0% v	0% 0% 0% 0% v	0%
<b>RiTyTeLAUwAad</b>	0 0 0 0 v	0 0 0 0 v	0 0 0 0 v	0
<b>% RiTyTeLAUwAad</b>	0% 0% 0% 0% v	0% 0% 0% 0% v	0% 0% 0% 0% v	0%
<b>PedelitHaUL</b>	v v v v 0	v v v v 0	v v v v 2	
<b>% PedelitHaUL</b>	v v v v v	v v v v v	v v v v v	100% v
<b>RiTyTeLAUs HALLmack</b>	v v v v 0	v v v v 0	v v v v 0	
<b>% RiTyTeLAUs HALLmack</b>	v v v v v	v v v v v	v v v v v	0% v

<sup>6</sup>PedelitHaULaUd RiTyTeLAUs HALLmack7g- geft, w- wihct, n- n cHC, B- Bvn CHU

South Street-Mulberry Street Saturday Midday - TMC

Sat Feb 25, 2023

Midday Peak (WKND) (11:15 AM - 12:15 PM) - Overall Peak Hour

All Classes (Lights, Articulated Trucks and Single-Unit Trucks, Buses, Pedestrians, Bicycles on Road, Bicycles on Crosswalk)

All Movements

ID: 1042884, Location: 41.926015, -73.907341



Provided by: Creighton Manning Engineering, LLP  
2 Winners Circle,  
Albany, NY, 12205, US

[N] Mulberry St

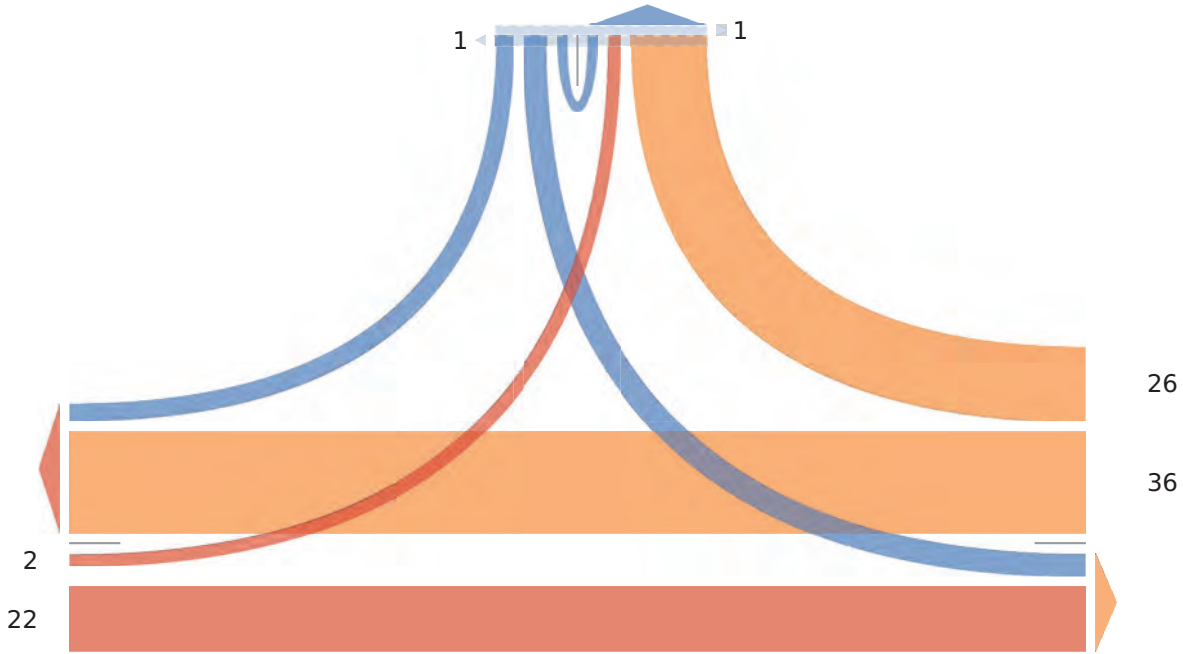
Total: 40

In: 11 Out: 29

4 6 1

1 1

[W] South St  
Total: 64  
In: 24 Out: 40



South Street-Mulberry Street Saturday Midday - TMC

Sat Feb 25, 2023

PM Peak (WKND) (1 PM - 2 PM)

All Classes (Lights, Articulated Trucks and Single-Unit Trucks, Buses, Pedestrians, Bicycles on Road, Bicycles on Crosswalk)

All Movements

ID: 1042884, Location: 41.926015, -73.907341



Provided by: Creighton Manning Engineering, LLP  
2 Winners Circle,  
Albany, NY, 12205, US

Leg Direction	South St Eastbound					South St Westbound					Mulberry St Southbound					
Time	L	T	U	App	Ped*	T	R	U	App	Ped*	L	R	U	App	Ped*	Int
2023-02-25 1:00PM	0	0	0	0	0	7	4	0	11	0	2	0	0	2	0	13
1:15PM	0	4	0	4	0	3	4	0	7	0	3	1	0	4	5	15
1:30PM	1	9	0	10	0	4	11	0	15	0	6	0	0	6	0	31
1:45PM	1	6	0	7	0	8	10	0	18	0	4	0	0	4	0	29
<b>Total</b>	<b>2</b>	<b>19</b>	<b>0</b>	<b>21</b>	<b>0</b>	<b>22</b>	<b>29</b>	<b>0</b>	<b>51</b>	<b>0</b>	<b>15</b>	<b>1</b>	<b>0</b>	<b>16</b>	<b>5</b>	<b>88</b>
<b>% Approach</b>	9.5%	90.5%	0%	-	-	43.1%	56.9%	0%	-	-	93.8%	6.3%	0%	-	-	-
<b>% Total</b>	2.3%	21.6%	0%	<b>23.9%</b>	-	25.0%	33.0%	0%	<b>58.0%</b>	-	17.0%	1.1%	0%	<b>18.2%</b>	-	-
<b>PHF</b>	0.500	0.528	-	<b>0.525</b>	-	0.688	0.659	-	<b>0.708</b>	-	0.625	0.250	-	<b>0.667</b>	-	0.710
<b>Lights</b>	2	19	0	<b>21</b>	-	22	28	0	<b>50</b>	-	14	1	0	<b>15</b>	-	86
<b>% Lights</b>	100%	100%	0%	<b>100%</b>	-	100%	96.6%	0%	<b>98.0%</b>	-	93.3%	100%	0%	<b>93.8%</b>	-	97.7%
<b>Articulated Trucks and Single-Unit Trucks</b>	0	0	0	<b>0</b>	-	0	1	0	<b>1</b>	-	1	0	0	<b>1</b>	-	2
<b>% Articulated Trucks and Single-Unit Trucks</b>	0%	0%	0%	<b>0%</b>	-	0%	3.4%	0%	<b>2.0%</b>	-	6.7%	0%	0%	<b>6.3%</b>	-	2.3%
<b>Buses</b>	0	0	0	<b>0</b>	-	0	0	0	<b>0</b>	-	0	0	0	<b>0</b>	-	0
<b>% Buses</b>	0%	0%	0%	<b>0%</b>	-	0%	0%	0%	<b>0%</b>	-	0%	0%	0%	<b>0%</b>	-	0%
<b>Bicycles on Road</b>	0	0	0	<b>0</b>	-	0	0	0	<b>0</b>	-	0	0	0	<b>0</b>	-	0
<b>% Bicycles on Road</b>	0%	0%	0%	<b>0%</b>	-	0%	0%	0%	<b>0%</b>	-	0%	0%	0%	<b>0%</b>	-	0%
Pedestrians	-	-	-	-	0	-	-	-	-	0	-	-	-	-	5	-
<b>% Pedestrians</b>	-	-	-	-	-	-	-	-	-	-	-	-	-	-	100%	-
Bicycles on Crosswalk	-	-	-	-	0	-	-	-	-	0	-	-	-	-	0	-
<b>% Bicycles on Crosswalk</b>	-	-	-	-	-	-	-	-	-	-	-	-	-	-	0%	-

\* Pedestrians and Bicycles on Crosswalk. L: Left, R: Right, T: Thru, U: U-Turn

South Street-Mulberry Street Saturday Midday - TMC

Sat Feb 25, 2023

PM Peak (WKND) (1 PM - 2 PM)

All Classes (Lights, Articulated Trucks and Single-Unit Trucks, Buses, Pedestrians, Bicycles on Road, Bicycles on Crosswalk)

All Movements

ID: 1042884, Location: 41.926015, -73.907341



Provided by: Creighton Manning Engineering, LLP  
2 Winners Circle,  
Albany, NY, 12205, US

[N] Mulberry St

Total: 14

In: 97 Out: 89

9 3

1

9

[W] South St

Total: 11

In: 59 Out: 58

5

96

56

55

Out: 81 In: 39

Total: 23

[E] South St



**ATTACHMENT C  
LEVEL OF SERVICE ANALYSIS**

6 Mulberry Street  
Village of Rhinebeck  
Dutchess County, New York

Intersection												
Int Delay, s/veh	4.1											
Movement	EBL	EBT	EBR	WBL	WBT	WBR	NBL	NBT	NBR	SBL	SBT	SBR
Lane Configurations		↕			↕			↕			↕	
Traffic Vol, veh/h	6	98	2	5	121	34	19	48	3	33	5	9
Future Vol, veh/h	6	98	2	5	121	34	19	48	3	33	5	9
Conflicting Peds, #/hr	3	0	6	6	0	3	2	0	2	2	0	2
Sign Control	Free	Free	Free	Free	Free	Free	Stop	Stop	Stop	Stop	Stop	Stop
RT Channelized	-	-	None	-	-	None	-	-	None	-	-	None
Storage Length	-	-	-	-	-	-	-	-	-	-	-	-
Veh in Median Storage, #	-	0	-	-	0	-	-	0	-	-	0	-
Grade, %	-	0	-	-	0	-	-	0	-	-	0	-
Peak Hour Factor	74	74	74	74	74	74	74	74	74	74	74	74
Heavy Vehicles, %	0	3	0	0	3	0	6	10	0	3	0	0
Mvmt Flow	8	132	3	7	164	46	26	65	4	45	7	12

Major/Minor	Major1			Major2			Minor1			Minor2		
Conflicting Flow All	213	0	0	141	0	0	369	383	142	390	361	192
Stage 1	-	-	-	-	-	-	156	156	-	204	204	-
Stage 2	-	-	-	-	-	-	213	227	-	186	157	-
Critical Hdwy	4.1	-	-	4.1	-	-	7.16	6.6	6.2	7.13	6.5	6.2
Critical Hdwy Stg 1	-	-	-	-	-	-	6.16	5.6	-	6.13	5.5	-
Critical Hdwy Stg 2	-	-	-	-	-	-	6.16	5.6	-	6.13	5.5	-
Follow-up Hdwy	2.2	-	-	2.2	-	-	3.554	4.09	3.3	3.527	4	3.3
Pot Cap-1 Maneuver	1369	-	-	1455	-	-	580	538	911	567	569	855
Stage 1	-	-	-	-	-	-	837	754	-	796	737	-
Stage 2	-	-	-	-	-	-	780	701	-	813	772	-
Platoon blocked, %	-	-	-	-	-	-	-	-	-	-	-	-
Mov Cap-1 Maneuver	1365	-	-	1447	-	-	557	527	904	504	557	851
Mov Cap-2 Maneuver	-	-	-	-	-	-	557	527	-	504	557	-
Stage 1	-	-	-	-	-	-	827	745	-	789	730	-
Stage 2	-	-	-	-	-	-	756	695	-	733	763	-

Approach	EB			WB			NB			SB		
HCM Control Delay, s	0.4			0.2			13			12.4		
HCM LOS							B			B		

Minor Lane/Major Mvmt	NBLn1	EBL	EBT	EBR	WBL	WBT	WBR	SBLn1
Capacity (veh/h)	545	1365	-	-	1447	-	-	553
HCM Lane V/C Ratio	0.174	0.006	-	-	0.005	-	-	0.115
HCM Control Delay (s)	13	7.7	0	-	7.5	0	-	12.4
HCM Lane LOS	B	A	A	-	A	A	-	B
HCM 95th %tile Q(veh)	0.6	0	-	-	0	-	-	0.4

Intersection												
Int Delay, s/veh	2.7											
Movement	EBL	EBT	EBR	WBL	WBT	WBR	NBL	NBT	NBR	SBL	SBT	SBR
Lane Configurations		↕			↕						↕	
Traffic Vol, veh/h	4	70	60	94	159	8	0	0	0	4	25	1
Future Vol, veh/h	4	70	60	94	159	8	0	0	0	4	25	1
Conflicting Peds, #/hr	0	0	2	2	0	0	0	0	0	0	0	0
Sign Control	Free	Free	Free	Free	Free	Free	Stop	Stop	Stop	Stop	Stop	Stop
RT Channelized	-	-	None	-	-	None	-	-	None	-	-	None
Storage Length	-	-	-	-	-	-	-	-	-	-	-	-
Veh in Median Storage, #	-	0	-	-	0	-	-	0	-	-	0	-
Grade, %	-	0	-	-	0	-	-	0	-	-	0	-
Peak Hour Factor	76	76	76	76	76	76	76	76	76	76	76	76
Heavy Vehicles, %	0	4	3	5	0	0	2	2	2	0	4	0
Mvmt Flow	5	92	79	124	209	11	0	0	0	5	33	1

Major/Minor	Major1			Major2			Minor2		
Conflicting Flow All	220	0	0	173	0	0	605	646	215
Stage 1	-	-	-	-	-	-	463	463	-
Stage 2	-	-	-	-	-	-	142	183	-
Critical Hdwy	4.1	-	-	4.15	-	-	6.4	6.54	6.2
Critical Hdwy Stg 1	-	-	-	-	-	-	5.4	5.54	-
Critical Hdwy Stg 2	-	-	-	-	-	-	5.4	5.54	-
Follow-up Hdwy	2.2	-	-	2.245	-	-	3.5	4.036	3.3
Pot Cap-1 Maneuver	1361	-	-	1386	-	-	464	388	830
Stage 1	-	-	-	-	-	-	638	561	-
Stage 2	-	-	-	-	-	-	890	744	-
Platoon blocked, %	-	-	-	-	-	-	-	-	-
Mov Cap-1 Maneuver	1361	-	-	1386	-	-	415	0	830
Mov Cap-2 Maneuver	-	-	-	-	-	-	415	0	-
Stage 1	-	-	-	-	-	-	635	0	-
Stage 2	-	-	-	-	-	-	799	0	-

Approach	EB	WB	SB
HCM Control Delay, s	0.2	2.8	13.5
HCM LOS			B

Minor Lane/Major Mvmt	EBL	EBT	EBR	WBL	WBT	WBR	SBLn1
Capacity (veh/h)	1361	-	-	1386	-	-	461
HCM Lane V/C Ratio	0.004	-	-	0.089	-	-	0.086
HCM Control Delay (s)	7.7	0	-	7.9	0	-	13.5
HCM Lane LOS	A	A	-	A	A	-	B
HCM 95th %tile Q(veh)	0	-	-	0.3	-	-	0.3

Intersection						
Int Delay, s/veh	1					
Movement	EBL	EBT	WBT	WBR	SBL	SBR
Lane Configurations		↕	↕		↕	
Traffic Vol, veh/h	5	22	49	65	10	2
Future Vol, veh/h	5	22	49	65	10	2
Conflicting Peds, #/hr	1	0	0	1	1	0
Sign Control	Free	Free	Free	Free	Stop	Stop
RT Channelized	-	None	-	None	-	None
Storage Length	-	-	-	-	0	-
Veh in Median Storage, #	-	0	0	-	0	-
Grade, %	-	0	0	-	0	-
Peak Hour Factor	58	58	58	58	58	58
Heavy Vehicles, %	0	4	2	8	0	0
Mvmt Flow	9	38	84	112	17	3

Major/Minor	Major1	Major2	Minor2		
Conflicting Flow All	197	0	-	0	198 141
Stage 1	-	-	-	-	141 -
Stage 2	-	-	-	-	57 -
Critical Hdwy	4.1	-	-	-	6.4 6.2
Critical Hdwy Stg 1	-	-	-	-	5.4 -
Critical Hdwy Stg 2	-	-	-	-	5.4 -
Follow-up Hdwy	2.2	-	-	-	3.5 3.3
Pot Cap-1 Maneuver	1388	-	-	-	795 912
Stage 1	-	-	-	-	891 -
Stage 2	-	-	-	-	971 -
Platoon blocked, %		-	-	-	
Mov Cap-1 Maneuver	1387	-	-	-	788 911
Mov Cap-2 Maneuver	-	-	-	-	788 -
Stage 1	-	-	-	-	884 -
Stage 2	-	-	-	-	970 -

Approach	EB	WB	SB
HCM Control Delay, s	1.4	0	9.6
HCM LOS			A

Minor Lane/Major Mvmt	EBL	EBT	WBT	WBR	SBLn1
Capacity (veh/h)	1387	-	-	-	806
HCM Lane V/C Ratio	0.006	-	-	-	0.026
HCM Control Delay (s)	7.6	0	-	-	9.6
HCM Lane LOS	A	A	-	-	A
HCM 95th %tile Q(veh)	0	-	-	-	0.1

Intersection												
Int Delay, s/veh	5.1											
Movement	EBL	EBT	EBR	WBL	WBT	WBR	NBL	NBT	NBR	SBL	SBT	SBR
Lane Configurations		↔			↔			↔			↔	
Traffic Vol, veh/h	0	8	20	29	18	0	95	85	0	0	178	1
Future Vol, veh/h	0	8	20	29	18	0	95	85	0	0	178	1
Conflicting Peds, #/hr	0	0	0	0	0	0	0	0	0	0	0	0
Sign Control	Stop	Stop	Stop	Stop	Stop	Stop	Free	Free	Free	Free	Free	Free
RT Channelized	-	-	None	-	-	None	-	-	None	-	-	None
Storage Length	-	-	-	-	-	-	-	-	-	-	-	-
Veh in Median Storage, #	-	0	-	-	0	-	-	0	-	-	0	-
Grade, %	-	0	-	-	0	-	-	0	-	-	0	-
Peak Hour Factor	61	61	61	61	61	61	61	61	61	61	61	61
Heavy Vehicles, %	0	0	0	0	6	0	4	0	8	0	3	100
Mvmt Flow	0	13	33	48	30	0	156	139	0	0	292	2

Major/Minor	Minor2		Minor1		Major1		Major2					
Conflicting Flow All	-	744	293	767	745	-	294	0	0	139	0	0
Stage 1	-	293	-	451	451	-	-	-	-	-	-	-
Stage 2	-	451	-	316	294	-	-	-	-	-	-	-
Critical Hdwy	-	6.5	6.2	7.1	6.56	-	4.14	-	-	4.1	-	-
Critical Hdwy Stg 1	-	5.5	-	6.1	5.56	-	-	-	-	-	-	-
Critical Hdwy Stg 2	-	5.5	-	6.1	5.56	-	-	-	-	-	-	-
Follow-up Hdwy	-	4	3.3	3.5	4.054	-	2.236	-	-	2.2	-	-
Pot Cap-1 Maneuver	0	345	751	322	338	0	1256	-	-	1457	-	-
Stage 1	0	674	-	592	564	0	-	-	-	-	-	-
Stage 2	0	574	-	699	662	0	-	-	-	-	-	-
Platoon blocked, %								-	-	-	-	-
Mov Cap-1 Maneuver	-	298	751	267	292	-	1256	-	-	1457	-	-
Mov Cap-2 Maneuver	-	298	-	267	292	-	-	-	-	-	-	-
Stage 1	-	674	-	512	488	-	-	-	-	-	-	-
Stage 2	-	497	-	655	662	-	-	-	-	-	-	-

Approach	EB		WB		NB		SB	
HCM Control Delay, s	12.5		23		4.4		0	
HCM LOS	B		C					

Minor Lane/Major Mvmt	NBL	NBT	NBR	EBLn1WBLn1	SBL	SBT	SBR
Capacity (veh/h)	1256	-	-	524	276	1457	-
HCM Lane V/C Ratio	0.124	-	-	0.088	0.279	-	-
HCM Control Delay (s)	8.3	0	-	12.5	23	0	-
HCM Lane LOS	A	A	-	B	C	A	-
HCM 95th %tile Q(veh)	0.4	-	-	0.3	1.1	0	-

Intersection												
Int Delay, s/veh	5.1											
Movement	EBL	EBT	EBR	WBL	WBT	WBR	NBL	NBT	NBR	SBL	SBT	SBR
Lane Configurations		↕			↕			↕			↕	
Traffic Vol, veh/h	21	170	4	2	116	30	22	75	6	35	18	14
Future Vol, veh/h	21	170	4	2	116	30	22	75	6	35	18	14
Conflicting Peds, #/hr	4	0	27	27	0	4	3	0	0	0	0	3
Sign Control	Free	Free	Free	Free	Free	Free	Stop	Stop	Stop	Stop	Stop	Stop
RT Channelized	-	-	None	-	-	None	-	-	None	-	-	None
Storage Length	-	-	-	-	-	-	-	-	-	-	-	-
Veh in Median Storage, #	-	0	-	-	0	-	-	0	-	-	0	-
Grade, %	-	0	-	-	0	-	-	0	-	-	0	-
Peak Hour Factor	85	85	85	85	85	85	85	85	85	85	85	85
Heavy Vehicles, %	0	2	0	0	2	2	3	5	0	1	7	0
Mvmt Flow	25	200	5	2	136	35	26	88	7	41	21	16

Major/Minor	Major1			Major2			Minor1			Minor2		
Conflicting Flow All	175	0	0	232	0	0	459	459	230	462	444	161
Stage 1	-	-	-	-	-	-	280	280	-	162	162	-
Stage 2	-	-	-	-	-	-	179	179	-	300	282	-
Critical Hdwy	4.1	-	-	4.1	-	-	7.13	6.55	6.2	7.11	6.57	6.2
Critical Hdwy Stg 1	-	-	-	-	-	-	6.13	5.55	-	6.11	5.57	-
Critical Hdwy Stg 2	-	-	-	-	-	-	6.13	5.55	-	6.11	5.57	-
Follow-up Hdwy	2.2	-	-	2.2	-	-	3.527	4.045	3.3	3.509	4.063	3.3
Pot Cap-1 Maneuver	1414	-	-	1348	-	-	511	494	814	512	501	889
Stage 1	-	-	-	-	-	-	725	674	-	842	755	-
Stage 2	-	-	-	-	-	-	820	746	-	711	669	-
Platoon blocked, %	-	-	-	-	-	-	-	-	-	-	-	-
Mov Cap-1 Maneuver	1409	-	-	1313	-	-	463	469	793	425	475	883
Mov Cap-2 Maneuver	-	-	-	-	-	-	463	469	-	425	475	-
Stage 1	-	-	-	-	-	-	692	644	-	822	750	-
Stage 2	-	-	-	-	-	-	778	742	-	596	639	-

Approach	EB			WB			NB			SB		
HCM Control Delay, s	0.8			0.1			15			13.7		
HCM LOS							C			B		

Minor Lane/Major Mvmt	NBLn1	EBL	EBT	EBR	WBL	WBT	WBR	SBLn1
Capacity (veh/h)	479	1409	-	-	1313	-	-	492
HCM Lane V/C Ratio	0.253	0.018	-	-	0.002	-	-	0.16
HCM Control Delay (s)	15	7.6	0	-	7.7	0	-	13.7
HCM Lane LOS	C	A	A	-	A	A	-	B
HCM 95th %tile Q(veh)	1	0.1	-	-	0	-	-	0.6

Intersection												
Int Delay, s/veh	1.5											
Movement	EBL	EBT	EBR	WBL	WBT	WBR	NBL	NBT	NBR	SBL	SBT	SBR
Lane Configurations		↕			↕						↕	
Traffic Vol, veh/h	2	160	49	28	147	9	0	0	0	8	27	1
Future Vol, veh/h	2	160	49	28	147	9	0	0	0	8	27	1
Conflicting Peds, #/hr	10	0	3	3	0	10	0	0	0	7	0	0
Sign Control	Free	Free	Free	Free	Free	Free	Stop	Stop	Stop	Stop	Stop	Stop
RT Channelized	-	-	None	-	-	None	-	-	None	-	-	None
Storage Length	-	-	-	-	-	-	-	-	-	-	-	-
Veh in Median Storage, #	-	0	-	-	0	-	-	0	-	-	0	-
Grade, %	-	0	-	-	0	-	-	0	-	-	0	-
Peak Hour Factor	98	98	98	98	98	98	98	98	98	98	98	98
Heavy Vehicles, %	0	2	4	11	2	0	0	0	0	6	0	0
Mvmt Flow	2	163	50	29	150	9	0	0	0	8	28	1

Major/Minor	Major1			Major2			Minor2		
Conflicting Flow All	169	0	0	216	0	0	422	443	165
Stage 1	-	-	-	-	-	-	223	223	-
Stage 2	-	-	-	-	-	-	199	220	-
Critical Hdwy	4.1	-	-	4.21	-	-	6.46	6.5	6.2
Critical Hdwy Stg 1	-	-	-	-	-	-	5.46	5.5	-
Critical Hdwy Stg 2	-	-	-	-	-	-	5.46	5.5	-
Follow-up Hdwy	2.2	-	-	2.299	-	-	3.554	4	3.3
Pot Cap-1 Maneuver	1421	-	-	1302	-	-	581	512	885
Stage 1	-	-	-	-	-	-	805	723	-
Stage 2	-	-	-	-	-	-	825	725	-
Platoon blocked, %	-	-	-	-	-	-	-	-	-
Mov Cap-1 Maneuver	1407	-	-	1302	-	-	555	0	877
Mov Cap-2 Maneuver	-	-	-	-	-	-	555	0	-
Stage 1	-	-	-	-	-	-	795	0	-
Stage 2	-	-	-	-	-	-	798	0	-

Approach	EB		WB		SB	
HCM Control Delay, s	0.1		1.2		11.6	
HCM LOS					B	

Minor Lane/Major Mvmt	EBL	EBT	EBR	WBL	WBT	WBR	SBLn1
Capacity (veh/h)	1407	-	-	1302	-	-	579
HCM Lane V/C Ratio	0.001	-	-	0.022	-	-	0.063
HCM Control Delay (s)	7.6	0	-	7.8	0	-	11.6
HCM Lane LOS	A	A	-	A	A	-	B
HCM 95th %tile Q(veh)	0	-	-	0.1	-	-	0.2

**Intersection**

Int Delay, s/veh 1.2

Movement	EBL	EBT	WBT	WBR	SBL	SBR
Lane Configurations		↕	↕		↕	
Traffic Vol, veh/h	5	48	55	98	22	2
Future Vol, veh/h	5	48	55	98	22	2
Conflicting Peds, #/hr	9	0	0	9	0	0
Sign Control	Free	Free	Free	Free	Stop	Stop
RT Channelized	-	None	-	None	-	None
Storage Length	-	-	-	-	0	-
Veh in Median Storage, #	-	0	0	-	0	-
Grade, %	-	0	0	-	0	-
Peak Hour Factor	72	72	72	72	72	72
Heavy Vehicles, %	13	5	0	4	6	0
Mvmt Flow	7	67	76	136	31	3

Major/Minor	Major1	Major2	Minor2		
Conflicting Flow All	221	0	-	0	234
Stage 1	-	-	-	-	153
Stage 2	-	-	-	-	81
Critical Hdwy	4.23	-	-	-	6.46
Critical Hdwy Stg 1	-	-	-	-	5.46
Critical Hdwy Stg 2	-	-	-	-	5.46
Follow-up Hdwy	2.317	-	-	-	3.554
Pot Cap-1 Maneuver	1286	-	-	-	745
Stage 1	-	-	-	-	865
Stage 2	-	-	-	-	932
Platoon blocked, %		-	-	-	
Mov Cap-1 Maneuver	1275	-	-	-	727
Mov Cap-2 Maneuver	-	-	-	-	727
Stage 1	-	-	-	-	852
Stage 2	-	-	-	-	924

Approach	EB	WB	SB
HCM Control Delay, s	0.7	0	10.1
HCM LOS			B

Minor Lane/Major Mvmt	EBL	EBT	WBT	WBR	SBLn1
Capacity (veh/h)	1275	-	-	-	738
HCM Lane V/C Ratio	0.005	-	-	-	0.045
HCM Control Delay (s)	7.8	0	-	-	10.1
HCM Lane LOS	A	A	-	-	B
HCM 95th %tile Q(veh)	0	-	-	-	0.1



Intersection												
Int Delay, s/veh	5.3											
Movement	EBL	EBT	EBR	WBL	WBT	WBR	NBL	NBT	NBR	SBL	SBT	SBR
Lane Configurations		↻			↻			↻			↻	
Traffic Vol, veh/h	0	20	50	31	13	0	135	0	132	2	97	5
Future Vol, veh/h	0	20	50	31	13	0	135	0	132	2	97	5
Conflicting Peds, #/hr	0	0	0	0	0	0	0	0	0	0	0	0
Sign Control	Stop	Stop	Stop	Stop	Stop	Stop	Free	Free	Free	Free	Free	Free
RT Channelized	-	-	None	-	-	None	-	-	None	-	-	None
Storage Length	-	-	-	-	-	-	-	-	-	-	-	-
Veh in Median Storage, #	-	0	-	-	0	-	-	0	-	-	0	-
Grade, %	-	0	-	-	0	-	-	0	-	-	0	-
Peak Hour Factor	84	84	84	84	84	84	84	84	84	84	84	84
Heavy Vehicles, %	0	10	6	3	0	0	2	0	5	0	5	0
Mvmt Flow	0	24	60	37	15	0	161	0	157	2	115	6

Major/Minor	Minor2		Minor1			Major1			Major2			
Conflicting Flow All	-	601	118	565	526	-	121	0	0	157	0	0
Stage 1	-	122	-	401	401	-	-	-	-	-	-	-
Stage 2	-	479	-	164	125	-	-	-	-	-	-	-
Critical Hdwy	-	6.6	6.26	7.13	6.5	-	4.12	-	-	4.1	-	-
Critical Hdwy Stg 1	-	5.6	-	6.13	5.5	-	-	-	-	-	-	-
Critical Hdwy Stg 2	-	5.6	-	6.13	5.5	-	-	-	-	-	-	-
Follow-up Hdwy	-	4.09	3.354	3.527	4	-	2.218	-	-	2.2	-	-
Pot Cap-1 Maneuver	0	404	923	434	460	0	1467	-	-	1435	-	-
Stage 1	0	780	-	624	604	0	-	-	-	-	-	-
Stage 2	0	542	-	836	796	0	-	-	-	-	-	-
Platoon blocked, %								-	-	-	-	-
Mov Cap-1 Maneuver	-	354	923	349	403	-	1467	-	-	1435	-	-
Mov Cap-2 Maneuver	-	354	-	349	403	-	-	-	-	-	-	-
Stage 1	-	779	-	547	530	-	-	-	-	-	-	-
Stage 2	-	475	-	757	795	-	-	-	-	-	-	-

Approach	EB		WB		NB		SB	
HCM Control Delay, s	11.5		16.6		3.9		0.1	
HCM LOS	B		C					

Minor Lane/Major Mvmt	NBL	NBT	NBR	EBLn1WBLn1	SBL	SBT	SBR
Capacity (veh/h)	1467	-	-	633	363	1435	-
HCM Lane V/C Ratio	0.11	-	-	0.132	0.144	0.002	-
HCM Control Delay (s)	7.8	0	-	11.5	16.6	7.5	0
HCM Lane LOS	A	A	-	B	C	A	A
HCM 95th %tile Q(veh)	0.4	-	-	0.5	0.5	0	-

Intersection												
Int Delay, s/veh	3.1											
Movement	EBL	EBT	EBR	WBL	WBT	WBR	NBL	NBT	NBR	SBL	SBT	SBR
Lane Configurations		↕			↕			↕			↕	
Traffic Vol, veh/h	19	181	4	5	146	20	25	24	6	30	7	13
Future Vol, veh/h	19	181	4	5	146	20	25	24	6	30	7	13
Conflicting Peds, #/hr	2	0	4	4	0	2	2	0	1	1	0	2
Sign Control	Free	Free	Free	Free	Free	Free	Stop	Stop	Stop	Stop	Stop	Stop
RT Channelized	-	-	None	-	-	None	-	-	None	-	-	None
Storage Length	-	-	-	-	-	-	-	-	-	-	-	-
Veh in Median Storage, #	-	0	-	-	0	-	-	0	-	-	0	-
Grade, %	-	0	-	-	0	-	-	0	-	-	0	-
Peak Hour Factor	90	90	90	90	90	90	90	90	90	90	90	90
Heavy Vehicles, %	6	2	0	0	4	0	4	0	0	0	0	8
Mvmt Flow	21	201	4	6	162	22	28	27	7	33	8	14

Major/Minor	Major1			Major2			Minor1			Minor2		
Conflicting Flow All	186	0	0	209	0	0	447	447	208	450	438	177
Stage 1	-	-	-	-	-	-	249	249	-	187	187	-
Stage 2	-	-	-	-	-	-	198	198	-	263	251	-
Critical Hdwy	4.16	-	-	4.1	-	-	7.14	6.5	6.2	7.1	6.5	6.28
Critical Hdwy Stg 1	-	-	-	-	-	-	6.14	5.5	-	6.1	5.5	-
Critical Hdwy Stg 2	-	-	-	-	-	-	6.14	5.5	-	6.1	5.5	-
Follow-up Hdwy	2.254	-	-	2.2	-	-	3.536	4	3.3	3.5	4	3.372
Pot Cap-1 Maneuver	1365	-	-	1374	-	-	518	509	837	523	515	851
Stage 1	-	-	-	-	-	-	751	704	-	819	749	-
Stage 2	-	-	-	-	-	-	799	741	-	747	703	-
Platoon blocked, %	-	-	-	-	-	-	-	-	-	-	-	-
Mov Cap-1 Maneuver	1362	-	-	1369	-	-	492	495	833	488	501	848
Mov Cap-2 Maneuver	-	-	-	-	-	-	492	495	-	488	501	-
Stage 1	-	-	-	-	-	-	735	689	-	803	744	-
Stage 2	-	-	-	-	-	-	772	736	-	700	688	-

Approach	EB			WB			NB			SB		
HCM Control Delay, s	0.7			0.2			12.9			12.3		
HCM LOS							B			B		

Minor Lane/Major Mvmt	NBLn1	EBL	EBT	EBR	WBL	WBT	WBR	SBLn1
Capacity (veh/h)	516	1362	-	-	1369	-	-	551
HCM Lane V/C Ratio	0.118	0.016	-	-	0.004	-	-	0.101
HCM Control Delay (s)	12.9	7.7	0	-	7.6	0	-	12.3
HCM Lane LOS	B	A	A	-	A	A	-	B
HCM 95th %tile Q(veh)	0.4	0	-	-	0	-	-	0.3

Intersection						
Int Delay, s/veh	1.4					
Movement	EBL	EBT	WBT	WBR	SBL	SBR
Lane Configurations		↕	↕		↕	
Traffic Vol, veh/h	6	36	30	49	13	3
Future Vol, veh/h	6	36	30	49	13	3
Conflicting Peds, #/hr	4	0	0	0	0	0
Sign Control	Free	Free	Free	Free	Stop	Stop
RT Channelized	-	None	-	None	-	None
Storage Length	-	-	-	-	0	-
Veh in Median Storage, #	-	0	0	-	0	-
Grade, %	-	0	0	-	0	-
Peak Hour Factor	89	89	89	89	89	89
Heavy Vehicles, %	0	2	4	1	0	0
Mvmt Flow	7	40	34	55	15	3

Major/Minor	Major1	Major2	Minor2		
Conflicting Flow All	93	0	-	0	120 66
Stage 1	-	-	-	-	66 -
Stage 2	-	-	-	-	54 -
Critical Hdwy	4.1	-	-	-	6.4 6.2
Critical Hdwy Stg 1	-	-	-	-	5.4 -
Critical Hdwy Stg 2	-	-	-	-	5.4 -
Follow-up Hdwy	2.2	-	-	-	3.5 3.3
Pot Cap-1 Maneuver	1514	-	-	-	880 1003
Stage 1	-	-	-	-	962 -
Stage 2	-	-	-	-	974 -
Platoon blocked, %		-	-	-	
Mov Cap-1 Maneuver	1508	-	-	-	869 999
Mov Cap-2 Maneuver	-	-	-	-	869 -
Stage 1	-	-	-	-	953 -
Stage 2	-	-	-	-	970 -

Approach	EB	WB	SB
HCM Control Delay, s	1.1	0	9.1
HCM LOS			A

Minor Lane/Major Mvmt	EBL	EBT	WBT	WBR	SBLn1
Capacity (veh/h)	1508	-	-	-	891
HCM Lane V/C Ratio	0.004	-	-	-	0.02
HCM Control Delay (s)	7.4	0	-	-	9.1
HCM Lane LOS	A	A	-	-	A
HCM 95th %tile Q(veh)	0	-	-	-	0.1

Intersection												
Int Delay, s/veh	2.6											
Movement	EBL	EBT	EBR	WBL	WBT	WBR	NBL	NBT	NBR	SBL	SBT	SBR
Lane Configurations		↕			↕			↕			↕	
Traffic Vol, veh/h	8	145	4	3	150	12	11	19	1	23	12	16
Future Vol, veh/h	8	145	4	3	150	12	11	19	1	23	12	16
Conflicting Peds, #/hr	4	0	27	27	0	4	3	0	0	0	0	3
Sign Control	Free	Free	Free	Free	Free	Free	Stop	Stop	Stop	Stop	Stop	Stop
RT Channelized	-	-	None	-	-	None	-	-	None	-	-	None
Storage Length	-	-	-	-	-	-	-	-	-	-	-	-
Veh in Median Storage, #	-	0	-	-	0	-	-	0	-	-	0	-
Grade, %	-	0	-	-	0	-	-	0	-	-	0	-
Peak Hour Factor	92	92	92	92	92	92	92	92	92	92	92	92
Heavy Vehicles, %	0	3	50	0	4	0	0	0	0	0	0	0
Mvmt Flow	9	158	4	3	163	13	12	21	1	25	13	17

Major/Minor	Major1			Major2			Minor1			Minor2		
Conflicting Flow All	180	0	0	189	0	0	399	391	187	369	387	177
Stage 1	-	-	-	-	-	-	205	205	-	180	180	-
Stage 2	-	-	-	-	-	-	194	186	-	189	207	-
Critical Hdwy	4.1	-	-	4.1	-	-	7.1	6.5	6.2	7.1	6.5	6.2
Critical Hdwy Stg 1	-	-	-	-	-	-	6.1	5.5	-	6.1	5.5	-
Critical Hdwy Stg 2	-	-	-	-	-	-	6.1	5.5	-	6.1	5.5	-
Follow-up Hdwy	2.2	-	-	2.2	-	-	3.5	4	3.3	3.5	4	3.3
Pot Cap-1 Maneuver	1408	-	-	1397	-	-	565	548	860	591	551	871
Stage 1	-	-	-	-	-	-	802	736	-	826	754	-
Stage 2	-	-	-	-	-	-	812	750	-	817	734	-
Platoon blocked, %	-	-	-	-	-	-	-	-	-	-	-	-
Mov Cap-1 Maneuver	1403	-	-	1361	-	-	524	527	838	567	530	865
Mov Cap-2 Maneuver	-	-	-	-	-	-	524	527	-	567	530	-
Stage 1	-	-	-	-	-	-	776	712	-	817	749	-
Stage 2	-	-	-	-	-	-	778	746	-	787	710	-

Approach	EB			WB			NB			SB		
HCM Control Delay, s	0.4			0.1			12.2			11.3		
HCM LOS							B			B		

Minor Lane/Major Mvmt	NBLn1	EBL	EBT	EBR	WBL	WBT	WBR	SBLn1
Capacity (veh/h)	532	1403	-	-	1361	-	-	624
HCM Lane V/C Ratio	0.063	0.006	-	-	0.002	-	-	0.089
HCM Control Delay (s)	12.2	7.6	0	-	7.7	0	-	11.3
HCM Lane LOS	B	A	A	-	A	A	-	B
HCM 95th %tile Q(veh)	0.2	0	-	-	0	-	-	0.3

Intersection						
Int Delay, s/veh	2					
Movement	EBL	EBT	WBT	WBR	SBL	SBR
Lane Configurations		↕	↕		↕	
Traffic Vol, veh/h	2	20	23	30	18	1
Future Vol, veh/h	2	20	23	30	18	1
Conflicting Peds, #/hr	5	0	0	0	0	0
Sign Control	Free	Free	Free	Free	Stop	Stop
RT Channelized	-	None	-	None	-	None
Storage Length	-	-	-	-	0	-
Veh in Median Storage, #	-	0	0	-	0	-
Grade, %	-	0	0	-	0	-
Peak Hour Factor	71	71	71	71	71	71
Heavy Vehicles, %	0	2	1	1	4	0
Mvmt Flow	3	28	32	42	25	1

Major/Minor	Major1	Major2	Minor2		
Conflicting Flow All	79	0	-	0	92 58
Stage 1	-	-	-	-	58 -
Stage 2	-	-	-	-	34 -
Critical Hdwy	4.1	-	-	-	6.44 6.2
Critical Hdwy Stg 1	-	-	-	-	5.44 -
Critical Hdwy Stg 2	-	-	-	-	5.44 -
Follow-up Hdwy	2.2	-	-	-	3.536 3.3
Pot Cap-1 Maneuver	1532	-	-	-	903 1014
Stage 1	-	-	-	-	959 -
Stage 2	-	-	-	-	983 -
Platoon blocked, %		-	-	-	
Mov Cap-1 Maneuver	1525	-	-	-	892 1009
Mov Cap-2 Maneuver	-	-	-	-	892 -
Stage 1	-	-	-	-	952 -
Stage 2	-	-	-	-	978 -

Approach	EB	WB	SB
HCM Control Delay, s	0.7	0	9.1
HCM LOS			A

Minor Lane/Major Mvmt	EBL	EBT	WBT	WBR	SBLn1
Capacity (veh/h)	1525	-	-	-	897
HCM Lane V/C Ratio	0.002	-	-	-	0.03
HCM Control Delay (s)	7.4	0	-	-	9.1
HCM Lane LOS	A	A	-	-	A
HCM 95th %tile Q(veh)	0	-	-	-	0.1

Intersection												
Int Delay, s/veh	4.1											
Movement	EBL	EBT	EBR	WBL	WBT	WBR	NBL	NBT	NBR	SBL	SBT	SBR
Lane Configurations		↕			↕			↕			↕	
Traffic Vol, veh/h	6	107	2	5	125	34	19	49	3	33	5	9
Future Vol, veh/h	6	107	2	5	125	34	19	49	3	33	5	9
Conflicting Peds, #/hr	3	0	6	6	0	3	2	0	2	2	0	2
Sign Control	Free	Free	Free	Free	Free	Free	Stop	Stop	Stop	Stop	Stop	Stop
RT Channelized	-	-	None	-	-	None	-	-	None	-	-	None
Storage Length	-	-	-	-	-	-	-	-	-	-	-	-
Veh in Median Storage, #	-	0	-	-	0	-	-	0	-	-	0	-
Grade, %	-	0	-	-	0	-	-	0	-	-	0	-
Peak Hour Factor	74	74	74	74	74	74	74	74	74	74	74	74
Heavy Vehicles, %	0	3	0	0	3	0	6	10	0	3	0	0
Mvmt Flow	8	145	3	7	169	46	26	66	4	45	7	12

Major/Minor	Major1			Major2			Minor1			Minor2		
Conflicting Flow All	218	0	0	154	0	0	387	401	155	409	379	197
Stage 1	-	-	-	-	-	-	169	169	-	209	209	-
Stage 2	-	-	-	-	-	-	218	232	-	200	170	-
Critical Hdwy	4.1	-	-	4.1	-	-	7.16	6.6	6.2	7.13	6.5	6.2
Critical Hdwy Stg 1	-	-	-	-	-	-	6.16	5.6	-	6.13	5.5	-
Critical Hdwy Stg 2	-	-	-	-	-	-	6.16	5.6	-	6.13	5.5	-
Follow-up Hdwy	2.2	-	-	2.2	-	-	3.554	4.09	3.3	3.527	4	3.3
Pot Cap-1 Maneuver	1364	-	-	1439	-	-	564	525	896	551	556	849
Stage 1	-	-	-	-	-	-	824	744	-	791	733	-
Stage 2	-	-	-	-	-	-	775	698	-	800	762	-
Platoon blocked, %	-	-	-	-	-	-	-	-	-	-	-	-
Mov Cap-1 Maneuver	1360	-	-	1431	-	-	541	514	889	488	544	845
Mov Cap-2 Maneuver	-	-	-	-	-	-	541	514	-	488	544	-
Stage 1	-	-	-	-	-	-	814	735	-	784	726	-
Stage 2	-	-	-	-	-	-	751	692	-	719	753	-

Approach	EB			WB			NB			SB		
HCM Control Delay, s	0.4			0.2			13.3			12.6		
HCM LOS							B			B		

Minor Lane/Major Mvmt	NBLn1	EBL	EBT	EBR	WBL	WBT	WBR	SBLn1
Capacity (veh/h)	531	1360	-	-	1431	-	-	537
HCM Lane V/C Ratio	0.181	0.006	-	-	0.005	-	-	0.118
HCM Control Delay (s)	13.3	7.7	0	-	7.5	0	-	12.6
HCM Lane LOS	B	A	A	-	A	A	-	B
HCM 95th %tile Q(veh)	0.7	0	-	-	0	-	-	0.4

Intersection												
Int Delay, s/veh	2.7											
Movement	EBL	EBT	EBR	WBL	WBT	WBR	NBL	NBT	NBR	SBL	SBT	SBR
Lane Configurations		↕			↕					↕		
Traffic Vol, veh/h	4	79	61	95	163	8	0	0	0	4	25	1
Future Vol, veh/h	4	79	61	95	163	8	0	0	0	4	25	1
Conflicting Peds, #/hr	0	0	2	2	0	0	0	0	0	0	0	0
Sign Control	Free	Free	Free	Free	Free	Free	Stop	Stop	Stop	Stop	Stop	Stop
RT Channelized	-	-	None	-	-	None	-	-	None	-	-	None
Storage Length	-	-	-	-	-	-	-	-	-	-	-	-
Veh in Median Storage, #	-	0	-	-	0	-	-	0	-	-	0	-
Grade, %	-	0	-	-	0	-	-	0	-	-	0	-
Peak Hour Factor	76	76	76	76	76	76	76	76	76	76	76	76
Heavy Vehicles, %	0	4	3	5	0	0	2	2	2	0	4	0
Mvmt Flow	5	104	80	125	214	11	0	0	0	5	33	1

Major/Minor	Major1			Major2			Minor2		
Conflicting Flow All	225	0	0	186	0	0	624	666	220
Stage 1	-	-	-	-	-	-	470	470	-
Stage 2	-	-	-	-	-	-	154	196	-
Critical Hdwy	4.1	-	-	4.15	-	-	6.4	6.54	6.2
Critical Hdwy Stg 1	-	-	-	-	-	-	5.4	5.54	-
Critical Hdwy Stg 2	-	-	-	-	-	-	5.4	5.54	-
Follow-up Hdwy	2.2	-	-	2.245	-	-	3.5	4.036	3.3
Pot Cap-1 Maneuver	1356	-	-	1371	-	-	452	378	825
Stage 1	-	-	-	-	-	-	633	557	-
Stage 2	-	-	-	-	-	-	879	735	-
Platoon blocked, %	-	-	-	-	-	-	-	-	-
Mov Cap-1 Maneuver	1356	-	-	1371	-	-	403	0	825
Mov Cap-2 Maneuver	-	-	-	-	-	-	403	0	-
Stage 1	-	-	-	-	-	-	630	0	-
Stage 2	-	-	-	-	-	-	788	0	-

Approach	EB	WB	SB
HCM Control Delay, s	0.2	2.8	13.8
HCM LOS			B

Minor Lane/Major Mvmt	EBL	EBT	EBR	WBL	WBT	WBR	SBLn1
Capacity (veh/h)	1356	-	-	1371	-	-	449
HCM Lane V/C Ratio	0.004	-	-	0.091	-	-	0.088
HCM Control Delay (s)	7.7	0	-	7.9	0	-	13.8
HCM Lane LOS	A	A	-	A	A	-	B
HCM 95th %tile Q(veh)	0	-	-	0.3	-	-	0.3

Intersection						
Int Delay, s/veh	0.9					
Movement	EBL	EBT	WBT	WBR	SBL	SBR
Lane Configurations		↕	↕		↕	
Traffic Vol, veh/h	5	29	59	66	10	2
Future Vol, veh/h	5	29	59	66	10	2
Conflicting Peds, #/hr	1	0	0	1	1	0
Sign Control	Free	Free	Free	Free	Stop	Stop
RT Channelized	-	None	-	None	-	None
Storage Length	-	-	-	-	0	-
Veh in Median Storage, #	-	0	0	-	0	-
Grade, %	-	0	0	-	0	-
Peak Hour Factor	58	58	58	58	58	58
Heavy Vehicles, %	0	4	2	8	0	0
Mvmt Flow	9	50	102	114	17	3

Major/Minor	Major1	Major2	Minor2		
Conflicting Flow All	217	0	-	0	229 160
Stage 1	-	-	-	-	160 -
Stage 2	-	-	-	-	69 -
Critical Hdwy	4.1	-	-	-	6.4 6.2
Critical Hdwy Stg 1	-	-	-	-	5.4 -
Critical Hdwy Stg 2	-	-	-	-	5.4 -
Follow-up Hdwy	2.2	-	-	-	3.5 3.3
Pot Cap-1 Maneuver	1365	-	-	-	764 890
Stage 1	-	-	-	-	874 -
Stage 2	-	-	-	-	959 -
Platoon blocked, %		-	-	-	
Mov Cap-1 Maneuver	1364	-	-	-	757 889
Mov Cap-2 Maneuver	-	-	-	-	757 -
Stage 1	-	-	-	-	867 -
Stage 2	-	-	-	-	958 -

Approach	EB	WB	SB
HCM Control Delay, s	1.1	0	9.8
HCM LOS			A

Minor Lane/Major Mvmt	EBL	EBT	WBT	WBR	SBLn1
Capacity (veh/h)	1364	-	-	-	776
HCM Lane V/C Ratio	0.006	-	-	-	0.027
HCM Control Delay (s)	7.7	0	-	-	9.8
HCM Lane LOS	A	A	-	-	A
HCM 95th %tile Q(veh)	0	-	-	-	0.1



Intersection												
Int Delay, s/veh	6.1											
Movement	EBL	EBT	EBR	WBL	WBT	WBR	NBL	NBT	NBR	SBL	SBT	SBR
Lane Configurations		↔			↔			↔			↔	
Traffic Vol, veh/h	0	16	23	29	27	0	97	86	0	0	180	1
Future Vol, veh/h	0	16	23	29	27	0	97	86	0	0	180	1
Conflicting Peds, #/hr	0	0	0	0	0	0	0	0	0	0	0	0
Sign Control	Stop	Stop	Stop	Stop	Stop	Stop	Free	Free	Free	Free	Free	Free
RT Channelized	-	-	None	-	-	None	-	-	None	-	-	None
Storage Length	-	-	-	-	-	-	-	-	-	-	-	-
Veh in Median Storage, #	-	0	-	-	0	-	-	0	-	-	0	-
Grade, %	-	0	-	-	0	-	-	0	-	-	0	-
Peak Hour Factor	61	61	61	61	61	61	61	61	61	61	61	61
Heavy Vehicles, %	0	0	0	0	6	0	4	0	8	0	3	100
Mvmt Flow	0	26	38	48	44	0	159	141	0	0	295	2

Major/Minor	Minor2		Minor1			Major1			Major2			
Conflicting Flow All	-	755	296	787	756	-	297	0	0	141	0	0
Stage 1	-	296	-	459	459	-	-	-	-	-	-	-
Stage 2	-	459	-	328	297	-	-	-	-	-	-	-
Critical Hdwy	-	6.5	6.2	7.1	6.56	-	4.14	-	-	4.1	-	-
Critical Hdwy Stg 1	-	5.5	-	6.1	5.56	-	-	-	-	-	-	-
Critical Hdwy Stg 2	-	5.5	-	6.1	5.56	-	-	-	-	-	-	-
Follow-up Hdwy	-	4	3.3	3.5	4.054	-	2.236	-	-	2.2	-	-
Pot Cap-1 Maneuver	0	340	748	312	333	0	1253	-	-	1455	-	-
Stage 1	0	672	-	586	560	0	-	-	-	-	-	-
Stage 2	0	570	-	689	660	0	-	-	-	-	-	-
Platoon blocked, %								-	-	-	-	-
Mov Cap-1 Maneuver	-	293	748	247	287	-	1253	-	-	1455	-	-
Mov Cap-2 Maneuver	-	293	-	247	287	-	-	-	-	-	-	-
Stage 1	-	672	-	505	483	-	-	-	-	-	-	-
Stage 2	-	491	-	629	660	-	-	-	-	-	-	-

Approach	EB		WB		NB		SB	
HCM Control Delay, s	14.2		25.6		4.4		0	
HCM LOS	B		D					

Minor Lane/Major Mvmt	NBL	NBT	NBR	EBLn1WBLn1	SBL	SBT	SBR
Capacity (veh/h)	1253	-	-	457	265	1455	-
HCM Lane V/C Ratio	0.127	-	-	0.14	0.346	-	-
HCM Control Delay (s)	8.3	0	-	14.2	25.6	0	-
HCM Lane LOS	A	A	-	B	D	A	-
HCM 95th %tile Q(veh)	0.4	-	-	0.5	1.5	0	-

Intersection												
Int Delay, s/veh	5.1											
Movement	EBL	EBT	EBR	WBL	WBT	WBR	NBL	NBT	NBR	SBL	SBT	SBR
Lane Configurations		↕			↕			↕			↕	
Traffic Vol, veh/h	21	179	4	2	126	30	22	76	6	35	18	14
Future Vol, veh/h	21	179	4	2	126	30	22	76	6	35	18	14
Conflicting Peds, #/hr	4	0	27	27	0	4	3	0	0	0	0	3
Sign Control	Free	Free	Free	Free	Free	Free	Stop	Stop	Stop	Stop	Stop	Stop
RT Channelized	-	-	None	-	-	None	-	-	None	-	-	None
Storage Length	-	-	-	-	-	-	-	-	-	-	-	-
Veh in Median Storage, #	-	0	-	-	0	-	-	0	-	-	0	-
Grade, %	-	0	-	-	0	-	-	0	-	-	0	-
Peak Hour Factor	85	85	85	85	85	85	85	85	85	85	85	85
Heavy Vehicles, %	0	2	0	0	2	2	3	5	0	1	7	0
Mvmt Flow	25	211	5	2	148	35	26	89	7	41	21	16

Major/Minor	Major1			Major2			Minor1			Minor2		
Conflicting Flow All	187	0	0	243	0	0	482	482	241	486	467	173
Stage 1	-	-	-	-	-	-	291	291	-	174	174	-
Stage 2	-	-	-	-	-	-	191	191	-	312	293	-
Critical Hdwy	4.1	-	-	4.1	-	-	7.13	6.55	6.2	7.11	6.57	6.2
Critical Hdwy Stg 1	-	-	-	-	-	-	6.13	5.55	-	6.11	5.57	-
Critical Hdwy Stg 2	-	-	-	-	-	-	6.13	5.55	-	6.11	5.57	-
Follow-up Hdwy	2.2	-	-	2.2	-	-	3.527	4.045	3.3	3.509	4.063	3.3
Pot Cap-1 Maneuver	1399	-	-	1335	-	-	493	480	803	493	486	876
Stage 1	-	-	-	-	-	-	715	666	-	830	746	-
Stage 2	-	-	-	-	-	-	808	737	-	701	661	-
Platoon blocked, %	-	-	-	-	-	-	-	-	-	-	-	-
Mov Cap-1 Maneuver	1394	-	-	1301	-	-	446	456	782	407	461	870
Mov Cap-2 Maneuver	-	-	-	-	-	-	446	456	-	407	461	-
Stage 1	-	-	-	-	-	-	683	636	-	810	742	-
Stage 2	-	-	-	-	-	-	766	733	-	585	631	-

Approach	EB			WB			NB			SB		
HCM Control Delay, s	0.8			0.1			15.5			14.1		
HCM LOS							C			B		

Minor Lane/Major Mvmt	NBLn1	EBL	EBT	EBR	WBL	WBT	WBR	SBLn1
Capacity (veh/h)	465	1394	-	-	1301	-	-	475
HCM Lane V/C Ratio	0.263	0.018	-	-	0.002	-	-	0.166
HCM Control Delay (s)	15.5	7.6	0	-	7.8	0	-	14.1
HCM Lane LOS	C	A	A	-	A	A	-	B
HCM 95th %tile Q(veh)	1	0.1	-	-	0	-	-	0.6

Intersection												
Int Delay, s/veh	1.5											
Movement	EBL	EBT	EBR	WBL	WBT	WBR	NBL	NBT	NBR	SBL	SBT	SBR
Lane Configurations		↕			↕						↕	
Traffic Vol, veh/h	2	169	49	28	157	9	0	0	0	8	28	1
Future Vol, veh/h	2	169	49	28	157	9	0	0	0	8	28	1
Conflicting Peds, #/hr	10	0	3	3	0	10	0	0	0	7	0	0
Sign Control	Free	Free	Free	Free	Free	Free	Stop	Stop	Stop	Stop	Stop	Stop
RT Channelized	-	-	None	-	-	None	-	-	None	-	-	None
Storage Length	-	-	-	-	-	-	-	-	-	-	-	-
Veh in Median Storage, #	-	0	-	-	0	-	-	0	-	-	0	-
Grade, %	-	0	-	-	0	-	-	0	-	-	0	-
Peak Hour Factor	98	98	98	98	98	98	98	98	98	98	98	98
Heavy Vehicles, %	0	2	4	11	2	0	0	2	2	6	0	0
Mvmt Flow	2	172	50	29	160	9	0	0	0	8	29	1

Major/Minor	Major1			Major2			Minor2			
Conflicting Flow All	179	0	0	225	0	0		441	462	175
Stage 1	-	-	-	-	-	-		233	233	-
Stage 2	-	-	-	-	-	-		208	229	-
Critical Hdwy	4.1	-	-	4.21	-	-		6.46	6.5	6.2
Critical Hdwy Stg 1	-	-	-	-	-	-		5.46	5.5	-
Critical Hdwy Stg 2	-	-	-	-	-	-		5.46	5.5	-
Follow-up Hdwy	2.2	-	-	2.299	-	-		3.554	4	3.3
Pot Cap-1 Maneuver	1409	-	-	1292	-	-		566	500	874
Stage 1	-	-	-	-	-	-		796	716	-
Stage 2	-	-	-	-	-	-		817	718	-
Platoon blocked, %		-	-	-	-	-				
Mov Cap-1 Maneuver	1396	-	-	1292	-	-		540	0	866
Mov Cap-2 Maneuver	-	-	-	-	-	-		540	0	-
Stage 1	-	-	-	-	-	-		786	0	-
Stage 2	-	-	-	-	-	-		789	0	-

Approach	EB		WB		SB	
HCM Control Delay, s	0.1		1.1		11.8	
HCM LOS					B	

Minor Lane/Major Mvmt	EBL	EBT	EBR	WBL	WBT	WBR	SBLn1
Capacity (veh/h)	1396	-	-	1292	-	-	564
HCM Lane V/C Ratio	0.001	-	-	0.022	-	-	0.067
HCM Control Delay (s)	7.6	0	-	7.8	0	-	11.8
HCM Lane LOS	A	A	-	A	A	-	B
HCM 95th %tile Q(veh)	0	-	-	0.1	-	-	0.2

Intersection						
Int Delay, s/veh	1.2					
Movement	EBL	EBT	WBT	WBR	SBL	SBR
Lane Configurations		↕	↕		↕	
Traffic Vol, veh/h	6	58	66	99	22	2
Future Vol, veh/h	6	58	66	99	22	2
Conflicting Peds, #/hr	9	0	0	9	0	0
Sign Control	Free	Free	Free	Free	Stop	Stop
RT Channelized	-	None	-	None	-	None
Storage Length	-	-	-	-	0	-
Veh in Median Storage, #	-	0	0	-	0	-
Grade, %	-	0	0	-	0	-
Peak Hour Factor	72	72	72	72	72	72
Heavy Vehicles, %	13	5	0	4	6	0
Mvmt Flow	8	81	92	138	31	3

Major/Minor	Major1	Major2	Minor2		
Conflicting Flow All	239	0	-	0	267
Stage 1	-	-	-	-	170
Stage 2	-	-	-	-	97
Critical Hdwy	4.23	-	-	-	6.46
Critical Hdwy Stg 1	-	-	-	-	5.46
Critical Hdwy Stg 2	-	-	-	-	5.46
Follow-up Hdwy	2.317	-	-	-	3.554
Pot Cap-1 Maneuver	1266	-	-	-	714
Stage 1	-	-	-	-	850
Stage 2	-	-	-	-	917
Platoon blocked, %		-	-	-	
Mov Cap-1 Maneuver	1255	-	-	-	696
Mov Cap-2 Maneuver	-	-	-	-	696
Stage 1	-	-	-	-	836
Stage 2	-	-	-	-	909

Approach	EB	WB	SB
HCM Control Delay, s	0.7	0	10.3
HCM LOS			B

Minor Lane/Major Mvmt	EBL	EBT	WBT	WBR	SBLn1
Capacity (veh/h)	1255	-	-	-	708
HCM Lane V/C Ratio	0.007	-	-	-	0.047
HCM Control Delay (s)	7.9	0	-	-	10.3
HCM Lane LOS	A	A	-	-	B
HCM 95th %tile Q(veh)	0	-	-	-	0.1

Intersection												
Int Delay, s/veh	5.9											
Movement	EBL	EBT	EBR	WBL	WBT	WBR	NBL	NBT	NBR	SBL	SBT	SBR
Lane Configurations		↔			↔			↔			↔	
Traffic Vol, veh/h	0	30	51	31	23	0	136	0	133	2	98	5
Future Vol, veh/h	0	30	51	31	23	0	136	0	133	2	98	5
Conflicting Peds, #/hr	0	0	0	0	0	0	0	0	0	0	0	0
Sign Control	Stop	Stop	Stop	Stop	Stop	Stop	Free	Free	Free	Free	Free	Free
RT Channelized	-	-	None	-	-	None	-	-	None	-	-	None
Storage Length	-	-	-	-	-	-	-	-	-	-	-	-
Veh in Median Storage, #	-	0	-	-	0	-	-	0	-	-	0	-
Grade, %	-	0	-	-	0	-	-	0	-	-	0	-
Peak Hour Factor	84	84	84	84	84	84	84	84	84	84	84	84
Heavy Vehicles, %	0	10	6	3	0	0	2	0	5	0	5	0
Mvmt Flow	0	36	61	37	27	0	162	0	158	2	117	6

Major/Minor	Minor2	Minor1			Major1			Major2				
Conflicting Flow All	-	606	120	576	530	-	123	0	0	158	0	0
Stage 1	-	124	-	403	403	-	-	-	-	-	-	-
Stage 2	-	482	-	173	127	-	-	-	-	-	-	-
Critical Hdwy	-	6.6	6.26	7.13	6.5	-	4.12	-	-	4.1	-	-
Critical Hdwy Stg 1	-	5.6	-	6.13	5.5	-	-	-	-	-	-	-
Critical Hdwy Stg 2	-	5.6	-	6.13	5.5	-	-	-	-	-	-	-
Follow-up Hdwy	-	4.09	3.354	3.527	4	-	2.218	-	-	2.2	-	-
Pot Cap-1 Maneuver	0	401	921	427	457	0	1464	-	-	1434	-	-
Stage 1	0	778	-	622	603	0	-	-	-	-	-	-
Stage 2	0	540	-	827	795	0	-	-	-	-	-	-
Platoon blocked, %								-	-	-	-	-
Mov Cap-1 Maneuver	-	351	921	333	400	-	1464	-	-	1434	-	-
Mov Cap-2 Maneuver	-	351	-	333	400	-	-	-	-	-	-	-
Stage 1	-	777	-	545	528	-	-	-	-	-	-	-
Stage 2	-	473	-	736	794	-	-	-	-	-	-	-

Approach	EB	WB	NB	SB
HCM Control Delay, s	12.5	17.2	3.9	0.1
HCM LOS	B	C		

Minor Lane/Major Mvmt	NBL	NBT	NBR	EBLn1WBLn1	SBL	SBT	SBR
Capacity (veh/h)	1464	-	-	575	359	1434	-
HCM Lane V/C Ratio	0.111	-	-	0.168	0.179	0.002	-
HCM Control Delay (s)	7.8	0	-	12.5	17.2	7.5	0
HCM Lane LOS	A	A	-	B	C	A	A
HCM 95th %tile Q(veh)	0.4	-	-	0.6	0.6	0	-

Intersection												
Int Delay, s/veh	3.1											
Movement	EBL	EBT	EBR	WBL	WBT	WBR	NBL	NBT	NBR	SBL	SBT	SBR
Lane Configurations		↕			↕			↕			↕	
Traffic Vol, veh/h	19	188	4	5	153	20	25	24	6	30	7	13
Future Vol, veh/h	19	188	4	5	153	20	25	24	6	30	7	13
Conflicting Peds, #/hr	2	0	4	4	0	2	2	0	1	1	0	2
Sign Control	Free	Free	Free	Free	Free	Free	Stop	Stop	Stop	Stop	Stop	Stop
RT Channelized	-	-	None	-	-	None	-	-	None	-	-	None
Storage Length	-	-	-	-	-	-	-	-	-	-	-	-
Veh in Median Storage, #	-	0	-	-	0	-	-	0	-	-	0	-
Grade, %	-	0	-	-	0	-	-	0	-	-	0	-
Peak Hour Factor	90	90	90	90	90	90	90	90	90	90	90	90
Heavy Vehicles, %	6	2	0	0	4	0	4	0	0	0	0	8
Mvmt Flow	21	209	4	6	170	22	28	27	7	33	8	14

Major/Minor	Major1			Major2			Minor1			Minor2		
Conflicting Flow All	194	0	0	217	0	0	463	463	216	466	454	185
Stage 1	-	-	-	-	-	-	257	257	-	195	195	-
Stage 2	-	-	-	-	-	-	206	206	-	271	259	-
Critical Hdwy	4.16	-	-	4.1	-	-	7.14	6.5	6.2	7.1	6.5	6.28
Critical Hdwy Stg 1	-	-	-	-	-	-	6.14	5.5	-	6.1	5.5	-
Critical Hdwy Stg 2	-	-	-	-	-	-	6.14	5.5	-	6.1	5.5	-
Follow-up Hdwy	2.254	-	-	2.2	-	-	3.536	4	3.3	3.5	4	3.372
Pot Cap-1 Maneuver	1355	-	-	1365	-	-	506	499	829	510	505	842
Stage 1	-	-	-	-	-	-	743	699	-	811	743	-
Stage 2	-	-	-	-	-	-	791	735	-	739	697	-
Platoon blocked, %	-	-	-	-	-	-	-	-	-	-	-	-
Mov Cap-1 Maneuver	1352	-	-	1360	-	-	480	485	825	475	490	839
Mov Cap-2 Maneuver	-	-	-	-	-	-	480	485	-	475	490	-
Stage 1	-	-	-	-	-	-	727	684	-	795	738	-
Stage 2	-	-	-	-	-	-	764	730	-	691	682	-

Approach	EB			WB			NB			SB		
HCM Control Delay, s	0.7			0.2			13.1			12.5		
HCM LOS							B			B		

Minor Lane/Major Mvmt	NBLn1	EBL	EBT	EBR	WBL	WBT	WBR	SBLn1
Capacity (veh/h)	505	1352	-	-	1360	-	-	538
HCM Lane V/C Ratio	0.121	0.016	-	-	0.004	-	-	0.103
HCM Control Delay (s)	13.1	7.7	0	-	7.7	0	-	12.5
HCM Lane LOS	B	A	A	-	A	A	-	B
HCM 95th %tile Q(veh)	0.4	0	-	-	0	-	-	0.3

Intersection						
Int Delay, s/veh	1.2					
Movement	EBL	EBT	WBT	WBR	SBL	SBR
Lane Configurations		↶	↷		↶	↷
Traffic Vol, veh/h	6	46	40	49	13	3
Future Vol, veh/h	6	46	40	49	13	3
Conflicting Peds, #/hr	4	0	0	0	0	0
Sign Control	Free	Free	Free	Free	Stop	Stop
RT Channelized	-	None	-	None	-	None
Storage Length	-	-	-	-	0	-
Veh in Median Storage, #	-	0	0	-	0	-
Grade, %	-	0	0	-	0	-
Peak Hour Factor	89	89	89	89	89	89
Heavy Vehicles, %	0	2	4	1	0	0
Mvmt Flow	7	52	45	55	15	3

Major/Minor	Major1	Major2	Minor2		
Conflicting Flow All	104	0	-	0	143 77
Stage 1	-	-	-	-	77 -
Stage 2	-	-	-	-	66 -
Critical Hdwy	4.1	-	-	-	6.4 6.2
Critical Hdwy Stg 1	-	-	-	-	5.4 -
Critical Hdwy Stg 2	-	-	-	-	5.4 -
Follow-up Hdwy	2.2	-	-	-	3.5 3.3
Pot Cap-1 Maneuver	1500	-	-	-	854 990
Stage 1	-	-	-	-	951 -
Stage 2	-	-	-	-	962 -
Platoon blocked, %		-	-	-	
Mov Cap-1 Maneuver	1494	-	-	-	843 986
Mov Cap-2 Maneuver	-	-	-	-	843 -
Stage 1	-	-	-	-	942 -
Stage 2	-	-	-	-	958 -

Approach	EB	WB	SB
HCM Control Delay, s	0.9	0	9.2
HCM LOS			A

Minor Lane/Major Mvmt	EBL	EBT	WBT	WBR	SBLn1
Capacity (veh/h)	1494	-	-	-	867
HCM Lane V/C Ratio	0.005	-	-	-	0.021
HCM Control Delay (s)	7.4	0	-	-	9.2
HCM Lane LOS	A	A	-	-	A
HCM 95th %tile Q(veh)	0	-	-	-	0.1

Intersection												
Int Delay, s/veh	2.5											
Movement	EBL	EBT	EBR	WBL	WBT	WBR	NBL	NBT	NBR	SBL	SBT	SBR
Lane Configurations		↕			↕			↕			↕	
Traffic Vol, veh/h	8	153	4	3	157	12	11	20	1	23	12	16
Future Vol, veh/h	8	153	4	3	157	12	11	20	1	23	12	16
Conflicting Peds, #/hr	4	0	27	27	0	4	3	0	0	0	0	3
Sign Control	Free	Free	Free	Free	Free	Free	Stop	Stop	Stop	Stop	Stop	Stop
RT Channelized	-	-	None	-	-	None	-	-	None	-	-	None
Storage Length	-	-	-	-	-	-	-	-	-	-	-	-
Veh in Median Storage, #	-	0	-	-	0	-	-	0	-	-	0	-
Grade, %	-	0	-	-	0	-	-	0	-	-	0	-
Peak Hour Factor	92	92	92	92	92	92	92	92	92	92	92	92
Heavy Vehicles, %	0	3	50	0	4	0	0	0	0	0	0	0
Mvmt Flow	9	166	4	3	171	13	12	22	1	25	13	17

Major/Minor	Major1			Major2			Minor1			Minor2		
Conflicting Flow All	188	0	0	197	0	0	415	407	195	386	403	185
Stage 1	-	-	-	-	-	-	213	213	-	188	188	-
Stage 2	-	-	-	-	-	-	202	194	-	198	215	-
Critical Hdwy	4.1	-	-	4.1	-	-	7.1	6.5	6.2	7.1	6.5	6.2
Critical Hdwy Stg 1	-	-	-	-	-	-	6.1	5.5	-	6.1	5.5	-
Critical Hdwy Stg 2	-	-	-	-	-	-	6.1	5.5	-	6.1	5.5	-
Follow-up Hdwy	2.2	-	-	2.2	-	-	3.5	4	3.3	3.5	4	3.3
Pot Cap-1 Maneuver	1398	-	-	1388	-	-	551	537	851	576	539	862
Stage 1	-	-	-	-	-	-	794	730	-	818	748	-
Stage 2	-	-	-	-	-	-	805	744	-	808	729	-
Platoon blocked, %	-	-	-	-	-	-	-	-	-	-	-	-
Mov Cap-1 Maneuver	1393	-	-	1352	-	-	511	516	829	551	518	856
Mov Cap-2 Maneuver	-	-	-	-	-	-	511	516	-	551	518	-
Stage 1	-	-	-	-	-	-	768	706	-	809	744	-
Stage 2	-	-	-	-	-	-	771	740	-	777	705	-

Approach	EB			WB			NB			SB		
HCM Control Delay, s	0.4			0.1			12.4			11.5		
HCM LOS							B			B		

Minor Lane/Major Mvmt	NBLn1	EBL	EBT	EBR	WBL	WBT	WBR	SBLn1
Capacity (veh/h)	520	1393	-	-	1352	-	-	610
HCM Lane V/C Ratio	0.067	0.006	-	-	0.002	-	-	0.091
HCM Control Delay (s)	12.4	7.6	0	-	7.7	0	-	11.5
HCM Lane LOS	B	A	A	-	A	A	-	B
HCM 95th %tile Q(veh)	0.2	0	-	-	0	-	-	0.3



**Intersection**

Int Delay, s/veh 1.6

Movement	EBL	EBT	WBT	WBR	SBL	SBR
Lane Configurations		↕	↕		↕	
Traffic Vol, veh/h	2	31	35	30	18	1
Future Vol, veh/h	2	31	35	30	18	1
Conflicting Peds, #/hr	5	0	0	0	0	0
Sign Control	Free	Free	Free	Free	Stop	Stop
RT Channelized	-	None	-	None	-	None
Storage Length	-	-	-	-	0	-
Veh in Median Storage, #	-	0	0	-	0	-
Grade, %	-	0	0	-	0	-
Peak Hour Factor	71	71	71	71	71	71
Heavy Vehicles, %	0	2	1	1	4	0
Mvmt Flow	3	44	49	42	25	1

Major/Minor	Major1	Major2	Minor2		
Conflicting Flow All	96	0	-	0	125 75
Stage 1	-	-	-	-	75 -
Stage 2	-	-	-	-	50 -
Critical Hdwy	4.1	-	-	-	6.44 6.2
Critical Hdwy Stg 1	-	-	-	-	5.44 -
Critical Hdwy Stg 2	-	-	-	-	5.44 -
Follow-up Hdwy	2.2	-	-	-	3.536 3.3
Pot Cap-1 Maneuver	1510	-	-	-	865 992
Stage 1	-	-	-	-	943 -
Stage 2	-	-	-	-	967 -
Platoon blocked, %		-	-	-	
Mov Cap-1 Maneuver	1503	-	-	-	855 987
Mov Cap-2 Maneuver	-	-	-	-	855 -
Stage 1	-	-	-	-	936 -
Stage 2	-	-	-	-	962 -

Approach	EB	WB	SB
HCM Control Delay, s	0.4	0	9.3
HCM LOS			A

Minor Lane/Major Mvmt	EBL	EBT	WBT	WBR	SBLn1
Capacity (veh/h)	1503	-	-	-	861
HCM Lane V/C Ratio	0.002	-	-	-	0.031
HCM Control Delay (s)	7.4	0	-	-	9.3
HCM Lane LOS	A	A	-	-	A
HCM 95th %tile Q(veh)	0	-	-	-	0.1

Intersection												
Int Delay, s/veh	4.2											
Movement	EBL	EBT	EBR	WBL	WBT	WBR	NBL	NBT	NBR	SBL	SBT	SBR
Lane Configurations		↕			↕			↕			↕	
Traffic Vol, veh/h	6	107	3	5	125	34	21	50	4	33	5	9
Future Vol, veh/h	6	107	3	5	125	34	21	50	4	33	5	9
Conflicting Peds, #/hr	3	0	6	6	0	3	2	0	2	2	0	2
Sign Control	Free	Free	Free	Free	Free	Free	Stop	Stop	Stop	Stop	Stop	Stop
RT Channelized	-	-	None	-	-	None	-	-	None	-	-	None
Storage Length	-	-	-	-	-	-	-	-	-	-	-	-
Veh in Median Storage, #	-	0	-	-	0	-	-	0	-	-	0	-
Grade, %	-	0	-	-	0	-	-	0	-	-	0	-
Peak Hour Factor	74	74	74	74	74	74	74	74	74	74	74	74
Heavy Vehicles, %	0	3	0	0	3	0	6	10	0	3	0	0
Mvmt Flow	8	145	4	7	169	46	28	68	5	45	7	12

Major/Minor	Major1			Major2			Minor1			Minor2		
Conflicting Flow All	218	0	0	155	0	0	387	401	155	411	380	197
Stage 1	-	-	-	-	-	-	169	169	-	209	209	-
Stage 2	-	-	-	-	-	-	218	232	-	202	171	-
Critical Hdwy	4.1	-	-	4.1	-	-	7.16	6.6	6.2	7.13	6.5	6.2
Critical Hdwy Stg 1	-	-	-	-	-	-	6.16	5.6	-	6.13	5.5	-
Critical Hdwy Stg 2	-	-	-	-	-	-	6.16	5.6	-	6.13	5.5	-
Follow-up Hdwy	2.2	-	-	2.2	-	-	3.554	4.09	3.3	3.527	4	3.3
Pot Cap-1 Maneuver	1364	-	-	1438	-	-	564	525	896	549	556	849
Stage 1	-	-	-	-	-	-	824	744	-	791	733	-
Stage 2	-	-	-	-	-	-	775	698	-	798	761	-
Platoon blocked, %	-	-	-	-	-	-	-	-	-	-	-	-
Mov Cap-1 Maneuver	1360	-	-	1430	-	-	541	514	889	484	544	845
Mov Cap-2 Maneuver	-	-	-	-	-	-	541	514	-	484	544	-
Stage 1	-	-	-	-	-	-	814	735	-	784	726	-
Stage 2	-	-	-	-	-	-	751	692	-	715	752	-

Approach	EB			WB			NB			SB		
HCM Control Delay, s	0.4			0.2			13.3			12.7		
HCM LOS							B			B		

Minor Lane/Major Mvmt	NBLn1	EBL	EBT	EBR	WBL	WBT	WBR	SBLn1
Capacity (veh/h)	533	1360	-	-	1430	-	-	534
HCM Lane V/C Ratio	0.19	0.006	-	-	0.005	-	-	0.119
HCM Control Delay (s)	13.3	7.7	0	-	7.5	0	-	12.7
HCM Lane LOS	B	A	A	-	A	A	-	B
HCM 95th %tile Q(veh)	0.7	0	-	-	0	-	-	0.4

Intersection												
Int Delay, s/veh	2.7											
Movement	EBL	EBT	EBR	WBL	WBT	WBR	NBL	NBT	NBR	SBL	SBT	SBR
Lane Configurations		↕			↕					↕		
Traffic Vol, veh/h	4	80	61	95	163	8	0	0	0	4	25	1
Future Vol, veh/h	4	80	61	95	163	8	0	0	0	4	25	1
Conflicting Peds, #/hr	0	0	2	2	0	0	0	0	0	0	0	0
Sign Control	Free	Free	Free	Free	Free	Free	Stop	Stop	Stop	Stop	Stop	Stop
RT Channelized	-	-	None	-	-	None	-	-	None	-	-	None
Storage Length	-	-	-	-	-	-	-	-	-	-	-	-
Veh in Median Storage, #	-	0	-	-	0	-	-	0	-	-	0	-
Grade, %	-	0	-	-	0	-	-	0	-	-	0	-
Peak Hour Factor	76	76	76	76	76	76	76	76	76	76	76	76
Heavy Vehicles, %	0	4	3	5	0	0	2	2	2	0	4	0
Mvmt Flow	5	105	80	125	214	11	0	0	0	5	33	1

Major/Minor	Major1			Major2			Minor2		
Conflicting Flow All	225	0	0	187	0	0	625	667	220
Stage 1	-	-	-	-	-	-	470	470	-
Stage 2	-	-	-	-	-	-	155	197	-
Critical Hdwy	4.1	-	-	4.15	-	-	6.4	6.54	6.2
Critical Hdwy Stg 1	-	-	-	-	-	-	5.4	5.54	-
Critical Hdwy Stg 2	-	-	-	-	-	-	5.4	5.54	-
Follow-up Hdwy	2.2	-	-	2.245	-	-	3.5	4.036	3.3
Pot Cap-1 Maneuver	1356	-	-	1369	-	-	452	377	825
Stage 1	-	-	-	-	-	-	633	557	-
Stage 2	-	-	-	-	-	-	878	734	-
Platoon blocked, %	-	-	-	-	-	-	-	-	-
Mov Cap-1 Maneuver	1356	-	-	1369	-	-	403	0	825
Mov Cap-2 Maneuver	-	-	-	-	-	-	403	0	-
Stage 1	-	-	-	-	-	-	630	0	-
Stage 2	-	-	-	-	-	-	787	0	-

Approach	EB		WB		SB	
HCM Control Delay, s	0.2		2.8		13.8	
HCM LOS					B	

Minor Lane/Major Mvmt	EBL	EBT	EBR	WBL	WBT	WBR	SBLn1
Capacity (veh/h)	1356	-	-	1369	-	-	449
HCM Lane V/C Ratio	0.004	-	-	0.091	-	-	0.088
HCM Control Delay (s)	7.7	0	-	7.9	0	-	13.8
HCM Lane LOS	A	A	-	A	A	-	B
HCM 95th %tile Q(veh)	0	-	-	0.3	-	-	0.3

Intersection						
Int Delay, s/veh	0.9					
Movement	EBL	EBT	WBT	WBR	SBL	SBR
Lane Configurations		↕	↕		↕	
Traffic Vol, veh/h	5	29	59	66	10	2
Future Vol, veh/h	5	29	59	66	10	2
Conflicting Peds, #/hr	1	0	0	1	1	0
Sign Control	Free	Free	Free	Free	Stop	Stop
RT Channelized	-	None	-	None	-	None
Storage Length	-	-	-	-	0	-
Veh in Median Storage, #	-	0	0	-	0	-
Grade, %	-	0	0	-	0	-
Peak Hour Factor	58	58	58	58	58	58
Heavy Vehicles, %	0	4	2	8	0	0
Mvmt Flow	9	50	102	114	17	3

Major/Minor	Major1	Major2	Minor2		
Conflicting Flow All	217	0	-	0	229 160
Stage 1	-	-	-	-	160 -
Stage 2	-	-	-	-	69 -
Critical Hdwy	4.1	-	-	-	6.4 6.2
Critical Hdwy Stg 1	-	-	-	-	5.4 -
Critical Hdwy Stg 2	-	-	-	-	5.4 -
Follow-up Hdwy	2.2	-	-	-	3.5 3.3
Pot Cap-1 Maneuver	1365	-	-	-	764 890
Stage 1	-	-	-	-	874 -
Stage 2	-	-	-	-	959 -
Platoon blocked, %		-	-	-	
Mov Cap-1 Maneuver	1364	-	-	-	757 889
Mov Cap-2 Maneuver	-	-	-	-	757 -
Stage 1	-	-	-	-	867 -
Stage 2	-	-	-	-	958 -

Approach	EB	WB	SB
HCM Control Delay, s	1.1	0	9.8
HCM LOS			A

Minor Lane/Major Mvmt	EBL	EBT	WBT	WBR	SBLn1
Capacity (veh/h)	1364	-	-	-	776
HCM Lane V/C Ratio	0.006	-	-	-	0.027
HCM Control Delay (s)	7.7	0	-	-	9.8
HCM Lane LOS	A	A	-	-	A
HCM 95th %tile Q(veh)	0	-	-	-	0.1

Intersection												
Int Delay, s/veh	6.1											
Movement	EBL	EBT	EBR	WBL	WBT	WBR	NBL	NBT	NBR	SBL	SBT	SBR
Lane Configurations		↔			↔			↔			↔	
Traffic Vol, veh/h	0	16	23	29	27	0	97	86	0	0	180	1
Future Vol, veh/h	0	16	23	29	27	0	97	86	0	0	180	1
Conflicting Peds, #/hr	0	0	0	0	0	0	0	0	0	0	0	0
Sign Control	Stop	Stop	Stop	Stop	Stop	Stop	Free	Free	Free	Free	Free	Free
RT Channelized	-	-	None	-	-	None	-	-	None	-	-	None
Storage Length	-	-	-	-	-	-	-	-	-	-	-	-
Veh in Median Storage, #	-	0	-	-	0	-	-	0	-	-	0	-
Grade, %	-	0	-	-	0	-	-	0	-	-	0	-
Peak Hour Factor	61	61	61	61	61	61	61	61	61	61	61	61
Heavy Vehicles, %	0	0	0	0	6	0	4	0	8	0	3	100
Mvmt Flow	0	26	38	48	44	0	159	141	0	0	295	2

Major/Minor	Minor2		Minor1		Major1		Major2					
Conflicting Flow All	-	755	296	787	756	-	297	0	0	141	0	0
Stage 1	-	296	-	459	459	-	-	-	-	-	-	-
Stage 2	-	459	-	328	297	-	-	-	-	-	-	-
Critical Hdwy	-	6.5	6.2	7.1	6.56	-	4.14	-	-	4.1	-	-
Critical Hdwy Stg 1	-	5.5	-	6.1	5.56	-	-	-	-	-	-	-
Critical Hdwy Stg 2	-	5.5	-	6.1	5.56	-	-	-	-	-	-	-
Follow-up Hdwy	-	4	3.3	3.5	4.054	-	2.236	-	-	2.2	-	-
Pot Cap-1 Maneuver	0	340	748	312	333	0	1253	-	-	1455	-	-
Stage 1	0	672	-	586	560	0	-	-	-	-	-	-
Stage 2	0	570	-	689	660	0	-	-	-	-	-	-
Platoon blocked, %								-	-	-	-	-
Mov Cap-1 Maneuver	-	293	748	247	287	-	1253	-	-	1455	-	-
Mov Cap-2 Maneuver	-	293	-	247	287	-	-	-	-	-	-	-
Stage 1	-	672	-	505	483	-	-	-	-	-	-	-
Stage 2	-	491	-	629	660	-	-	-	-	-	-	-

Approach	EB		WB		NB		SB			
HCM Control Delay, s	14.2		25.6		4.4		0			
HCM LOS	B		D							

Minor Lane/Major Mvmt	NBL	NBT	NBR	EBLn1WBLn1	SBL	SBT	SBR
Capacity (veh/h)	1253	-	-	457	265	1455	-
HCM Lane V/C Ratio	0.127	-	-	0.14	0.346	-	-
HCM Control Delay (s)	8.3	0	-	14.2	25.6	0	-
HCM Lane LOS	A	A	-	B	D	A	-
HCM 95th %tile Q(veh)	0.4	-	-	0.5	1.5	0	-

Intersection						
Int Delay, s/veh	0.1					
Movement	EBL	EBR	NBL	NBT	SBT	SBR
Lane Configurations	T			T		T
Traffic Vol, veh/h	1	0	0	73	13	0
Future Vol, veh/h	1	0	0	73	13	0
Conflicting Peds, #/hr	0	0	0	0	0	0
Sign Control	Stop	Stop	Free	Free	Free	Free
RT Channelized	-	None	-	None	-	None
Storage Length	0	-	-	-	-	-
Veh in Median Storage, #	0	-	-	0	0	-
Grade, %	0	-	-	0	0	-
Peak Hour Factor	58	58	58	58	58	58
Heavy Vehicles, %	0	0	0	7	0	0
Mvmt Flow	2	0	0	126	22	0

Major/Minor	Minor2	Major1		Major2	
Conflicting Flow All	148	22	22	0	0
Stage 1	22	-	-	-	-
Stage 2	126	-	-	-	-
Critical Hdwy	6.4	6.2	4.1	-	-
Critical Hdwy Stg 1	5.4	-	-	-	-
Critical Hdwy Stg 2	5.4	-	-	-	-
Follow-up Hdwy	3.5	3.3	2.2	-	-
Pot Cap-1 Maneuver	849	1061	1607	-	-
Stage 1	1006	-	-	-	-
Stage 2	905	-	-	-	-
Platoon blocked, %				-	-
Mov Cap-1 Maneuver	849	1061	1607	-	-
Mov Cap-2 Maneuver	849	-	-	-	-
Stage 1	1006	-	-	-	-
Stage 2	905	-	-	-	-

Approach	EB	NB	SB
HCM Control Delay, s	9.2	0	0
HCM LOS	A		

Minor Lane/Major Mvmt	NBL	NBT	EBLn1	SBT	SBR
Capacity (veh/h)	1607	-	849	-	-
HCM Lane V/C Ratio	-	-	0.002	-	-
HCM Control Delay (s)	0	-	9.2	-	-
HCM Lane LOS	A	-	A	-	-
HCM 95th %tile Q(veh)	0	-	0	-	-

Intersection						
Int Delay, s/veh	0.1					
Movement	EBL	EBR	NBL	NBT	SBT	SBR
Lane Configurations	T			T		T
Traffic Vol, veh/h	1	0	0	73	13	0
Future Vol, veh/h	1	0	0	73	13	0
Conflicting Peds, #/hr	0	0	0	0	0	0
Sign Control	Stop	Stop	Free	Free	Free	Free
RT Channelized	-	None	-	None	-	None
Storage Length	0	-	-	-	-	-
Veh in Median Storage, #	0	-	-	0	0	-
Grade, %	0	-	-	0	0	-
Peak Hour Factor	58	58	58	58	58	58
Heavy Vehicles, %	0	0	0	7	0	0
Mvmt Flow	2	0	0	126	22	0

Major/Minor	Minor2	Major1		Major2	
Conflicting Flow All	148	22	22	0	0
Stage 1	22	-	-	-	-
Stage 2	126	-	-	-	-
Critical Hdwy	6.4	6.2	4.1	-	-
Critical Hdwy Stg 1	5.4	-	-	-	-
Critical Hdwy Stg 2	5.4	-	-	-	-
Follow-up Hdwy	3.5	3.3	2.2	-	-
Pot Cap-1 Maneuver	849	1061	1607	-	-
Stage 1	1006	-	-	-	-
Stage 2	905	-	-	-	-
Platoon blocked, %				-	-
Mov Cap-1 Maneuver	849	1061	1607	-	-
Mov Cap-2 Maneuver	849	-	-	-	-
Stage 1	1006	-	-	-	-
Stage 2	905	-	-	-	-

Approach	EB	NB	SB
HCM Control Delay, s	9.2	0	0
HCM LOS	A		

Minor Lane/Major Mvmt	NBL	NBT	EBLn1	SBT	SBR
Capacity (veh/h)	1607	-	849	-	-
HCM Lane V/C Ratio	-	-	0.002	-	-
HCM Control Delay (s)	0	-	9.2	-	-
HCM Lane LOS	A	-	A	-	-
HCM 95th %tile Q(veh)	0	-	0	-	-

Intersection						
Int Delay, s/veh	0.3					
Movement	EBL	EBR	NBL	NBT	SBT	SBR
Lane Configurations	T			T		T
Traffic Vol, veh/h	2	1	0	71	12	1
Future Vol, veh/h	2	1	0	71	12	1
Conflicting Peds, #/hr	0	0	0	0	0	0
Sign Control	Stop	Stop	Free	Free	Free	Free
RT Channelized	-	None	-	None	-	None
Storage Length	0	-	-	-	-	-
Veh in Median Storage, #	0	-	-	0	0	-
Grade, %	0	-	-	0	0	-
Peak Hour Factor	58	58	58	58	58	58
Heavy Vehicles, %	0	0	0	7	0	0
Mvmt Flow	3	2	0	122	21	2

Major/Minor	Minor2	Major1		Major2	
Conflicting Flow All	144	22	23	0	0
Stage 1	22	-	-	-	-
Stage 2	122	-	-	-	-
Critical Hdwy	6.4	6.2	4.1	-	-
Critical Hdwy Stg 1	5.4	-	-	-	-
Critical Hdwy Stg 2	5.4	-	-	-	-
Follow-up Hdwy	3.5	3.3	2.2	-	-
Pot Cap-1 Maneuver	853	1061	1605	-	-
Stage 1	1006	-	-	-	-
Stage 2	908	-	-	-	-
Platoon blocked, %				-	-
Mov Cap-1 Maneuver	853	1061	1605	-	-
Mov Cap-2 Maneuver	853	-	-	-	-
Stage 1	1006	-	-	-	-
Stage 2	908	-	-	-	-

Approach	EB	NB	SB
HCM Control Delay, s	9	0	0
HCM LOS	A		

Minor Lane/Major Mvmt	NBL	NBT	EBLn1	SBT	SBR
Capacity (veh/h)	1605	-	913	-	-
HCM Lane V/C Ratio	-	-	0.006	-	-
HCM Control Delay (s)	0	-	9	-	-
HCM Lane LOS	A	-	A	-	-
HCM 95th %tile Q(veh)	0	-	0	-	-



Intersection						
Int Delay, s/veh	0.1					
Movement	EBL	EBT	WBT	WBR	SBL	SBR
Lane Configurations		↶	↷		↶	
Traffic Vol, veh/h	0	34	62	0	0	1
Future Vol, veh/h	0	34	62	0	0	1
Conflicting Peds, #/hr	0	0	0	0	0	0
Sign Control	Free	Free	Free	Free	Stop	Stop
RT Channelized	-	None	-	None	-	None
Storage Length	-	-	-	-	0	-
Veh in Median Storage, #	-	0	0	-	0	-
Grade, %	-	0	0	-	0	-
Peak Hour Factor	58	58	58	58	58	58
Heavy Vehicles, %	0	4	2	0	0	0
Mvmt Flow	0	59	107	0	0	2

Major/Minor	Major1	Major2	Minor2		
Conflicting Flow All	107	0	-	0	166 107
Stage 1	-	-	-	-	107 -
Stage 2	-	-	-	-	59 -
Critical Hdwy	4.1	-	-	-	6.4 6.2
Critical Hdwy Stg 1	-	-	-	-	5.4 -
Critical Hdwy Stg 2	-	-	-	-	5.4 -
Follow-up Hdwy	2.2	-	-	-	3.5 3.3
Pot Cap-1 Maneuver	1497	-	-	-	829 953
Stage 1	-	-	-	-	922 -
Stage 2	-	-	-	-	969 -
Platoon blocked, %		-	-	-	
Mov Cap-1 Maneuver	1497	-	-	-	829 953
Mov Cap-2 Maneuver	-	-	-	-	829 -
Stage 1	-	-	-	-	922 -
Stage 2	-	-	-	-	969 -

Approach	EB	WB	SB
HCM Control Delay, s	0	0	8.8
HCM LOS			A

Minor Lane/Major Mvmt	EBL	EBT	WBT	WBR	SBLn1
Capacity (veh/h)	1497	-	-	-	953
HCM Lane V/C Ratio	-	-	-	-	0.002
HCM Control Delay (s)	0	-	-	-	8.8
HCM Lane LOS	A	-	-	-	A
HCM 95th %tile Q(veh)	0	-	-	-	0

Intersection						
Int Delay, s/veh	0.1					
Movement	EBL	EBT	WBT	WBR	SBL	SBR
Lane Configurations		↶	↷		↶	
Traffic Vol, veh/h	0	34	63	0	0	1
Future Vol, veh/h	0	34	63	0	0	1
Conflicting Peds, #/hr	0	0	0	0	0	0
Sign Control	Free	Free	Free	Free	Stop	Stop
RT Channelized	-	None	-	None	-	None
Storage Length	-	-	-	-	0	-
Veh in Median Storage, #	-	0	0	-	0	-
Grade, %	-	0	0	-	0	-
Peak Hour Factor	58	58	58	58	58	58
Heavy Vehicles, %	0	4	2	0	0	0
Mvmt Flow	0	59	109	0	0	2

Major/Minor	Major1	Major2	Minor2		
Conflicting Flow All	109	0	-	0	168
Stage 1	-	-	-	-	109
Stage 2	-	-	-	-	59
Critical Hdwy	4.1	-	-	-	6.4
Critical Hdwy Stg 1	-	-	-	-	5.4
Critical Hdwy Stg 2	-	-	-	-	5.4
Follow-up Hdwy	2.2	-	-	-	3.5
Pot Cap-1 Maneuver	1494	-	-	-	827
Stage 1	-	-	-	-	921
Stage 2	-	-	-	-	969
Platoon blocked, %		-	-	-	
Mov Cap-1 Maneuver	1494	-	-	-	827
Mov Cap-2 Maneuver	-	-	-	-	827
Stage 1	-	-	-	-	921
Stage 2	-	-	-	-	969

Approach	EB	WB	SB
HCM Control Delay, s	0	0	8.8
HCM LOS			A

Minor Lane/Major Mvmt	EBL	EBT	WBT	WBR	SBLn1
Capacity (veh/h)	1494	-	-	-	950
HCM Lane V/C Ratio	-	-	-	-	0.002
HCM Control Delay (s)	0	-	-	-	8.8
HCM Lane LOS	A	-	-	-	A
HCM 95th %tile Q(veh)	0	-	-	-	0

Intersection												
Int Delay, s/veh	5.2											
Movement	EBL	EBT	EBR	WBL	WBT	WBR	NBL	NBT	NBR	SBL	SBT	SBR
Lane Configurations		↕			↕			↕			↕	
Traffic Vol, veh/h	21	179	6	3	126	30	23	76	6	35	19	14
Future Vol, veh/h	21	179	6	3	126	30	23	76	6	35	19	14
Conflicting Peds, #/hr	4	0	27	27	0	4	3	0	0	0	0	3
Sign Control	Free	Free	Free	Free	Free	Free	Stop	Stop	Stop	Stop	Stop	Stop
RT Channelized	-	-	None	-	-	None	-	-	None	-	-	None
Storage Length	-	-	-	-	-	-	-	-	-	-	-	-
Veh in Median Storage, #	-	0	-	-	0	-	-	0	-	-	0	-
Grade, %	-	0	-	-	0	-	-	0	-	-	0	-
Peak Hour Factor	85	85	85	85	85	85	85	85	85	85	85	85
Heavy Vehicles, %	0	2	0	0	2	2	3	5	0	1	7	0
Mvmt Flow	25	211	7	4	148	35	27	89	7	41	22	16

Major/Minor	Major1			Major2			Minor1			Minor2		
Conflicting Flow All	187	0	0	245	0	0	488	487	242	491	473	173
Stage 1	-	-	-	-	-	-	292	292	-	178	178	-
Stage 2	-	-	-	-	-	-	196	195	-	313	295	-
Critical Hdwy	4.1	-	-	4.1	-	-	7.13	6.55	6.2	7.11	6.57	6.2
Critical Hdwy Stg 1	-	-	-	-	-	-	6.13	5.55	-	6.11	5.57	-
Critical Hdwy Stg 2	-	-	-	-	-	-	6.13	5.55	-	6.11	5.57	-
Follow-up Hdwy	2.2	-	-	2.2	-	-	3.527	4.045	3.3	3.509	4.063	3.3
Pot Cap-1 Maneuver	1399	-	-	1333	-	-	488	476	802	490	482	876
Stage 1	-	-	-	-	-	-	714	666	-	826	743	-
Stage 2	-	-	-	-	-	-	803	734	-	700	660	-
Platoon blocked, %	-	-	-	-	-	-	-	-	-	-	-	-
Mov Cap-1 Maneuver	1394	-	-	1299	-	-	440	451	781	403	457	870
Mov Cap-2 Maneuver	-	-	-	-	-	-	440	451	-	403	457	-
Stage 1	-	-	-	-	-	-	682	636	-	806	738	-
Stage 2	-	-	-	-	-	-	759	729	-	584	630	-

Approach	EB			WB			NB			SB		
HCM Control Delay, s	0.8			0.1			15.7			14.2		
HCM LOS							C			B		

Minor Lane/Major Mvmt	NBLn1	EBL	EBT	EBR	WBL	WBT	WBR	SBLn1
Capacity (veh/h)	460	1394	-	-	1299	-	-	471
HCM Lane V/C Ratio	0.269	0.018	-	-	0.003	-	-	0.17
HCM Control Delay (s)	15.7	7.6	0	-	7.8	0	-	14.2
HCM Lane LOS	C	A	A	-	A	A	-	B
HCM 95th %tile Q(veh)	1.1	0.1	-	-	0	-	-	0.6

Intersection												
Int Delay, s/veh	1.5											
Movement	EBL	EBT	EBR	WBL	WBT	WBR	NBL	NBT	NBR	SBL	SBT	SBR
Lane Configurations		↕			↕						↕	
Traffic Vol, veh/h	2	169	49	28	158	9	0	0	0	8	28	1
Future Vol, veh/h	2	169	49	28	158	9	0	0	0	8	28	1
Conflicting Peds, #/hr	10	0	3	3	0	10	0	0	0	7	0	0
Sign Control	Free	Free	Free	Free	Free	Free	Stop	Stop	Stop	Stop	Stop	Stop
RT Channelized	-	-	None	-	-	None	-	-	None	-	-	None
Storage Length	-	-	-	-	-	-	-	-	-	-	-	-
Veh in Median Storage, #	-	0	-	-	0	-	-	0	-	-	0	-
Grade, %	-	0	-	-	0	-	-	0	-	-	0	-
Peak Hour Factor	98	98	98	98	98	98	98	98	98	98	98	98
Heavy Vehicles, %	0	2	4	11	2	0	0	2	2	6	0	0
Mvmt Flow	2	172	50	29	161	9	0	0	0	8	29	1

Major/Minor	Major1			Major2			Minor2			
Conflicting Flow All	180	0	0	225	0	0		442	463	176
Stage 1	-	-	-	-	-	-		234	234	-
Stage 2	-	-	-	-	-	-		208	229	-
Critical Hdwy	4.1	-	-	4.21	-	-		6.46	6.5	6.2
Critical Hdwy Stg 1	-	-	-	-	-	-		5.46	5.5	-
Critical Hdwy Stg 2	-	-	-	-	-	-		5.46	5.5	-
Follow-up Hdwy	2.2	-	-	2.299	-	-		3.554	4	3.3
Pot Cap-1 Maneuver	1408	-	-	1292	-	-		566	499	872
Stage 1	-	-	-	-	-	-		796	715	-
Stage 2	-	-	-	-	-	-		817	718	-
Platoon blocked, %		-	-	-	-	-				
Mov Cap-1 Maneuver	1395	-	-	1292	-	-		540	0	864
Mov Cap-2 Maneuver	-	-	-	-	-	-		540	0	-
Stage 1	-	-	-	-	-	-		786	0	-
Stage 2	-	-	-	-	-	-		789	0	-

Approach	EB		WB		SB	
HCM Control Delay, s	0.1		1.1		11.9	
HCM LOS					B	

Minor Lane/Major Mvmt	EBL	EBT	EBR	WBL	WBT	WBR	SBLn1
Capacity (veh/h)	1395	-	-	1292	-	-	563
HCM Lane V/C Ratio	0.001	-	-	0.022	-	-	0.067
HCM Control Delay (s)	7.6	0	-	7.8	0	-	11.9
HCM Lane LOS	A	A	-	A	A	-	B
HCM 95th %tile Q(veh)	0	-	-	0.1	-	-	0.2

Intersection						
Int Delay, s/veh	1.2					
Movement	EBL	EBT	WBT	WBR	SBL	SBR
Lane Configurations		↕	↕		↕	
Traffic Vol, veh/h	7	58	66	99	22	3
Future Vol, veh/h	7	58	66	99	22	3
Conflicting Peds, #/hr	9	0	0	9	0	0
Sign Control	Free	Free	Free	Free	Stop	Stop
RT Channelized	-	None	-	None	-	None
Storage Length	-	-	-	-	0	-
Veh in Median Storage, #	-	0	0	-	0	-
Grade, %	-	0	0	-	0	-
Peak Hour Factor	72	72	72	72	72	72
Heavy Vehicles, %	13	5	0	4	6	0
Mvmt Flow	10	81	92	138	31	4

Major/Minor	Major1	Major2	Minor2		
Conflicting Flow All	239	0	-	0	271
Stage 1	-	-	-	-	170
Stage 2	-	-	-	-	101
Critical Hdwy	4.23	-	-	-	6.46
Critical Hdwy Stg 1	-	-	-	-	5.46
Critical Hdwy Stg 2	-	-	-	-	5.46
Follow-up Hdwy	2.317	-	-	-	3.554
Pot Cap-1 Maneuver	1266	-	-	-	710
Stage 1	-	-	-	-	850
Stage 2	-	-	-	-	913
Platoon blocked, %		-	-	-	
Mov Cap-1 Maneuver	1255	-	-	-	692
Mov Cap-2 Maneuver	-	-	-	-	692
Stage 1	-	-	-	-	836
Stage 2	-	-	-	-	905

Approach	EB	WB	SB
HCM Control Delay, s	0.8	0	10.3
HCM LOS			B

Minor Lane/Major Mvmt	EBL	EBT	WBT	WBR	SBLn1
Capacity (veh/h)	1255	-	-	-	709
HCM Lane V/C Ratio	0.008	-	-	-	0.049
HCM Control Delay (s)	7.9	0	-	-	10.3
HCM Lane LOS	A	A	-	-	B
HCM 95th %tile Q(veh)	0	-	-	-	0.2

Intersection												
Int Delay, s/veh	5.9											
Movement	EBL	EBT	EBR	WBL	WBT	WBR	NBL	NBT	NBR	SBL	SBT	SBR
Lane Configurations		↻			↻			↻			↻	
Traffic Vol, veh/h	0	30	51	31	23	0	136	0	133	2	98	5
Future Vol, veh/h	0	30	51	31	23	0	136	0	133	2	98	5
Conflicting Peds, #/hr	0	0	0	0	0	0	0	0	0	0	0	0
Sign Control	Stop	Stop	Stop	Stop	Stop	Stop	Free	Free	Free	Free	Free	Free
RT Channelized	-	-	None	-	-	None	-	-	None	-	-	None
Storage Length	-	-	-	-	-	-	-	-	-	-	-	-
Veh in Median Storage, #	-	0	-	-	0	-	-	0	-	-	0	-
Grade, %	-	0	-	-	0	-	-	0	-	-	0	-
Peak Hour Factor	84	84	84	84	84	84	84	84	84	84	84	84
Heavy Vehicles, %	0	10	6	3	0	0	2	0	5	0	5	0
Mvmt Flow	0	36	61	37	27	0	162	0	158	2	117	6

Major/Minor	Minor2		Minor1			Major1			Major2			
Conflicting Flow All	-	606	120	576	530	-	123	0	0	158	0	0
Stage 1	-	124	-	403	403	-	-	-	-	-	-	-
Stage 2	-	482	-	173	127	-	-	-	-	-	-	-
Critical Hdwy	-	6.6	6.26	7.13	6.5	-	4.12	-	-	4.1	-	-
Critical Hdwy Stg 1	-	5.6	-	6.13	5.5	-	-	-	-	-	-	-
Critical Hdwy Stg 2	-	5.6	-	6.13	5.5	-	-	-	-	-	-	-
Follow-up Hdwy	-	4.09	3.354	3.527	4	-	2.218	-	-	2.2	-	-
Pot Cap-1 Maneuver	0	401	921	427	457	0	1464	-	-	1434	-	-
Stage 1	0	778	-	622	603	0	-	-	-	-	-	-
Stage 2	0	540	-	827	795	0	-	-	-	-	-	-
Platoon blocked, %								-	-	-	-	-
Mov Cap-1 Maneuver	-	351	921	333	400	-	1464	-	-	1434	-	-
Mov Cap-2 Maneuver	-	351	-	333	400	-	-	-	-	-	-	-
Stage 1	-	777	-	545	528	-	-	-	-	-	-	-
Stage 2	-	473	-	736	794	-	-	-	-	-	-	-

Approach	EB		WB		NB		SB	
HCM Control Delay, s	12.5		17.2		3.9		0.1	
HCM LOS	B		C					

Minor Lane/Major Mvmt	NBL	NBT	NBR	EBLn1WBLn1	SBL	SBT	SBR
Capacity (veh/h)	1464	-	-	575	359	1434	-
HCM Lane V/C Ratio	0.111	-	-	0.168	0.179	0.002	-
HCM Control Delay (s)	7.8	0	-	12.5	17.2	7.5	0
HCM Lane LOS	A	A	-	B	C	A	A
HCM 95th %tile Q(veh)	0.4	-	-	0.6	0.6	0	-

Intersection						
Int Delay, s/veh	0					
Movement	EBL	EBR	NBL	NBT	SBT	SBR
Lane Configurations	T			T		T
Traffic Vol, veh/h	0	0	0	105	27	1
Future Vol, veh/h	0	0	0	105	27	1
Conflicting Peds, #/hr	0	0	0	0	0	0
Sign Control	Stop	Stop	Free	Free	Free	Free
RT Channelized	-	None	-	None	-	None
Storage Length	0	-	-	-	-	-
Veh in Median Storage, #	0	-	-	0	0	-
Grade, %	0	-	-	0	0	-
Peak Hour Factor	84	84	84	84	84	84
Heavy Vehicles, %	0	0	0	4	0	0
Mvmt Flow	0	0	0	125	32	1

Major/Minor	Minor2	Major1		Major2	
Conflicting Flow All	158	33	33	0	0
Stage 1	33	-	-	-	-
Stage 2	125	-	-	-	-
Critical Hdwy	6.4	6.2	4.1	-	-
Critical Hdwy Stg 1	5.4	-	-	-	-
Critical Hdwy Stg 2	5.4	-	-	-	-
Follow-up Hdwy	3.5	3.3	2.2	-	-
Pot Cap-1 Maneuver	838	1046	1592	-	-
Stage 1	995	-	-	-	-
Stage 2	906	-	-	-	-
Platoon blocked, %				-	-
Mov Cap-1 Maneuver	838	1046	1592	-	-
Mov Cap-2 Maneuver	838	-	-	-	-
Stage 1	995	-	-	-	-
Stage 2	906	-	-	-	-

Approach	EB	NB	SB
HCM Control Delay, s	0	0	0
HCM LOS	A		

Minor Lane/Major Mvmt	NBL	NBT	EBLn1	SBT	SBR
Capacity (veh/h)	1592	-	-	-	-
HCM Lane V/C Ratio	-	-	-	-	-
HCM Control Delay (s)	0	-	0	-	-
HCM Lane LOS	A	-	A	-	-
HCM 95th %tile Q(veh)	0	-	-	-	-

Intersection						
Int Delay, s/veh	0					
Movement	EBL	EBR	NBL	NBT	SBT	SBR
Lane Configurations	T			T		T
Traffic Vol, veh/h	0	0	0	105	26	1
Future Vol, veh/h	0	0	0	105	26	1
Conflicting Peds, #/hr	0	0	0	0	0	0
Sign Control	Stop	Stop	Free	Free	Free	Free
RT Channelized	-	None	-	None	-	None
Storage Length	0	-	-	-	-	-
Veh in Median Storage, #	0	-	-	0	0	-
Grade, %	0	-	-	0	0	-
Peak Hour Factor	84	84	84	84	84	84
Heavy Vehicles, %	0	0	0	4	0	0
Mvmt Flow	0	0	0	125	31	1

Major/Minor	Minor2	Major1		Major2	
Conflicting Flow All	157	32	32	0	0
Stage 1	32	-	-	-	-
Stage 2	125	-	-	-	-
Critical Hdwy	6.4	6.2	4.1	-	-
Critical Hdwy Stg 1	5.4	-	-	-	-
Critical Hdwy Stg 2	5.4	-	-	-	-
Follow-up Hdwy	3.5	3.3	2.2	-	-
Pot Cap-1 Maneuver	839	1048	1593	-	-
Stage 1	996	-	-	-	-
Stage 2	906	-	-	-	-
Platoon blocked, %				-	-
Mov Cap-1 Maneuver	839	1048	1593	-	-
Mov Cap-2 Maneuver	839	-	-	-	-
Stage 1	996	-	-	-	-
Stage 2	906	-	-	-	-

Approach	EB	NB	SB
HCM Control Delay, s	0	0	0
HCM LOS	A		

Minor Lane/Major Mvmt	NBL	NBT	EBLn1	SBT	SBR
Capacity (veh/h)	1593	-	-	-	-
HCM Lane V/C Ratio	-	-	-	-	-
HCM Control Delay (s)	0	-	0	-	-
HCM Lane LOS	A	-	A	-	-
HCM 95th %tile Q(veh)	0	-	-	-	-



Intersection						
Int Delay, s/veh	0.2					
Movement	EBL	EBR	NBL	NBT	SBT	SBR
Lane Configurations	T			T		T
Traffic Vol, veh/h	1	1	1	104	24	2
Future Vol, veh/h	1	1	1	104	24	2
Conflicting Peds, #/hr	0	0	0	0	0	0
Sign Control	Stop	Stop	Free	Free	Free	Free
RT Channelized	-	None	-	None	-	None
Storage Length	0	-	-	-	-	-
Veh in Median Storage, #	0	-	-	0	0	-
Grade, %	0	-	-	0	0	-
Peak Hour Factor	84	84	84	84	84	84
Heavy Vehicles, %	0	0	0	4	0	0
Mvmt Flow	1	1	1	124	29	2

Major/Minor	Minor2	Major1		Major2	
Conflicting Flow All	156	30	31	0	0
Stage 1	30	-	-	-	-
Stage 2	126	-	-	-	-
Critical Hdwy	6.4	6.2	4.1	-	-
Critical Hdwy Stg 1	5.4	-	-	-	-
Critical Hdwy Stg 2	5.4	-	-	-	-
Follow-up Hdwy	3.5	3.3	2.2	-	-
Pot Cap-1 Maneuver	840	1050	1595	-	-
Stage 1	998	-	-	-	-
Stage 2	905	-	-	-	-
Platoon blocked, %				-	-
Mov Cap-1 Maneuver	839	1050	1595	-	-
Mov Cap-2 Maneuver	839	-	-	-	-
Stage 1	997	-	-	-	-
Stage 2	905	-	-	-	-

Approach	EB	NB	SB
HCM Control Delay, s	8.9	0.1	0
HCM LOS	A		

Minor Lane/Major Mvmt	NBL	NBT	EBLn1	SBT	SBR
Capacity (veh/h)	1595	-	933	-	-
HCM Lane V/C Ratio	0.001	-	0.003	-	-
HCM Control Delay (s)	7.3	0	8.9	-	-
HCM Lane LOS	A	A	A	-	-
HCM 95th %tile Q(veh)	0	-	0	-	-

Intersection						
Int Delay, s/veh	0					
Movement	EBL	EBT	WBT	WBR	SBL	SBR
Lane Configurations		↕	↕		↕	
Traffic Vol, veh/h	1	65	69	0	0	0
Future Vol, veh/h	1	65	69	0	0	0
Conflicting Peds, #/hr	0	0	0	0	0	0
Sign Control	Free	Free	Free	Free	Stop	Stop
RT Channelized	-	None	-	None	-	None
Storage Length	-	-	-	-	0	-
Veh in Median Storage, #	-	0	0	-	0	-
Grade, %	-	0	0	-	0	-
Peak Hour Factor	84	84	84	84	84	84
Heavy Vehicles, %	0	6	0	0	0	0
Mvmt Flow	1	77	82	0	0	0

Major/Minor	Major1	Major2	Minor2		
Conflicting Flow All	82	0	-	0	161 82
Stage 1	-	-	-	-	82 -
Stage 2	-	-	-	-	79 -
Critical Hdwy	4.1	-	-	-	6.4 6.2
Critical Hdwy Stg 1	-	-	-	-	5.4 -
Critical Hdwy Stg 2	-	-	-	-	5.4 -
Follow-up Hdwy	2.2	-	-	-	3.5 3.3
Pot Cap-1 Maneuver	1528	-	-	-	835 983
Stage 1	-	-	-	-	946 -
Stage 2	-	-	-	-	949 -
Platoon blocked, %		-	-	-	
Mov Cap-1 Maneuver	1528	-	-	-	834 983
Mov Cap-2 Maneuver	-	-	-	-	834 -
Stage 1	-	-	-	-	945 -
Stage 2	-	-	-	-	949 -

Approach	EB	WB	SB
HCM Control Delay, s	0.1	0	0
HCM LOS			A

Minor Lane/Major Mvmt	EBL	EBT	WBT	WBR	SBLn1
Capacity (veh/h)	1528	-	-	-	-
HCM Lane V/C Ratio	0.001	-	-	-	-
HCM Control Delay (s)	7.4	0	-	-	0
HCM Lane LOS	A	A	-	-	A
HCM 95th %tile Q(veh)	0	-	-	-	-

Intersection						
Int Delay, s/veh	0					
Movement	EBL	EBT	WBT	WBR	SBL	SBR
Lane Configurations		↕	↕		↕	
Traffic Vol, veh/h	1	66	69	0	0	0
Future Vol, veh/h	1	66	69	0	0	0
Conflicting Peds, #/hr	0	0	0	0	0	0
Sign Control	Free	Free	Free	Free	Stop	Stop
RT Channelized	-	None	-	None	-	None
Storage Length	-	-	-	-	0	-
Veh in Median Storage, #	-	0	0	-	0	-
Grade, %	-	0	0	-	0	-
Peak Hour Factor	84	84	84	84	84	84
Heavy Vehicles, %	0	6	0	0	0	0
Mvmt Flow	1	79	82	0	0	0

Major/Minor	Major1	Major2	Minor2		
Conflicting Flow All	82	0	-	0	163 82
Stage 1	-	-	-	-	82 -
Stage 2	-	-	-	-	81 -
Critical Hdwy	4.1	-	-	-	6.4 6.2
Critical Hdwy Stg 1	-	-	-	-	5.4 -
Critical Hdwy Stg 2	-	-	-	-	5.4 -
Follow-up Hdwy	2.2	-	-	-	3.5 3.3
Pot Cap-1 Maneuver	1528	-	-	-	832 983
Stage 1	-	-	-	-	946 -
Stage 2	-	-	-	-	947 -
Platoon blocked, %		-	-	-	
Mov Cap-1 Maneuver	1528	-	-	-	831 983
Mov Cap-2 Maneuver	-	-	-	-	831 -
Stage 1	-	-	-	-	945 -
Stage 2	-	-	-	-	947 -

Approach	EB	WB	SB
HCM Control Delay, s	0.1	0	0
HCM LOS			A

Minor Lane/Major Mvmt	EBL	EBT	WBT	WBR	SBLn1
Capacity (veh/h)	1528	-	-	-	-
HCM Lane V/C Ratio	0.001	-	-	-	-
HCM Control Delay (s)	7.4	0	-	-	0
HCM Lane LOS	A	A	-	-	A
HCM 95th %tile Q(veh)	0	-	-	-	-

Intersection												
Int Delay, s/veh	3.2											
Movement	EBL	EBT	EBR	WBL	WBT	WBR	NBL	NBT	NBR	SBL	SBT	SBR
Lane Configurations		↕			↕			↕			↕	
Traffic Vol, veh/h	19	188	6	6	153	20	26	24	6	30	8	13
Future Vol, veh/h	19	188	6	6	153	20	26	24	6	30	8	13
Conflicting Peds, #/hr	2	0	4	4	0	2	2	0	1	1	0	2
Sign Control	Free	Free	Free	Free	Free	Free	Stop	Stop	Stop	Stop	Stop	Stop
RT Channelized	-	-	None	-	-	None	-	-	None	-	-	None
Storage Length	-	-	-	-	-	-	-	-	-	-	-	-
Veh in Median Storage, #	-	0	-	-	0	-	-	0	-	-	0	-
Grade, %	-	0	-	-	0	-	-	0	-	-	0	-
Peak Hour Factor	90	90	90	90	90	90	90	90	90	90	90	90
Heavy Vehicles, %	6	2	0	0	4	0	4	0	0	0	0	8
Mvmt Flow	21	209	7	7	170	22	29	27	7	33	9	14

Major/Minor	Major1			Major2			Minor1			Minor2		
Conflicting Flow All	194	0	0	220	0	0	468	467	218	470	459	185
Stage 1	-	-	-	-	-	-	259	259	-	197	197	-
Stage 2	-	-	-	-	-	-	209	208	-	273	262	-
Critical Hdwy	4.16	-	-	4.1	-	-	7.14	6.5	6.2	7.1	6.5	6.28
Critical Hdwy Stg 1	-	-	-	-	-	-	6.14	5.5	-	6.1	5.5	-
Critical Hdwy Stg 2	-	-	-	-	-	-	6.14	5.5	-	6.1	5.5	-
Follow-up Hdwy	2.254	-	-	2.2	-	-	3.536	4	3.3	3.5	4	3.372
Pot Cap-1 Maneuver	1355	-	-	1361	-	-	502	496	827	507	502	842
Stage 1	-	-	-	-	-	-	741	697	-	809	742	-
Stage 2	-	-	-	-	-	-	788	734	-	737	695	-
Platoon blocked, %	-	-	-	-	-	-	-	-	-	-	-	-
Mov Cap-1 Maneuver	1352	-	-	1356	-	-	475	481	823	472	487	839
Mov Cap-2 Maneuver	-	-	-	-	-	-	475	481	-	472	487	-
Stage 1	-	-	-	-	-	-	725	682	-	793	736	-
Stage 2	-	-	-	-	-	-	759	728	-	689	680	-

Approach	EB			WB			NB			SB		
HCM Control Delay, s	0.7			0.3			13.2			12.5		
HCM LOS							B			B		

Minor Lane/Major Mvmt	NBLn1	EBL	EBT	EBR	WBL	WBT	WBR	SBLn1
Capacity (veh/h)	500	1352	-	-	1356	-	-	534
HCM Lane V/C Ratio	0.124	0.016	-	-	0.005	-	-	0.106
HCM Control Delay (s)	13.2	7.7	0	-	7.7	0	-	12.5
HCM Lane LOS	B	A	A	-	A	A	-	B
HCM 95th %tile Q(veh)	0.4	0	-	-	0	-	-	0.4

Intersection						
Int Delay, s/veh	1.3					
Movement	EBL	EBT	WBT	WBR	SBL	SBR
Lane Configurations		↶	↷		↶	↷
Traffic Vol, veh/h	7	46	40	49	13	4
Future Vol, veh/h	7	46	40	49	13	4
Conflicting Peds, #/hr	4	0	0	0	0	0
Sign Control	Free	Free	Free	Free	Stop	Stop
RT Channelized	-	None	-	None	-	None
Storage Length	-	-	-	-	0	-
Veh in Median Storage, #	-	0	0	-	0	-
Grade, %	-	0	0	-	0	-
Peak Hour Factor	89	89	89	89	89	89
Heavy Vehicles, %	0	2	4	1	0	0
Mvmt Flow	8	52	45	55	15	4

Major/Minor	Major1	Major2	Minor2		
Conflicting Flow All	104	0	-	0	145 77
Stage 1	-	-	-	-	77 -
Stage 2	-	-	-	-	68 -
Critical Hdwy	4.1	-	-	-	6.4 6.2
Critical Hdwy Stg 1	-	-	-	-	5.4 -
Critical Hdwy Stg 2	-	-	-	-	5.4 -
Follow-up Hdwy	2.2	-	-	-	3.5 3.3
Pot Cap-1 Maneuver	1500	-	-	-	852 990
Stage 1	-	-	-	-	951 -
Stage 2	-	-	-	-	960 -
Platoon blocked, %		-	-	-	
Mov Cap-1 Maneuver	1494	-	-	-	840 986
Mov Cap-2 Maneuver	-	-	-	-	840 -
Stage 1	-	-	-	-	941 -
Stage 2	-	-	-	-	956 -

Approach	EB	WB	SB
HCM Control Delay, s	1	0	9.2
HCM LOS			A

Minor Lane/Major Mvmt	EBL	EBT	WBT	WBR	SBLn1
Capacity (veh/h)	1494	-	-	-	870
HCM Lane V/C Ratio	0.005	-	-	-	0.022
HCM Control Delay (s)	7.4	0	-	-	9.2
HCM Lane LOS	A	A	-	-	A
HCM 95th %tile Q(veh)	0	-	-	-	0.1

Intersection						
Int Delay, s/veh	0					
Movement	EBL	EBR	NBL	NBT	SBT	SBR
Lane Configurations	T			T		T
Traffic Vol, veh/h	0	0	0	57	19	1
Future Vol, veh/h	0	0	0	57	19	1
Conflicting Peds, #/hr	0	0	0	0	0	0
Sign Control	Stop	Stop	Free	Free	Free	Free
RT Channelized	-	None	-	None	-	None
Storage Length	0	-	-	-	-	-
Veh in Median Storage, #	0	-	-	0	0	-
Grade, %	0	-	-	0	0	-
Peak Hour Factor	89	89	89	89	89	89
Heavy Vehicles, %	0	0	0	1	0	0
Mvmt Flow	0	0	0	64	21	1

Major/Minor	Minor2	Major1		Major2	
Conflicting Flow All	86	22	22	0	0
Stage 1	22	-	-	-	-
Stage 2	64	-	-	-	-
Critical Hdwy	6.4	6.2	4.1	-	-
Critical Hdwy Stg 1	5.4	-	-	-	-
Critical Hdwy Stg 2	5.4	-	-	-	-
Follow-up Hdwy	3.5	3.3	2.2	-	-
Pot Cap-1 Maneuver	920	1061	1607	-	-
Stage 1	1006	-	-	-	-
Stage 2	964	-	-	-	-
Platoon blocked, %				-	-
Mov Cap-1 Maneuver	920	1061	1607	-	-
Mov Cap-2 Maneuver	920	-	-	-	-
Stage 1	1006	-	-	-	-
Stage 2	964	-	-	-	-

Approach	EB	NB	SB
HCM Control Delay, s	0	0	0
HCM LOS	A		

Minor Lane/Major Mvmt	NBL	NBT	EBLn1	SBT	SBR
Capacity (veh/h)	1607	-	-	-	-
HCM Lane V/C Ratio	-	-	-	-	-
HCM Control Delay (s)	0	-	0	-	-
HCM Lane LOS	A	-	A	-	-
HCM 95th %tile Q(veh)	0	-	-	-	-

Intersection						
Int Delay, s/veh	0					
Movement	EBL	EBR	NBL	NBT	SBT	SBR
Lane Configurations	T			T		T
Traffic Vol, veh/h	0	0	0	57	18	1
Future Vol, veh/h	0	0	0	57	18	1
Conflicting Peds, #/hr	0	0	0	0	0	0
Sign Control	Stop	Stop	Free	Free	Free	Free
RT Channelized	-	None	-	None	-	None
Storage Length	0	-	-	-	-	-
Veh in Median Storage, #	0	-	-	0	0	-
Grade, %	0	-	-	0	0	-
Peak Hour Factor	89	89	89	89	89	89
Heavy Vehicles, %	0	2	2	2	2	2
Mvmt Flow	0	0	0	64	20	1

Major/Minor	Minor2	Major1		Major2	
Conflicting Flow All	85	21	21	0	0
Stage 1	21	-	-	-	-
Stage 2	64	-	-	-	-
Critical Hdwy	6.4	6.22	4.12	-	-
Critical Hdwy Stg 1	5.4	-	-	-	-
Critical Hdwy Stg 2	5.4	-	-	-	-
Follow-up Hdwy	3.5	3.318	2.218	-	-
Pot Cap-1 Maneuver	921	1056	1595	-	-
Stage 1	1007	-	-	-	-
Stage 2	964	-	-	-	-
Platoon blocked, %				-	-
Mov Cap-1 Maneuver	921	1056	1595	-	-
Mov Cap-2 Maneuver	921	-	-	-	-
Stage 1	1007	-	-	-	-
Stage 2	964	-	-	-	-

Approach	EB	NB	SB
HCM Control Delay, s	0	0	0
HCM LOS	A		

Minor Lane/Major Mvmt	NBL	NBT	EBLn1	SBT	SBR
Capacity (veh/h)	1595	-	-	-	-
HCM Lane V/C Ratio	-	-	-	-	-
HCM Control Delay (s)	0	-	0	-	-
HCM Lane LOS	A	-	A	-	-
HCM 95th %tile Q(veh)	0	-	-	-	-

Intersection						
Int Delay, s/veh	0.3					
Movement	EBL	EBR	NBL	NBT	SBT	SBR
Lane Configurations	T			T		T
Traffic Vol, veh/h	1	1	1	56	16	2
Future Vol, veh/h	1	1	1	56	16	2
Conflicting Peds, #/hr	0	0	0	0	0	0
Sign Control	Stop	Stop	Free	Free	Free	Free
RT Channelized	-	None	-	None	-	None
Storage Length	0	-	-	-	-	-
Veh in Median Storage, #	0	-	-	0	0	-
Grade, %	0	-	-	0	0	-
Peak Hour Factor	89	89	89	89	89	89
Heavy Vehicles, %	0	0	0	1	0	0
Mvmt Flow	1	1	1	63	18	2

Major/Minor	Minor2	Major1		Major2	
Conflicting Flow All	84	19	20	0	0
Stage 1	19	-	-	-	-
Stage 2	65	-	-	-	-
Critical Hdwy	6.4	6.2	4.1	-	-
Critical Hdwy Stg 1	5.4	-	-	-	-
Critical Hdwy Stg 2	5.4	-	-	-	-
Follow-up Hdwy	3.5	3.3	2.2	-	-
Pot Cap-1 Maneuver	923	1065	1609	-	-
Stage 1	1009	-	-	-	-
Stage 2	963	-	-	-	-
Platoon blocked, %				-	-
Mov Cap-1 Maneuver	922	1065	1609	-	-
Mov Cap-2 Maneuver	922	-	-	-	-
Stage 1	1008	-	-	-	-
Stage 2	963	-	-	-	-

Approach	EB	NB	SB
HCM Control Delay, s	8.7	0.1	0
HCM LOS	A		

Minor Lane/Major Mvmt	NBL	NBT	EBLn1	SBT	SBR
Capacity (veh/h)	1609	-	988	-	-
HCM Lane V/C Ratio	0.001	-	0.002	-	-
HCM Control Delay (s)	7.2	0	8.7	-	-
HCM Lane LOS	A	A	A	-	-
HCM 95th %tile Q(veh)	0	-	0	-	-



Intersection						
Int Delay, s/veh	0.1					
Movement	EBL	EBT	WBT	WBR	SBL	SBR
Lane Configurations		↕	↕		↕	
Traffic Vol, veh/h	1	53	44	0	0	0
Future Vol, veh/h	1	53	44	0	0	0
Conflicting Peds, #/hr	0	0	0	0	0	0
Sign Control	Free	Free	Free	Free	Stop	Stop
RT Channelized	-	None	-	None	-	None
Storage Length	-	-	-	-	0	-
Veh in Median Storage, #	-	0	0	-	0	-
Grade, %	-	0	0	-	0	-
Peak Hour Factor	89	89	89	89	89	89
Heavy Vehicles, %	0	1	4	0	0	0
Mvmt Flow	1	60	49	0	0	0

Major/Minor	Major1	Major2	Minor2		
Conflicting Flow All	49	0	-	0	111 49
Stage 1	-	-	-	-	49 -
Stage 2	-	-	-	-	62 -
Critical Hdwy	4.1	-	-	-	6.4 6.2
Critical Hdwy Stg 1	-	-	-	-	5.4 -
Critical Hdwy Stg 2	-	-	-	-	5.4 -
Follow-up Hdwy	2.2	-	-	-	3.5 3.3
Pot Cap-1 Maneuver	1571	-	-	-	891 1025
Stage 1	-	-	-	-	979 -
Stage 2	-	-	-	-	966 -
Platoon blocked, %		-	-	-	
Mov Cap-1 Maneuver	1571	-	-	-	890 1025
Mov Cap-2 Maneuver	-	-	-	-	890 -
Stage 1	-	-	-	-	978 -
Stage 2	-	-	-	-	966 -

Approach	EB	WB	SB
HCM Control Delay, s	0.1	0	0
HCM LOS			A

Minor Lane/Major Mvmt	EBL	EBT	WBT	WBR	SBLn1
Capacity (veh/h)	1571	-	-	-	-
HCM Lane V/C Ratio	0.001	-	-	-	-
HCM Control Delay (s)	7.3	0	-	-	0
HCM Lane LOS	A	A	-	-	A
HCM 95th %tile Q(veh)	0	-	-	-	-

Intersection						
Int Delay, s/veh	0.1					
Movement	EBL	EBT	WBT	WBR	SBL	SBR
Lane Configurations		↕	↕		↕	
Traffic Vol, veh/h	1	54	44	0	0	0
Future Vol, veh/h	1	54	44	0	0	0
Conflicting Peds, #/hr	0	0	0	0	0	0
Sign Control	Free	Free	Free	Free	Stop	Stop
RT Channelized	-	None	-	None	-	None
Storage Length	-	-	-	-	0	-
Veh in Median Storage, #	-	0	0	-	0	-
Grade, %	-	0	0	-	0	-
Peak Hour Factor	89	89	89	89	89	89
Heavy Vehicles, %	0	1	4	0	2	2
Mvmt Flow	1	61	49	0	0	0

Major/Minor	Major1	Major2	Minor2		
Conflicting Flow All	49	0	-	0	112 49
Stage 1	-	-	-	-	49 -
Stage 2	-	-	-	-	63 -
Critical Hdwy	4.1	-	-	-	6.42 6.22
Critical Hdwy Stg 1	-	-	-	-	5.42 -
Critical Hdwy Stg 2	-	-	-	-	5.42 -
Follow-up Hdwy	2.2	-	-	-	3.518 3.318
Pot Cap-1 Maneuver	1571	-	-	-	885 1020
Stage 1	-	-	-	-	973 -
Stage 2	-	-	-	-	960 -
Platoon blocked, %		-	-	-	
Mov Cap-1 Maneuver	1571	-	-	-	884 1020
Mov Cap-2 Maneuver	-	-	-	-	884 -
Stage 1	-	-	-	-	972 -
Stage 2	-	-	-	-	960 -

Approach	EB	WB	SB
HCM Control Delay, s	0.1	0	0
HCM LOS			A

Minor Lane/Major Mvmt	EBL	EBT	WBT	WBR	SBLn1
Capacity (veh/h)	1571	-	-	-	-
HCM Lane V/C Ratio	0.001	-	-	-	-
HCM Control Delay (s)	7.3	0	-	-	0
HCM Lane LOS	A	A	-	-	A
HCM 95th %tile Q(veh)	0	-	-	-	-

Intersection												
Int Delay, s/veh	2.6											
Movement	EBL	EBT	EBR	WBL	WBT	WBR	NBL	NBT	NBR	SBL	SBT	SBR
Lane Configurations		↕			↕			↕			↕	
Traffic Vol, veh/h	8	153	5	3	157	12	13	20	2	23	12	16
Future Vol, veh/h	8	153	5	3	157	12	13	20	2	23	12	16
Conflicting Peds, #/hr	4	0	27	27	0	4	3	0	0	0	0	3
Sign Control	Free	Free	Free	Free	Free	Free	Stop	Stop	Stop	Stop	Stop	Stop
RT Channelized	-	-	None	-	-	None	-	-	None	-	-	None
Storage Length	-	-	-	-	-	-	-	-	-	-	-	-
Veh in Median Storage, #	-	0	-	-	0	-	-	0	-	-	0	-
Grade, %	-	0	-	-	0	-	-	0	-	-	0	-
Peak Hour Factor	92	92	92	92	92	92	92	92	92	92	92	92
Heavy Vehicles, %	0	3	50	0	4	0	0	0	0	0	0	0
Mvmt Flow	9	166	5	3	171	13	14	22	2	25	13	17

Major/Minor	Major1			Major2			Minor1			Minor2		
Conflicting Flow All	188	0	0	198	0	0	416	408	196	387	404	185
Stage 1	-	-	-	-	-	-	214	214	-	188	188	-
Stage 2	-	-	-	-	-	-	202	194	-	199	216	-
Critical Hdwy	4.1	-	-	4.1	-	-	7.1	6.5	6.2	7.1	6.5	6.2
Critical Hdwy Stg 1	-	-	-	-	-	-	6.1	5.5	-	6.1	5.5	-
Critical Hdwy Stg 2	-	-	-	-	-	-	6.1	5.5	-	6.1	5.5	-
Follow-up Hdwy	2.2	-	-	2.2	-	-	3.5	4	3.3	3.5	4	3.3
Pot Cap-1 Maneuver	1398	-	-	1387	-	-	551	536	850	575	539	862
Stage 1	-	-	-	-	-	-	793	729	-	818	748	-
Stage 2	-	-	-	-	-	-	805	744	-	807	728	-
Platoon blocked, %		-	-		-	-						
Mov Cap-1 Maneuver	1393	-	-	1351	-	-	511	515	828	549	518	856
Mov Cap-2 Maneuver	-	-	-	-	-	-	511	515	-	549	518	-
Stage 1	-	-	-	-	-	-	767	705	-	809	744	-
Stage 2	-	-	-	-	-	-	771	740	-	775	704	-

Approach	EB			WB			NB			SB		
HCM Control Delay, s	0.4			0.1			12.4			11.5		
HCM LOS							B			B		

Minor Lane/Major Mvmt	NBLn1	EBL	EBT	EBR	WBL	WBT	WBR	SBLn1
Capacity (veh/h)	525	1393	-	-	1351	-	-	609
HCM Lane V/C Ratio	0.072	0.006	-	-	0.002	-	-	0.091
HCM Control Delay (s)	12.4	7.6	0	-	7.7	0	-	11.5
HCM Lane LOS	B	A	A	-	A	A	-	B
HCM 95th %tile Q(veh)	0.2	0	-	-	0	-	-	0.3

Intersection						
Int Delay, s/veh	1.8					
Movement	EBL	EBT	WBT	WBR	SBL	SBR
Lane Configurations		↶	↷		↶	
Traffic Vol, veh/h	3	31	35	30	18	2
Future Vol, veh/h	3	31	35	30	18	2
Conflicting Peds, #/hr	5	0	0	0	0	0
Sign Control	Free	Free	Free	Free	Stop	Stop
RT Channelized	-	None	-	None	-	None
Storage Length	-	-	-	-	0	-
Veh in Median Storage, #	-	0	0	-	0	-
Grade, %	-	0	0	-	0	-
Peak Hour Factor	71	71	71	71	71	71
Heavy Vehicles, %	0	2	1	1	4	0
Mvmt Flow	4	44	49	42	25	3

Major/Minor	Major1	Major2	Minor2		
Conflicting Flow All	96	0	-	0	127 75
Stage 1	-	-	-	-	75 -
Stage 2	-	-	-	-	52 -
Critical Hdwy	4.1	-	-	-	6.44 6.2
Critical Hdwy Stg 1	-	-	-	-	5.44 -
Critical Hdwy Stg 2	-	-	-	-	5.44 -
Follow-up Hdwy	2.2	-	-	-	3.536 3.3
Pot Cap-1 Maneuver	1510	-	-	-	863 992
Stage 1	-	-	-	-	943 -
Stage 2	-	-	-	-	965 -
Platoon blocked, %		-	-	-	
Mov Cap-1 Maneuver	1503	-	-	-	852 987
Mov Cap-2 Maneuver	-	-	-	-	852 -
Stage 1	-	-	-	-	935 -
Stage 2	-	-	-	-	960 -

Approach	EB	WB	SB
HCM Control Delay, s	0.7	0	9.3
HCM LOS			A

Minor Lane/Major Mvmt	EBL	EBT	WBT	WBR	SBLn1
Capacity (veh/h)	1503	-	-	-	864
HCM Lane V/C Ratio	0.003	-	-	-	0.033
HCM Control Delay (s)	7.4	0	-	-	9.3
HCM Lane LOS	A	A	-	-	A
HCM 95th %tile Q(veh)	0	-	-	-	0.1

Intersection						
Int Delay, s/veh	0.2					
Movement	EBL	EBR	NBL	NBT	SBT	SBR
Lane Configurations						
Traffic Vol, veh/h	1	0	0	34	20	0
Future Vol, veh/h	1	0	0	34	20	0
Conflicting Peds, #/hr	0	0	0	0	0	0
Sign Control	Stop	Stop	Free	Free	Free	Free
RT Channelized	-	None	-	None	-	None
Storage Length	0	-	-	-	-	-
Veh in Median Storage, #	0	-	-	0	0	-
Grade, %	0	-	-	0	0	-
Peak Hour Factor	71	71	71	71	71	71
Heavy Vehicles, %	0	0	0	1	0	0
Mvmt Flow	1	0	0	48	28	0

Major/Minor	Minor2	Major1		Major2	
Conflicting Flow All	76	28	28	0	0
Stage 1	28	-	-	-	-
Stage 2	48	-	-	-	-
Critical Hdwy	6.4	6.2	4.1	-	-
Critical Hdwy Stg 1	5.4	-	-	-	-
Critical Hdwy Stg 2	5.4	-	-	-	-
Follow-up Hdwy	3.5	3.3	2.2	-	-
Pot Cap-1 Maneuver	932	1053	1599	-	-
Stage 1	1000	-	-	-	-
Stage 2	980	-	-	-	-
Platoon blocked, %				-	-
Mov Cap-1 Maneuver	932	1053	1599	-	-
Mov Cap-2 Maneuver	932	-	-	-	-
Stage 1	1000	-	-	-	-
Stage 2	980	-	-	-	-

Approach	EB	NB	SB
HCM Control Delay, s	8.9	0	0
HCM LOS	A		

Minor Lane/Major Mvmt	NBL	NBT	EBLn1	SBT	SBR
Capacity (veh/h)	1599	-	932	-	-
HCM Lane V/C Ratio	-	-	0.002	-	-
HCM Control Delay (s)	0	-	8.9	-	-
HCM Lane LOS	A	-	A	-	-
HCM 95th %tile Q(veh)	0	-	0	-	-

Intersection						
Int Delay, s/veh	0.2					
Movement	EBL	EBR	NBL	NBT	SBT	SBR
Lane Configurations	T			T		T
Traffic Vol, veh/h	1	0	0	33	20	0
Future Vol, veh/h	1	0	0	33	20	0
Conflicting Peds, #/hr	0	0	0	0	0	0
Sign Control	Stop	Stop	Free	Free	Free	Free
RT Channelized	-	None	-	None	-	None
Storage Length	0	-	-	-	-	-
Veh in Median Storage, #	0	-	-	0	0	-
Grade, %	0	-	-	0	0	-
Peak Hour Factor	71	71	71	71	71	71
Heavy Vehicles, %	0	1	0	0	0	0
Mvmt Flow	1	0	0	46	28	0

Major/Minor	Minor2	Major1	Major2			
Conflicting Flow All	74	28	28	0	-	0
Stage 1	28	-	-	-	-	-
Stage 2	46	-	-	-	-	-
Critical Hdwy	6.4	6.21	4.1	-	-	-
Critical Hdwy Stg 1	5.4	-	-	-	-	-
Critical Hdwy Stg 2	5.4	-	-	-	-	-
Follow-up Hdwy	3.5	3.309	2.2	-	-	-
Pot Cap-1 Maneuver	935	1050	1599	-	-	-
Stage 1	1000	-	-	-	-	-
Stage 2	982	-	-	-	-	-
Platoon blocked, %				-	-	-
Mov Cap-1 Maneuver	935	1050	1599	-	-	-
Mov Cap-2 Maneuver	935	-	-	-	-	-
Stage 1	1000	-	-	-	-	-
Stage 2	982	-	-	-	-	-

Approach	EB	NB	SB
HCM Control Delay, s	8.9	0	0
HCM LOS	A		

Minor Lane/Major Mvmt	NBL	NBT	EBLn1	SBT	SBR
Capacity (veh/h)	1599	-	935	-	-
HCM Lane V/C Ratio	-	-	0.002	-	-
HCM Control Delay (s)	0	-	8.9	-	-
HCM Lane LOS	A	-	A	-	-
HCM 95th %tile Q(veh)	0	-	0	-	-

Intersection						
Int Delay, s/veh	0.4					
Movement	EBL	EBR	NBL	NBT	SBT	SBR
Lane Configurations	T			T		T
Traffic Vol, veh/h	1	1	1	32	19	1
Future Vol, veh/h	1	1	1	32	19	1
Conflicting Peds, #/hr	0	0	0	0	0	0
Sign Control	Stop	Stop	Free	Free	Free	Free
RT Channelized	-	None	-	None	-	None
Storage Length	0	-	-	-	-	-
Veh in Median Storage, #	0	-	-	0	0	-
Grade, %	0	-	-	0	0	-
Peak Hour Factor	71	71	71	71	71	71
Heavy Vehicles, %	0	0	1	0	0	0
Mvmt Flow	1	1	1	45	27	1

Major/Minor	Minor2	Major1		Major2	
Conflicting Flow All	75	28	28	0	0
Stage 1	28	-	-	-	-
Stage 2	47	-	-	-	-
Critical Hdwy	6.4	6.2	4.11	-	-
Critical Hdwy Stg 1	5.4	-	-	-	-
Critical Hdwy Stg 2	5.4	-	-	-	-
Follow-up Hdwy	3.5	3.3	2.209	-	-
Pot Cap-1 Maneuver	933	1053	1592	-	-
Stage 1	1000	-	-	-	-
Stage 2	981	-	-	-	-
Platoon blocked, %				-	-
Mov Cap-1 Maneuver	932	1053	1592	-	-
Mov Cap-2 Maneuver	932	-	-	-	-
Stage 1	999	-	-	-	-
Stage 2	981	-	-	-	-

Approach	EB	NB	SB
HCM Control Delay, s	8.7	0.2	0
HCM LOS	A		

Minor Lane/Major Mvmt	NBL	NBT	EBLn1	SBT	SBR
Capacity (veh/h)	1592	-	989	-	-
HCM Lane V/C Ratio	0.001	-	0.003	-	-
HCM Control Delay (s)	7.3	0	8.7	-	-
HCM Lane LOS	A	A	A	-	-
HCM 95th %tile Q(veh)	0	-	0	-	-

Intersection						
Int Delay, s/veh	0.1					
Movement	EBL	EBT	WBT	WBR	SBL	SBR
Lane Configurations		↕	↕		↕	
Traffic Vol, veh/h	0	34	37	0	0	1
Future Vol, veh/h	0	34	37	0	0	1
Conflicting Peds, #/hr	0	0	0	0	0	0
Sign Control	Free	Free	Free	Free	Stop	Stop
RT Channelized	-	None	-	None	-	None
Storage Length	-	-	-	-	0	-
Veh in Median Storage, #	-	0	0	-	0	-
Grade, %	-	0	0	-	0	-
Peak Hour Factor	71	71	71	71	71	71
Heavy Vehicles, %	0	1	1	0	0	0
Mvmt Flow	0	48	52	0	0	1

Major/Minor	Major1	Major2	Minor2		
Conflicting Flow All	52	0	-	0	100 52
Stage 1	-	-	-	-	52 -
Stage 2	-	-	-	-	48 -
Critical Hdwy	4.1	-	-	-	6.4 6.2
Critical Hdwy Stg 1	-	-	-	-	5.4 -
Critical Hdwy Stg 2	-	-	-	-	5.4 -
Follow-up Hdwy	2.2	-	-	-	3.5 3.3
Pot Cap-1 Maneuver	1567	-	-	-	904 1021
Stage 1	-	-	-	-	976 -
Stage 2	-	-	-	-	980 -
Platoon blocked, %		-	-	-	
Mov Cap-1 Maneuver	1567	-	-	-	904 1021
Mov Cap-2 Maneuver	-	-	-	-	904 -
Stage 1	-	-	-	-	976 -
Stage 2	-	-	-	-	980 -

Approach	EB	WB	SB
HCM Control Delay, s	0	0	8.5
HCM LOS			A

Minor Lane/Major Mvmt	EBL	EBT	WBT	WBR	SBLn1
Capacity (veh/h)	1567	-	-	-	1021
HCM Lane V/C Ratio	-	-	-	-	0.001
HCM Control Delay (s)	0	-	-	-	8.5
HCM Lane LOS	A	-	-	-	A
HCM 95th %tile Q(veh)	0	-	-	-	0



Intersection						
Int Delay, s/veh	0.1					
Movement	EBL	EBT	WBT	WBR	SBL	SBR
Lane Configurations		↶	↷		↶	
Traffic Vol, veh/h	0	34	38	0	0	1
Future Vol, veh/h	0	34	38	0	0	1
Conflicting Peds, #/hr	0	0	0	0	0	0
Sign Control	Free	Free	Free	Free	Stop	Stop
RT Channelized	-	None	-	None	-	None
Storage Length	-	-	-	-	0	-
Veh in Median Storage, #	-	0	0	-	0	-
Grade, %	-	0	0	-	0	-
Peak Hour Factor	71	71	71	71	71	71
Heavy Vehicles, %	0	1	1	0	0	0
Mvmt Flow	0	48	54	0	0	1

Major/Minor	Major1	Major2	Minor2		
Conflicting Flow All	54	0	-	0	102 54
Stage 1	-	-	-	-	54 -
Stage 2	-	-	-	-	48 -
Critical Hdwy	4.1	-	-	-	6.4 6.2
Critical Hdwy Stg 1	-	-	-	-	5.4 -
Critical Hdwy Stg 2	-	-	-	-	5.4 -
Follow-up Hdwy	2.2	-	-	-	3.5 3.3
Pot Cap-1 Maneuver	1564	-	-	-	901 1019
Stage 1	-	-	-	-	974 -
Stage 2	-	-	-	-	980 -
Platoon blocked, %		-	-	-	
Mov Cap-1 Maneuver	1564	-	-	-	901 1019
Mov Cap-2 Maneuver	-	-	-	-	901 -
Stage 1	-	-	-	-	974 -
Stage 2	-	-	-	-	980 -

Approach	EB	WB	SB
HCM Control Delay, s	0	0	8.5
HCM LOS			A

Minor Lane/Major Mvmt	EBL	EBT	WBT	WBR	SBLn1
Capacity (veh/h)	1564	-	-	-	1019
HCM Lane V/C Ratio	-	-	-	-	0.001
HCM Control Delay (s)	0	-	-	-	8.5
HCM Lane LOS	A	-	-	-	A
HCM 95th %tile Q(veh)	0	-	-	-	0

# Exhibit C



Village of Rhinebeck  
76 East Market Street  
Rhinebeck NY 12572

c/o:

Ms. Brandee Nelson  
Tighe & Bond  
47 West Market Street  
Rhinebeck NY 12572

6 Mulberry Street (the Project)  
Rhinebeck NY 12572  
MEMO: Construction Noise  
Hours of Operation

**Construction Hours:**

Residential Construction shall be allowed between 7 AM and 6 PM on weekdays. Work may take place at other times only if the site has a construction variance/permit from the Village of Rhinebeck.

**Unlawful Noises:**

**Building Construction:**

Operating or permitting the operation of any tool or equipment used in construction drilling or demolition work, including excavation, and the alteration or repair of any building between the hours of 10:00 p.m. and 7:00 a.m., except in the case of an emergency or the interests of public safety.

**Refuse Compacting:**

The operation of a refuse compacting vehicle in the process of compacting or collecting refuse contained in a dumpster or similar receptacle between the hours of 10:00 p.m. and 7:00 a.m. or the operation of a refuse compacting vehicle in the process of compacting or collecting refuse contained in individual garbage cans between the hours of 10:00 p.m. and 7:00 a.m.

**Heavy Equipment:**

The operation of any pile driver, bulldozer, pneumatic hammer, grinder, or other construction equipment which creates unreasonable noise, except between 7:00 a.m. and 6:00 p.m. on weekdays, and between 10:00 a.m. and 6:00 p.m. Saturdays, except as may otherwise be permitted by the Building Inspector in cases of urgent necessity in the interest of public safety. The operation or use of such heavy equipment on Sundays and legal holidays is prohibited.

**Machinery:**

The operation of any machinery, equipment, pump, fan, air-conditioning apparatus, or other mechanical device in such a manner as to create unreasonable noise.

**Loading and Unloading:**

The loading or unloading of any materials, equipment, or the handling of bales, boxes, crates, containers, or similar objects so as to create unreasonable noise.



**Vibration:**

The operating or permitting the operation of any device that creates vibration which is above the vibration perception threshold of an individual beyond the property where the source is located. For the purposes of this section, "vibration perception threshold" means the minimum ground- or structure-borne vibrational motion necessary to cause a normal person to be aware of the vibration by such direct means as, but not limited to, sensation by touch or visual observation of moving objects.

**Presumptive Evidence:**

It shall be prima facie evidence that an act is in violation of this memo when a sound-level meter indicates that the decibel level of a particular activity is in excess of 60 dBA between the hours of 7:00 a.m. and 9:00 p.m. and 50 dBA between the hours of 9:00 p.m. and 7:00 a.m. measured at a distance of 50 feet from the source of the noise. All measurements will be made on the A-weighted sound level of a sound-level meter with a slow response.

**Exempt Sounds:**

Sounds which are authorized as exempt from the above described Unlawful Noises, by resolution of the Village of Rhinebeck Board of Trustees because said noise, although otherwise causing unreasonable noise, would be generated from a non public-works project where the Village of Rhinebeck Board of Trustees, for good cause shown, has determined that such waiver would be protective of the general health, safety and welfare of the citizenry of the Village of Rhinebeck and/or a necessary consequence of executing the approved and permitted Project in a reasonable and efficient manner. However, should noise become a problem, the Village of Rhinebeck Board of Trustees may rescind or modify the waiver.

Respectfully,

David Ruff AIA, RA, NCARB  
NAVA Partners LLC  
Dutchess Shepherd LLC

# Exhibit D



# Exhibit E

**PHASE 1A LITERATURE SEARCH AND SENSITIVITY ASSESSMENT &  
PHASE 1B ARCHAEOLOGICAL FIELD RECONNAISSANCE SURVEY  
DUTCHESS SHEPHERD BULKELEY SCHOOL PROJECT**

6 MULBERRY STREET  
VILLAGE OF RHINEBECK, DUTCHESS COUNTY, NEW YORK

PREPARED FOR:

DUTCHESS SHEPHERD LLC  
265 MARKET LANE  
CLINTON CORNERS, NEW YORK, 12514



PO Box 124  
LAGRANGEVILLE NEW YORK 12540

MARCH 2023



## MANAGEMENT SUMMARY

SHPO Project Review Number (if available):

Involved State and Federal Agencies: SEQR

Phase of Survey: **Phase 1A Literature Search & Sensitivity Assessment & Phase 1B Archaeological Field Reconnaissance Survey**

Location Information:

Location: **6 Mulberry Street**

Minor Civil Division: **Village of Rhinebeck**

County: **Dutchess County**

USGS Quadrangle: **2019 Kingston, East, NY Quadrangle**

Survey Area (Metric & English)

Length: **110' / 33.5 m**

Width: **62' / 18.9 m**

Number of Acres Surveyed: **±1.44 (0.58 hectares)**

Archaeological Survey Overview

Number & Interval of Shovel Tests: **15 completed @ 50' (15 m) intervals**

Number & Size of Units: N/A

Width of Plowed Strips: N/A

Surface Survey Transect Interval: N/A

Results of Archaeological Survey

Number & name of precontact sites identified: **0.**

Number & name of historic sites identified: **0**

Number & name of sites recommended for Phase II/Avoidance: **0.**

Report Author (s): **Franco Zani Jr., Beth Selig, MA, RPA.**

HCS Project Number: **23-02-674**

Date of Report: **March 20, 2023**

# TABLE OF CONTENTS

LIST OF FIGURES

LIST OF TABLES

LIST OF PHOTOGRAPHS

I. PHASE 1A LITERATURE SEARCH AND SENSITIVITY ASSESSMENT .....	1
A. DUTCHESS SHEPHERD BULKELEY SCHOOLHOUSE PROJECT DESCRIPTION.....	1
B. ENVIRONMENTAL CONDITIONS .....	4
• ECOLOGY .....	4
• GEOLOGY .....	4
• DRAINAGE.....	4
• SOILS .....	4
C. RECORDED ARCHAEOLOGICAL SITES AND SURVEYS .....	8
• PREVIOUSLY RECORDED ARCHAEOLOGICAL SITES.....	8
• PREVIOUSLY COMPLETED ARCHAEOLOGICAL SURVEYS .....	9
D. PRECONTACT CONTEXT.....	9
E. HISTORIC CONTEXT .....	10
• HISTORY OF BULKELEY SCHOOL.....	11
• CARTOGRAPHIC RESEARCH.....	13
F. NATIONAL REGISTER ELIGIBLE/LISTED SITES.....	27
G. ASSESSMENT OF SENSITIVITY FOR CULTURAL RESOURCES .....	27
• PRECONTACT SENSITIVITY.....	27
• HISTORIC SENSITIVITY .....	27
H. SUMMARY AND RECOMMENDATIONS.....	27
II. PHASE 1B ARCHAEOLOGICAL FIELD RECONNAISSANCE SURVEY .....	28
I. ARCHAEOLOGICAL SURVEY METHODOLOGY .....	28
J. ARCHAEOLOGICAL SURVEY RESULTS .....	28
K. SUMMARY AND RECOMMENDATIONS.....	29
L. BIBLIOGRAPHY.....	34

APPENDIX A: SHOVEL TEST RECORDS

## LIST OF FIGURES

Figure 1: 2019 USGS Topographical Map. Kingston East, NY Quadrangles. 7.5 Minute Series. (Source: USGS.gov.) Scale: 1"=1,000'.....	2
Figure 2: 2021 Aerial image showing the location of the Project APE (Source: New York GIS Clearinghouse). Scale: 1" =150'.....	3
Figure 3: Aerial Image showing soil units within the Project Parcel. (Source: Natural Resources Conservation Service.) Scale: 1" =150'.....	5
Figure 4: Image of the Bulkeley School House. Circa 1870. ....	12
Figure 5: Image of the Bulkeley School with southern addition. Circa 1908. (Source Morse 1908). ....	12
Figure 6: Post card of the school building c. 1928. (Source: New York Heritage digital collections). ....	13
Figure 7: 1850 J.C. Sidney <i>Atlas of Dutchess County, New York</i> . (Source: Library of Congress) Scale: 1" =1000'.....	14
Figure 8: 1858 J. E. Gillette. Map of Dutchess County, New York. (Source: Library of Congress) Scale: 1" =200'.....	15
Figure 9: 1867 F.W. Beers. <i>Village of Rhinebeck, Atlas of the County of Dutchess, N.Y.</i> (Source: David Rumsey Cartography Associates) Scale: 1"=335'.....	16
Figure 10: 1886 Sanborn Fire Insurance Map. <i>Village of Rhinebeck N.Y.</i> Scale: 1"=112'. (Source: Library of Congress) Scale: 1"=112'.....	17
Figure 11: 1890 L.R. Burleigh. <i>Birds Eye View of the Village of Rhinebeck N.Y.</i> (Source: Library of Congress) Scale: 1"=75'.....	18
Figure 12: 1905 Sanborn Fire Insurance Map. <i>Village of Rhinebeck N.Y.</i> (Source: Library of Congress) Scale: 1"=125'.....	19
Figure 13: 1912 Sanborn Fire Insurance Map. <i>Village of Rhinebeck N.Y.</i> (Source: Library of Congress) Scale: 1"=1245'.....	20
Figure 14: 1940 Aerial image. Village of Rhinebeck, Dutchess County. (Source: Dutchess County Parcel Access) Scale: 1"=130'.....	21
Figure 15: 1955 Aerial image. Village of Rhinebeck, Dutchess County. (Source: Dutchess County Parcel Access) Scale: 1"=120'.....	22
Figure 16: 1970 Aerial image. Village of Rhinebeck, Dutchess County. (Source: Dutchess County Parcel Access) Scale: 1"=115'.....	23
Figure 17; 2004 Aerial image. Village of Rhinebeck, Dutchess County. (Source: Dutchess County Parcel Access) Scale: 1"=135'.	
Figure 18: Dutchess Shepherd Bulkeley School. Phase 1B Archaeological Field Reconnaissance Survey. Scale 1" = 200'.....	33

## LIST OF TABLES

Table 1: Soil Unit Descriptions (Natural Resources Conservation Service) .....	5
Table 2: Previously Recorded Archaeological Sites within one mile-radius.....	8

## LIST OF PHOTOGRAPHS

Photo 1: The former Bulkeley School is located in the center of the Project Parcel. View to the northwest.....	6
Photo 2: The southern portion of the Parcel contains an asphalt covered parking lot. View to the northwest.....	6
Photo 3: Buried utilities and a playground are in the western portion of the parcel. View to the south. ....	7
Photo 4: Buried utilities and equipment are located on the northern side of the school building. View to the southwest... ..	7
Photo 5: The northern side of the building is constructed of cinderblock, and painted red. View to the south. ....	25
Photo 6: Access points on the eastern side of the building are below grade. View to the south. ....	25
Photo 7: View to the south from the northern boundary of the Project Parcel. ....	26
Photo 8: The northern portion of the parcel consists of mown lawns. View to the north. ....	26
Photo 9: Transects 1 and 2 began near East Market Street. View to the west.....	30
Photo 10: The landscape on the southern side of the school building is covered with asphalt. View to the north. ....	30
Photo 11: View to the southeast from the western side of the school building.....	31
Photo 12: A shed is located in the northwestern portion of the Project Parcel. View to the north, of the location of TR 5. ....	31
Photo 13: Stormwater drains are located in the parking area, in the southern portion of the Parcel. View to the west. ....	32
Photo 14: Deep tests, completed by the owner for proposed septic systems show extensive disturbance and building debris to the north of the school building. ....	32

## I. PHASE 1A LITERATURE SEARCH AND SENSITIVITY ASSESSMENT

### A. DUTCHESS SHEPHERD BULKELEY SCHOOLHOUSE PROJECT DESCRIPTION

In February of 2023, Hudson Cultural Services (HCS) was retained by Dutchess Shepherd LLC, to complete a Phase 1A Literature Search and Sensitivity Assessment and Phase 1B Archaeological Field Reconnaissance Survey of the proposed Dutchess Shepherd Bulkeley Schoolhouse Project, located at 6 Mulberry Street in the Village of Rhinebeck, Dutchess County, New York.

The purpose of the Phase 1 Cultural Resources Survey is to determine whether previously identified cultural resources (historic and archaeological sites) are located within the boundaries of the proposed project, and evaluate the potential for previously unidentified cultural resources to be located within the boundaries of the Area of Potential Effect (APE). All work was completed in accordance with the *Standards for Cultural Resource Investigations and the Curation of Archeological Collections* published by the New York Archeological Council (NYAC) and recommended for use by New York State Office of Parks, Recreation and Historic Preservation (OPRHP). The report complies with New York State OPRHP's *Phase 1 Archaeological Report Format Requirements*, established in 2005.

The background research, as well as the cultural and environmental overviews, were completed by Franco Zani Jr. and Beth Selig, MA, RPA, President and Principal Investigator with HCS. Phase 1B testing was completed under the direction of Franco Zani Jr. and Beth Selig. A site visit was conducted by Beth Selig on February 22, 2023 to observe and photograph existing conditions within the Project. The information gathered during the walkover reconnaissance is included in the relevant sections of this report.

The Proposed Dutchess Shepherd Bulkeley Schoolhouse Project in Rhinebeck (hereafter "the Project Parcel") is a ±1.44 acre (0.58 h) parcel in the Village of Rhinebeck. The Project Parcel is comprised of one large parcel which will be subdivided into five parcels as part of the overall project. The Parcel is bounded to the south by South Street, to the east by Mulberry Street, to the north by East Market Street and to the west by residential structures. The proposed undertaking consists of constructing residential structures with associated infrastructure. The existing school will be retained, and converted into apartments.

The Project Parcel is a vacant school, surrounded by lawns, parking lots, a playground and buried utilities. With the exception of the western boundary, a chain link fence encloses the property. The southern portion of the parcel is covered with asphalt.

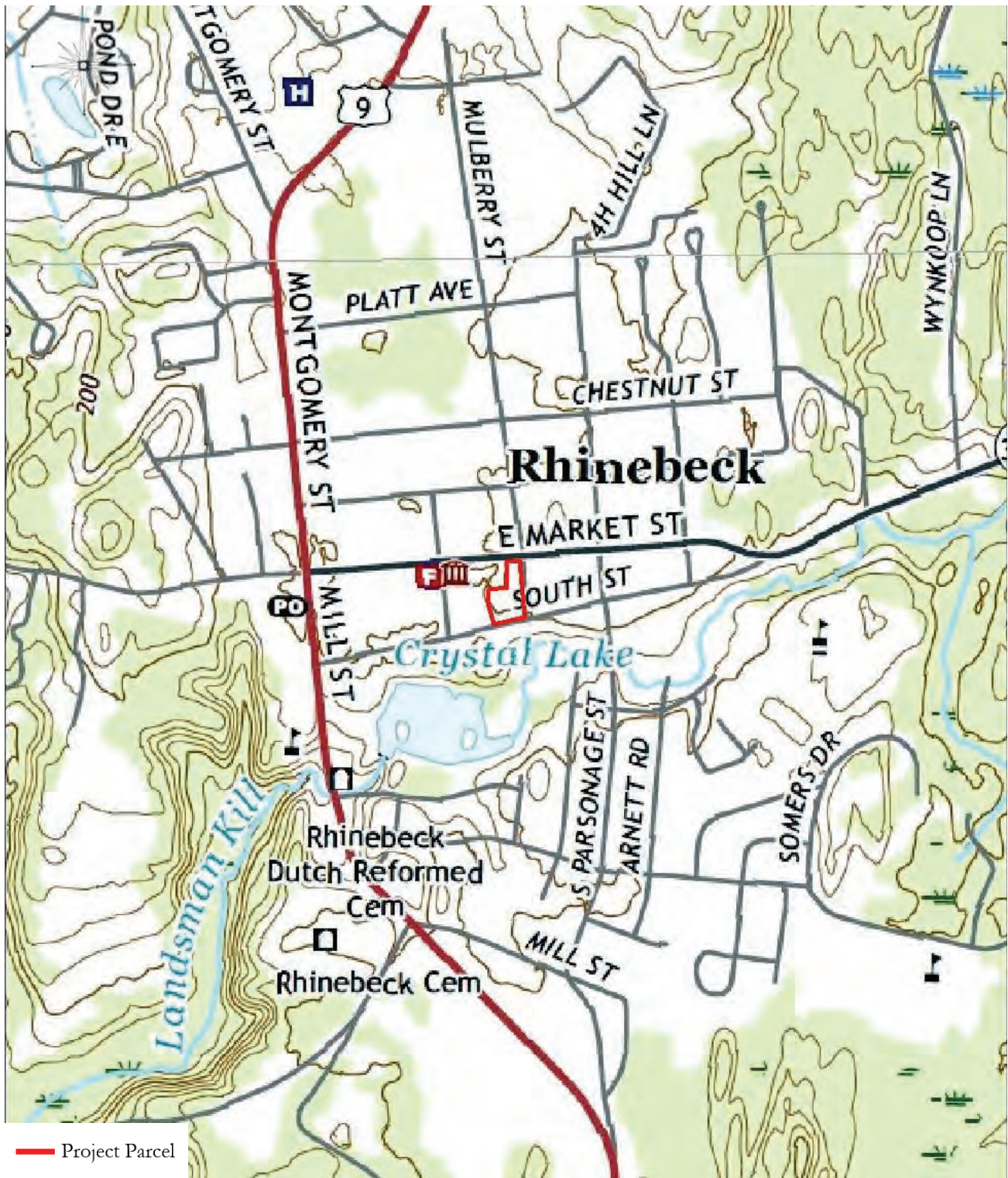


Figure 1: 2019 USGS Topographical Map. Kingston East, NY Quadrangles. 7.5 Minute Series. (Source: USGS.gov.) Scale: 1=1,000'.



Figure 2: 2021 Aerial image showing the location of the Project Parcel (Source: New York GIS Clearinghouse). Scale: 1"=150'.

## B. ENVIRONMENTAL CONDITIONS

The landscape within the Project Parcel is currently cleared, urban land that is maintained as lawn, with parking lots on the southern side of the school building. The elevation of the parcel is about 200' (61 m) Above Mean Sea Level (AMSL).

### ECOLOGY

The Project APE lies within the Eastern Broadleaf Forest. This mountainous region is in the transition zone between the boreal spruce–fir forest to the north and the deciduous forest to the south. Growth form and species are very similar to those found to the north, but red spruce tends to replace white spruce (Bailey 1995; Bryce et al. 2010).

### GEOLOGY

The Project APE is located within the Hudson–Mohawk Lowlands, adjacent to the Catskill Mountains Physiographic Province. The Catskills rise considerably higher than the neighboring parts of the upland. Summit elevations exceed 2000' and some peaks are over 4000'. The mountainous character of the Catskills is due to the action of glaciers and streams carving deep valleys in the flat-lying, stratified sandstones and shales. These sedimentary stones are capped in the high areas with resistant conglomerates that are the bedrocks of the Catskills. The topography is controlled by the bedrock with steep valley sides being a normal occurrence. Minor landforms in the valleys are outwash, kames, kame moraines, deltas, alluvial flats and lacustrine plains. Upland deposits are predominantly glacial tills that are stony or contain flagstones. The only extensive lacustrine area is near Gilboa in Schoharie County. Soils on the other minor landforms are mostly water-laid deposits of granular material (Spectra 2004).

Specifically, the Project APE lies in the Northern Glaciated Shale and Slate Valleys. The Northern Glaciated Shale and Slate Valleys contain broad, irregular rolling to hilly valleys underlain by slaty shale and fine-grained sandstone covered by glacial drift. (Bryce et al. 2010). Escarpments of limestone in the east mark the descent into the Hudson Valley.

### DRAINAGE

There are no water sources located within the boundaries of the parcel. Stormwater drains are located within the village streets, and the overall landscape generally drains to the xx to the Landsman Kill.

### SOILS

Soil surveys provide a general characterization of the types and depths of soils that are found in an area. The characteristics of the soils within the Project Parcel have an important impact on the potential for the presence of cultural material, since the types of soils present affect the ability of an area to support human populations. The Soil Survey's mapped boundaries are considered approximate, as they generally correspond poorly to the actual boundaries of landforms and soil types within an area. The Natural Resources Conservation Service indicates that the soils within the Parcel are a mix of channery and gravelly silt loam, and urban land.



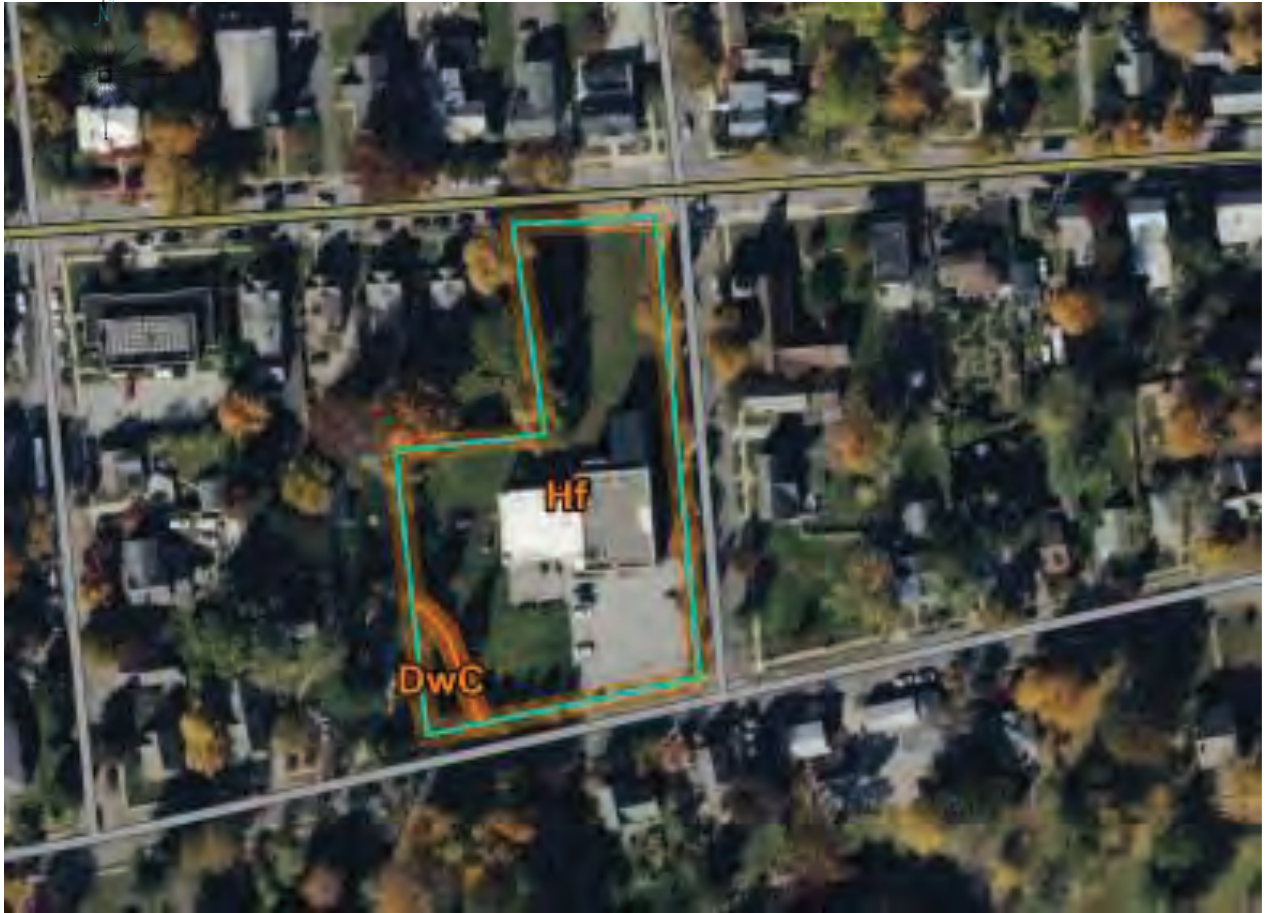


Figure 3: Aerial Image showing soil units within the Project Parcel. (Source: Natural Resources Conservation Service.) Scale: 1"=150'.

<b>Table 1: Soil Unit Descriptions (Natural Resources Conservation Service)</b>					
<b>Map Symbol</b>	<b>Map Unit Name</b>	<b>Soil Horizons &amp; Texture</b>	<b>Slope</b>	<b>Drainage</b>	<b>Landform</b>
DwC	Dutchess-Cardigan complex, rolling, rocky	H1 - 0 to 8 inches: silt loam H2 - 8 to 28 inches: silt loam H3 - 28 to 86 inches: channery silt loam	5 to 16%	Well drained	Ridges, hills
		H1 - 0 to 8 inches: channery silt loam H2 - 8 to 20 inches: channery loam H3 - 20 to 30 inches: channery silt loam H4 - 30 to 34 inches: unweathered bedrock			
Hf	Haven-Urban land complex	H1 - 0 to 12 inches: loam H2 - 12 to 23 inches: gravelly loam H3 - 23 to 72 inches: stratified very gravelly sand	0 to 3%	Well drained	Outwash plains
		H1 - 0 to 6 inches: variable			



Photo 1: The former Bulkeley School is located in the center of the Project Parcel. View to the northwest.



Photo 2: The southern portion of the Parcel contains an asphalt covered parking lot. View to the northwest.



Photo 3: Buried utilities and a playground are in the western portion of the parcel. View to the south.



Photo 4: Buried utilities and equipment are located on the northern side of the school building. View to the southwest.

C. RECORDED ARCHAEOLOGICAL SITES AND SURVEYS

On February 23, 2023 HCS reviewed the combined site files of the New York State Office of Parks, Recreation, and Historic Preservation (OPRHP) and the New York State Museum (NYSM) for information regarding previously recorded archeological sites within one mile (1.6 km) of the Parcel. HCS also consulted regional Native American sources (e.g., Beauchamp 1900; Parker 1920; Ritchie 1980; Ritchie and Funk 1973) for descriptions of regional archeological sites.

PREVIOUSLY RECORDED ARCHAEOLOGICAL SITES

Nineteen (19) previously documented archaeological sites and one (1) New York State Museum area have been identified within a one mile-radius of the Project Parcel boundaries. The historic sites are Map Documented Structures (MDS) that have been identified on the nineteenth century landowner maps. A number of these locations have been disturbed by modern development or do not have any visible surface remains.

<b>Table 2: Previously Recorded Archaeological Sites within one mile-radius</b>				
<b>Site Number</b>	<b>Site Name</b>	<b>Distance from Project</b>	<b>Time Period</b>	<b>Site Type Materials Recovered</b>
NYSM 7669	Rhinebeck Rockshelter	Includes Project APE	Precontact	Large generalized area that includes the entirety of the Village of Rhinebeck.
2716.00096	Rhineson Corporation Site	3158.6'/962.7 m	Precontact	Undetermined Precontact site
2716.000961	Baptist Home Precontact Site	4333.1'/1.32 k	Precontact	Undetermined camp site.
2716.000969	Rhinebeck Site 5	3420.4'/1.04 k	Precontact	Middle Archaic to Woodland; habitation site
2716.00097	Rhinebeck Site 6	4134.7'/1.26 k	Precontact	Undetermined Precontact site
2716.000971	Rhinebeck Site 7	4667.9'/1.42 k	Precontact	Undetermined Precontact site
2716.000972	Rhinebeck Site 8	4501.1'/1.37 k	Precontact	Undetermined Precontact site; chert debitage, scraper.
2716.000973	Rhinebeck Site 9	4871.8'/1.48 k	Precontact	Undetermined Precontact site
2716.000975	Knollwood Precontact Site	3975.6'/1.21 k	Precontact	Late Archaic site. Poplar Island pp.
2716.000987	Grasmere Precontact Site	4833.8'/1.47 k	Precontact	Undetermined Precontact site; 2 chert debitage
2716.001032	Darling Historic Site	2986.1'/910 m	Historic	Early 19 <sup>th</sup> century homestead.
2750.000432	Rhinebeck Site 1	2472.4'/753.5 m	Precontact	Middle Archaic to Woodland
2750.000433	Rhinebeck Site 3	2867.5'/874 m	Precontact	Middle to Late Archaic

2750.000434	Rhinebeck Site 4	3507.5'/1.07 k	Precontact	Middle Archaic to Woodland habitation site
2750.000435	Spring Historic Site	1553.4'/473.4 m	Historic	Late 18 <sup>th</sup> to 19 <sup>th</sup> century historic dump. Ceramics, tobacco pipes, glass, nails and faunal remains recovered.
2750.000436	Rhinebeck Site 2	2670'/813.8 m	Precontact	Middle Archaic to Woodland habitation site
2750.000437	Rhinebeck Site 10	3123.1'/952 m	Precontact	Late Archaic to Woodland habitation site
2750.000438	Rhinebeck Site 11 Historic	2668.6'/813.4 m	Historic	Remains of Late 18 <sup>th</sup> C dwelling and barn. Ceramics, glass and pipe fragments.
2750.000439	Rhinebeck Site 2	2628.6'/801.2 m	Precontact	Middle Archaic to Woodland habitation site
2750.00044	Rhinebeck Wagon Shop Historic Site	1488.2'/453.6 m	Historic	Late 19 <sup>th</sup> to 20 <sup>th</sup> c wagon shop.

PREVIOUSLY COMPLETED ARCHAEOLOGICAL SURVEYS

As part of the research for this report, surveys completed for projects in the general area were consulted. Eleven (11) surveys and 1 (one) building survey have been completed within a one-mile radius of the Parcel. These surveys have identified areas of Native American occupation sites and eighteenth to twentieth century period domestic sites. These identified sites, included in Table 2, will not be impacted by the proposed Project.

D. NATIVE AMERICAN CONTEXT

During the Paleoindian period, mobile bands of hunter-gatherers occupied what is now New York State. These bands exploited the resources of the landscape by hunting game and gathering plants. Paleoindian sites have been in the upland regions a short distance from the Hudson River (Ritchie and Funk 1976). Frequently these sites are associated with sources of stone, as is the case with a site in Greene County where a quarry-workshop complex has been excavated. More frequently, the sites appear to have been temporary campsites located where it would be possible to watch for game as it moved across the landscape (Ritchie 1980).

With the lowering of the water table during the Archaic period, subsistence methods and technologies changed in response to climatic warming. This was accompanied by an increase in vegetation density and diversity, changing faunal migrations and a change in sea levels (Sirkin 1977). The Archaic Period was likely a time of incipient sedentism among the inhabitants of the area. Changes in settlement and subsistence patterns that occurred during the Late Archaic period reflect an increased exploitation of coastal and riverine resources (Snow 1980). Ground stone food processing tools are more common, reflecting an increase in processed plant resources in the diet. Projectile points commonly found at Late Archaic sites include narrow stemmed, broad stemmed and side notched types (Snow 1980). The Laurentian Tradition of the Late Archaic is the most represented throughout New York State, and is subdivided into a series of phases: Vergennes, Vosburg, Sylvan

Lake, River and Snook Kill. Ground stone tools appear, and steatite bowls are associated with the later part of this time period (Pretola and Freedman 2007).

The Woodland period is distinguished from the Archaic in part, by the use of ceramics. Horticulture, although practiced in other parts of North America at an earlier date, does not appear in the Hudson River Valley until c. 1000 AD (Funk 1976). The soil and moisture requirements for the cultivation of maize, beans, and squash created a marked change in the pattern of land use and the selection of locations for villages (Hart and Brumbach 2005). It was no longer necessary for the entire group to move from place to place following a seasonal round of migration fueled by fluctuating sources of food. Cord marked ceramics became common during the Middle Woodland period, and incised vessels, many with a collar area, are typical of Late Woodland cultures (Lavin et al 1993).

Up to the time of Contact, two Algonquin-speaking Indian nations, referred to locally as the Wappinger and the Mohigan (Mahican), occupied the southern and northern sections of Dutchess County. These tribal people were sedentary, living in small permanent villages and growing crops such as maize and squash (Cronon 1983). While the original population of the Wappinger is unknown, Snow suggests that it may have reached 50,000 people (1980). The introduction of small pox by the Dutch reduced the Native Population to less than 1000 by the year 1700 (MacCracken 1956).

#### E. HISTORIC CONTEXT

Dutchess County, one of New York's original counties, was created in 1683, and at that time included all of Putnam County and part of Columbia County (Cronon 1983). The county was divided into thirteen patents, with the Rombout Patent being one of the earliest. Dutch settlement on the patents began in the late 1600s, with English Quakers from Rhode Island and Long Island moving into the eastern part of the county in the 1740s (Cronon 1983)

The Town of Rhinebeck was made up of three early land patents; the "water lots" section of the Nine Partners Patent of 1697, the Pawling patent of 1696, and the Fauconnier Patent of 1705. As early as 1730, a part of the Fauconnier Patent was known as the Hyde Park Patent (Rhinevault 2009). Settlement began in the Town of Rhinebeck as early as 1735, when Jacob Stoutenburgh, a Dutchman and trader from Westchester, purchased Water Lot 9 on the Nine Partners Patent on the south side of Crum Elbow Creek (Smith 1877). Stoutenburgh, had been purchasing property in Dutchess County for some time when he moved his wife and eight children up the Hudson to the area. Dr. John Bard, an eminent New York City doctor, married Suzanne Valleau, who was the granddaughter of Peter Fauconnier. Following Fauconnier's death, Bard purchased a portion of the Fauconnier Patent and continued to buy land until he owned all of the lands of the original Fauconnier Patent (Rhinevault 2009).

By the 1790's, considerable settlement had taken place along the Albany Post Road, including the hamlets of Staatsburg at the north end of town and Hyde Park, which was to the south and a half mile east of the Hudson River. The Town of Rhinebeck was established in 1821 (Hasbrouck 1909). The eastern portion of the Town of Rhinebeck includes the hamlet of Staatsburg which was first settled by Dr. Samuel Staats in 1715. He purchased the land from the owner of the land patent, Henry Pawling (Smith 1877). By 1813 Staatsburg had a post office, and was primarily a farming community with grain being the main crop. Several mills were established on Crum Elbow Creek to grind the grain. In addition to gristmills, there were also sawmills, a plaster mill, a fulling mill, and mills that made nails and other types of tools. Sloops docked daily at the Hudson

River piers to transport grain and other products to New York City, including hay for the New York City police horses. There were also other industries located near the mouth of Crum Elbow Creek, including shipbuilding and ship repair. The Hudson River also provided important resources such as sturgeon. The harvesting of sturgeon provided employment for a significant number of Hyde Park residents (Rhinevault 2009). In the late nineteenth century the hamlet of Staatsburg became the location of ice harvesting and storage industries. During the winter months, the Mutual Benefit Ice Company and the Knickerbocker Ice Company would cut river ice and store it until it could be shipped to markets in Albany and New York.

In 1847, construction began on the Hudson River Railroad, which ran along the bank of the River through Staatsburg. Railroad service began in 1849, although the entire span between New York and Albany was not completed until 1851. In 1869, the New York Central and Hudson Railroad replaced the Hudson River Railroad (Frederiksen 1962).

The Flatts, as William Traphagen called the village, or Rhinebeck Flatts, was located at the intersection of the well-traveled Sepasco Trail and King's Highway. Landsman Kill which flowed parallel to Sepasco Trail provided the settlers with their primary source of power. Grist, woolen, saw and paper mills were concentrated around along the Landsman Kill where it intersected with the King's Highway. Soon there was a wagoner, a cooper, a seinemaker, a shoemaker, a mason, a saddle and harness maker, a linen weaver, a tailor, a gunsmith, a tanner, a cordwainer, a wheelwright, a blacksmith and a carpenter in the neighborhood (Morse 1908).

#### HISTORY OF BULKELEY SCHOOL

In 1805, the public school and district system was introduced in the Town of Rhinebeck. The first village school was the Union Free School District No. 5, and initially consisted of an oblong one-story two-room structure (Morse 1908). From 1811 to 1839 school was kept for a short time every year in different parts of the district by itinerant teachers. In 1839, the South Street (Mulberry Street) lot was purchased and a school building was built. In 1844, the district was divided and second school building was constructed on Oak Street. In 1868, a new school building replaced the original South Street building which was in desperate need of repairs. The new structure, which featured high ceilings and spacious halls, was designed and built by Peter M. Fulton. The structure was enlarged to accommodate the growing number of students in the Village of Rhinebeck, and because new construction was financially practical. The school accommodations remained the same until 1901, when a large addition was made to the building (Morse 1908).

The Sanborn Fire Insurance Maps (Figures 10, 12-13) show that the addition was constructed on the southern side of the building. The building was expanded again in 1912, and is identified as the Rhinebeck High School. The additions were reportedly completed in 1903, 1911 and 1921 (Poughkeepsie Journal 1939a). On April 21, 1939 the "old wing" of the building burned down. The original portion of the building was destroyed along with the heating plant for the newer portions of the building. The fire doors protected the newer portions of the school (Poughkeepsie Eagle News 1939a) Adolph Knappe was hired by the school district to design the improvements and renovations (Poughkeepsie Eagle News 1939b). The building was not immediately rebuilt, as plans were in place to centralize the district, which occurred in 1941. The Rhinebeck District purchased a 28-acre site, and began making improvements for a new school building. (Poughkeepsie Journal 1949). In the late 1940's the village residents rejected plans to build a new school building, rather than improve the Bulkeley school building (Poughkeepsie Journal 1948). The 1940 aerial image (Figure 14) shows that between 1912 and 1940 the footprint of the building changed, with the 1921

addition on the western side of the building. The northern and southern “wings” of the building were removed, presumably as a result of the fire. The school gets its name from the president of the School board, Dr. H. S. Bulkeley (Poughkeepsie Eagle News 1938).



Figure 4: Image of the Bulkeley School House. Circa 1870.

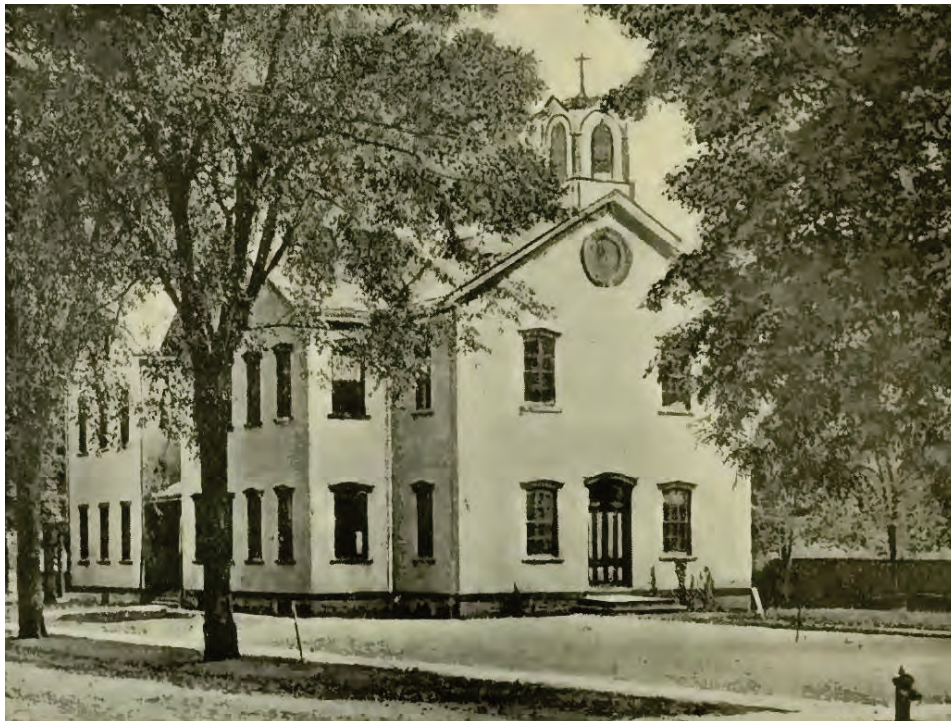


Figure 5: Image of the Bulkeley School with southern addition. Circa 1908. (Source Morse 1908).





Figure 6: Post card of the school building c. 1928. (Source: New York Heritage digital collections). This image shows the additions from the early 1900s, and the northern addition completed by 1912.

In 1952, a new school building was opened, and the Mulberry Street School was used by the lower elementary grades (Poughkeepsie Journal 1952). The 1955 aerial image (Figure 15) shows that a small addition has been added to the northern side of the building. By 1963, the school building, which consisted primarily of the 1905 and circa 1955 additions, was evaluated for modernization by W. Parker Dodge and Associates (Poughkeepsie Journal 1963). In 1970, a plan to construct an 8-room addition on the existing school at Mulberry Street was presented to the school board (Poughkeepsie Journal 1970). This addition was not completed. In 1977 the school board voted to keep the school open, despite inadequacies of space and condition (Trilling 1977). The school was sold in 1997 to Good Shepherd Catholic Church (Haviland 1996).

#### CARTOGRAPHIC RESEARCH

HCS examined historical maps of Dutchess County to identify possible structures, previous road alignments and other landscape features or alterations that could affect the likelihood that archeological and/or historic resource might be located within the Project Parcel. These maps are included in this report, with the boundaries of the Project Parcel superimposed. Nineteenth century maps frequently lack the accuracy of location and scale present in modern surveys. As a result of this common level of inaccuracy on the historic maps, the location of the Project Parcel is drafted relative to the roads, structures, and other features as they are drawn, and should be regarded as approximate. The historic maps included in this report depict the sequence of road construction and settlement/development in the vicinity of the Project Parcel.



Figure 7: 1850 J.C. Sidney *Atlas of Dutchess County, New York*. (Source: Library of Congress) Scale: 1" = 1000'.

The earliest map included in this report is the 1850 *Atlas of Dutchess County, New York*. No structures are shown within the Project Parcel, although there is a building located on the western boundary. The village is densely settled, but no details are shown for the buildings except the tavern and churches within the villages.

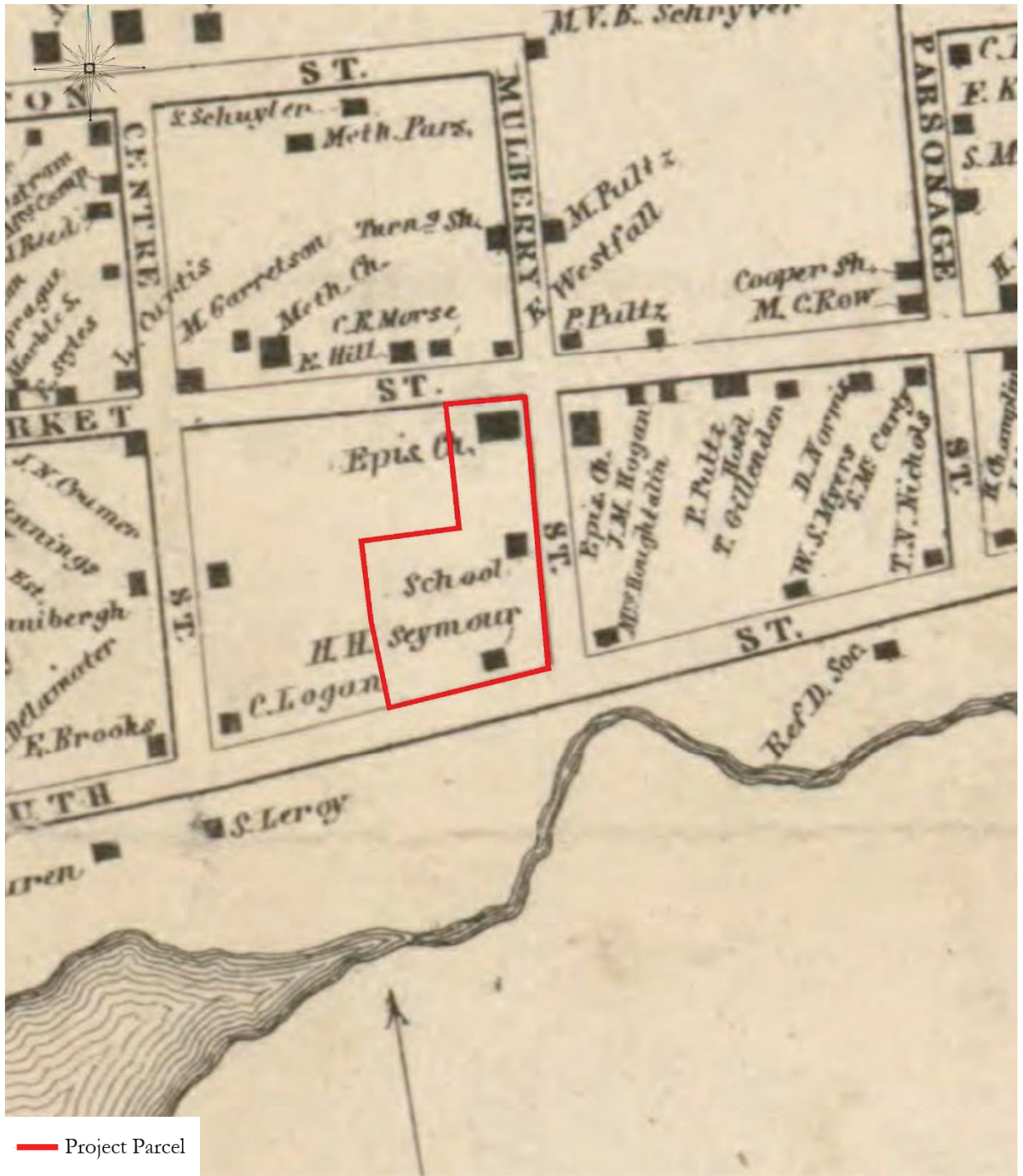


Figure 8: 1858 J. E. Gillette. *Map of Dutchess County, New York*. (Source: Library of Congress) Scale: 1” =200’

The second map consulted for this report is the J.E. Gillette *Map of Dutchess County New York* published in 1858. This map shows three buildings within the boundaries of the Project Parcel. The Seymour residence is located near South Street, the school is in the center of the parcel near Mulberry Street, and a building identified as the Episcopal Church, at the intersection of Market Street and Mulberry Street.



Figure 9: 1867 F.W. Beers. *Village of Rhinebeck, Atlas of the County of Dutchess, N. Y.* (Source: David Rumsey Cartography Associates) Scale: 1"=335'.

The next consulted for this report is the 1867 *Atlas of Dutchess County, New York, Village of Rhinebeck* map surveyed by Beers. This map shows Schoolhouse number 5 is within the Project Parcel. Two structures owned by E.M. Smith are located to the west and southwest of the school. Mrs. Miller owned the vacant lot to the north of the school.

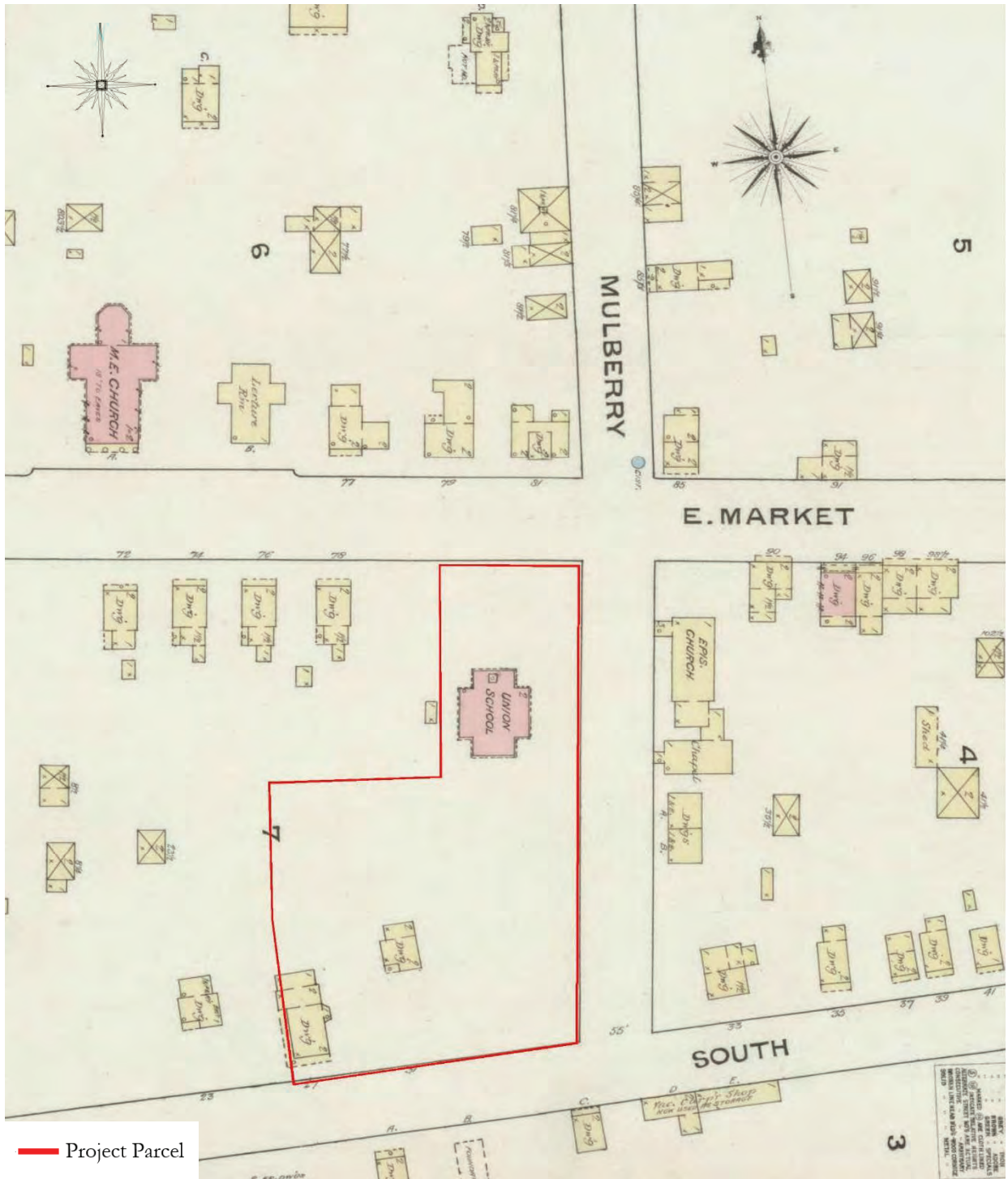


Figure 10: 1886 Sanborn Fire Insurance Map. *Village of Rhinebeck N. Y.* Scale: 1"=112'. (Source: Library of Congress) Scale: 1"=112'

The 1886 Sanborn Fire Insurance Map shows the Union School in the northern portion of the Project Parcel. The two-story brick building is shown with a wooden cupola on the northern side of the roof. Two wood framed residential buildings are shown in the southern and southwestern portions of the Project Parcel. The school is cruciform shape with the main entrance on the northern side of the building.

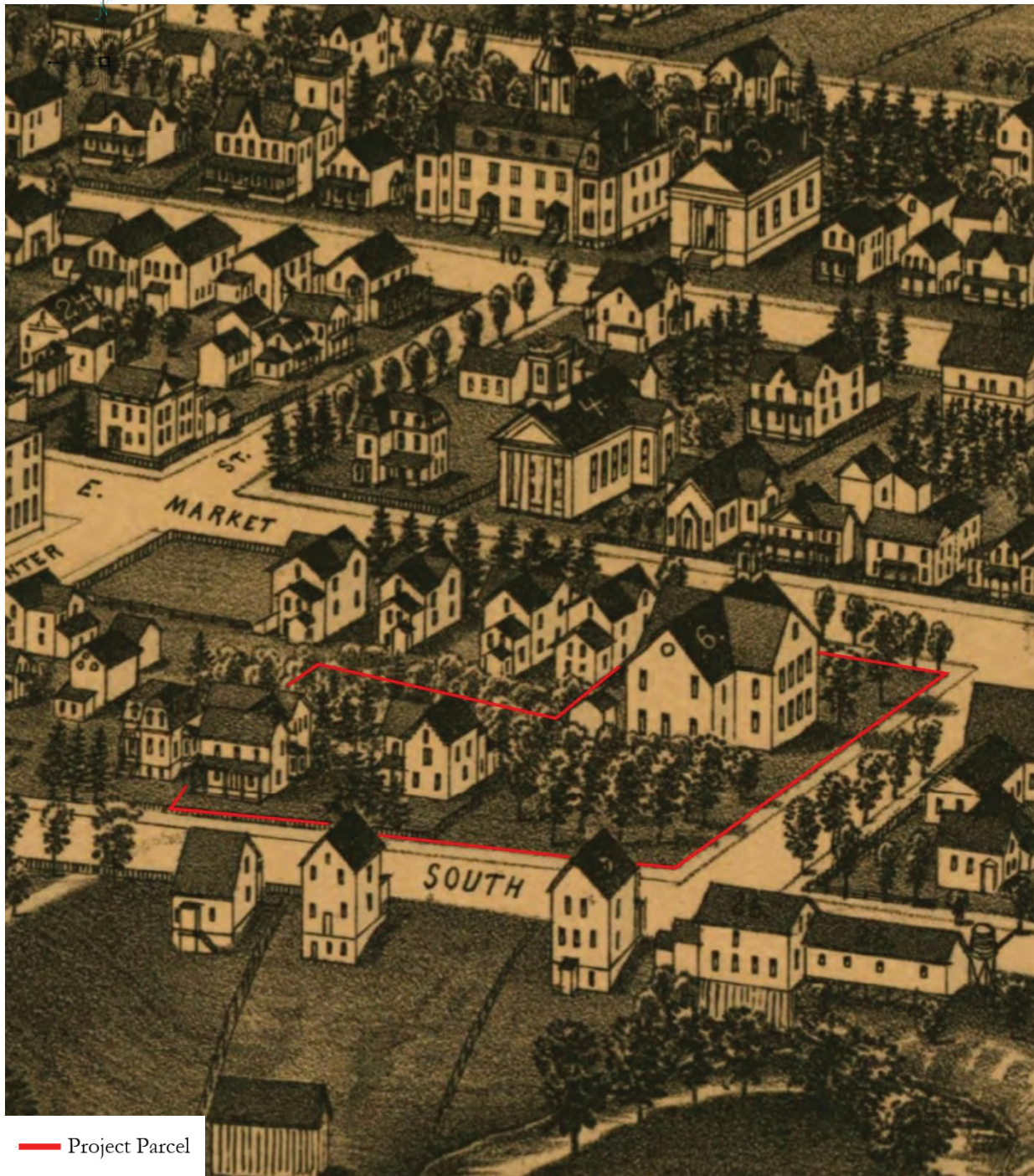


Figure 11: 1890 L.R. Burleigh. *Birds Eye View of the Village of Rhinebeck N. Y.* (Source: Library of Congress) Scale: 1"=75'.

The 1890 L.R. Burleigh *Birds Eye View of the Village of Rhinebeck*. The schoolhouse is shown within the northern and central portion of the Parcel, with residential structures to the south and west. The residential structures front along South Street. The school is shown as a two story building, with a wooden cupola on the northern side of the roof. The lawn areas to the south are shown as containing decorative trees.



Figure 12: 1905 Sanborn Fire Insurance Map. *Village of Rhinebeck N. Y.* (Source: Library of Congress) Scale: 1"=125'.

By 1905 the school has been altered, with an addition on the southern side of the existing building. The addition is shown as constructed of brick, without the decorative wood cornice of the earlier structure. The Parcel also contains two residential buildings that have wooden shed located to the north of the building.



Figure 13: 1912 Sanborn Fire Insurance Map. *Village of Rhinebeck N. Y.* (Source: Library of Congress) Scale: 1"=1245'.

By 1912 an addition has been constructed on the northern side of the original school structure. The 1868 structures has been incorporated into the larger brick high school building. To the south and southwest, the residential structures are shown on their own lots. The school is two stories in height, and is identified as being fully electric with a furnace and hot water plant.





Figure 14: 1940 Aerial image. Village of Rhinebeck, Dutchess County. (Source: Dutchess County Parcel Access) Scale: 1"=130'.

The 1940 aerial image indicates that dramatic changes have taken place to the school building and surrounding property. The structures shown consists of the circa 1905 addition, with a new addition (c. 1921) located on its western side. A newspaper article identifies three additions, the 1903, 1912 and a 1921. The northern portion of the parcel has been graded and leveled, likely the result of the burned portions of the building being removed. The residential structure in the southwestern corner of the Parcel is still present. Due to the vegetation and tree cover, is unclear if the second residential building is still present.



Figure 15: 1955 Aerial image. Village of Rhinebeck, Dutchess County. (Source: Dutchess County Parcel Access) Scale: 1"=120'.

The 1955 aerial image indicates shows that a small addition has been constructed on the northern side of the building. The residential structures in the southern and southwestern portions of the Parcel have been removed, and the area graded as lawn.



Figure 16: 1970 Aerial image. Village of Rhinebeck, Dutchess County. (Source: Dutchess County Parcel Access) Scale: 1"=115'.

The 1970 aerial image shows that there have been few changes to the parcel. The southern side of the building appears to be gravel or recently graded.



Figure 17: 2004 Aerial image. Village of Rhinebeck, Dutchess County. (Source: Dutchess County Parcel Access) Scale: 1"=135'.

The 2004 aerial image shows that the southern portion of the Parcel is covered with asphalt, and utilized as a parking lot. A playground has been constructed on the western side of the building.



Photo 5: The northern side of the building is constructed of cinderblock, and painted red. View to the south.



Photo 6: Access points on the eastern side of the building are below grade. View to the south.



Photo 7: View to the south from the northern boundary of the Project Parcel.



Photo 8: The northern portion of the parcel consists of mown lawns. View to the north.

## F. NATIONAL REGISTER ELIGIBLE/LISTED SITES

The OPRHP files were reviewed to identify structures on or in the vicinity of the Project APE that have been listed on the National Register of Historic Places (NRL) or identified as National Register Eligible. The Project Parcel is located within the boundaries of the Rhinebeck Village Historic District and adjacent to the Hudson River Historic District and the Village of Rhinebeck Historic District Boundary Increase.

The Project Parcel, contains the Bulkely Schoolhouse, which contributes to the to the Rhinebeck Village Historic District Boundary Increase. The Hudson River Historic District and the Rhinebeck Village historic District are located within a one-half mile radius of the Proeject Parcel. Five individually listed properties are located within a one-half mile radius of the Project Parcel. These properties which include the Benner House, the Rhinebeck Post Office, the Astor Home for Children, the Henry Delamater House, and Grasmere will not be directly impacted by the proposed project

## G. ASSESSMENT OF SENSITIVITY FOR CULTURAL RESOURCES

### PRECONTACT SENSITIVITY

Precontact period archaeological sensitivity of an area is based primarily on proximity to previously documented precontact archaeological sites, known precontact resources, and physiographic characteristics such as topography and proximity to fresh water. Precontact resources have been located within Rhinebeck and along the Landsman Kill. The project's location, near sources of fresh water, along with the presence of level terrain within the Project Parcel, makes this landscape sensitive for precontact cultural resources. this potential has been eliminated due to the successive episodes of construction and demolition, along with grading of soils that have occurred within the boundaries of the parcel.

### HISTORIC SENSITIVITY

The Project Parcel has held a school since the 1860s, and the southern portion has been occupied by residential structures through the late nineteenth and early twentieth century. In the mid-nineteenth century a church was located in the northern portion of the Parcel, that was removed by the mid-late nineteenth century. This northern area has been disturbed through the construction and removal of a school addition and the original school building. The southern portion of the parcel, outside the area of the asphalt covered parking area retained the potential to contain historic resources.

## H. SUMMARY AND RECOMMENDATIONS

The environmental conditions present within and adjacent to the Project Parcel indicate that the area is sensitive for historic cultural resources. It is therefore recommended that a Phase 1B Archaeological Field Reconnaissance Survey be undertaken on those undisturbed areas within the Project Parcel that will be impacted by the proposed Dutchess Shepherd Bulkeley Schoolhouse Project.

## II. PHASE 1B ARCHAEOLOGICAL FIELD RECONNAISSANCE SURVEY

### I. ARCHAEOLOGICAL SURVEY METHODOLOGY

Results of the Phase 1A confirmed that the Project Parcel is located in an area of historic activity. Phase 1B field investigations took place on March 7, 2023 under the supervision of Franco Zani Jr and Beth Selig, MA, RPA.

Areas selected for subsurface testing were identified during an intensive walkover inspection which evaluated the landscape to determine areas of prior disturbance, slope in excess of 12% grade, saturated or wet soils, and documented evidence of former land usage. Shovel tests were excavated at intervals of 50' (15 m) along transects conforming to the land surface and the boundaries of the Project Parcel. The locations of the tests and disturbed areas were recorded on a scaled map that shows surveyed borders and has the locations of the various structures or features identified (Field Reconnaissance Map).

Shovel tests (ST's) approximately 45 cm in diameter were spaced 50 feet apart and excavated at least 10 cm into sterile subsoil, unless impeded by rocks or other obstructions. This subsurface testing strategy was employed in areas of undisturbed soils and areas that did not contain surface water. All excavated soils were screened through 0.25-inch hardware cloth. Shovel test profiles were recorded on standard field forms which included stratigraphic depths, Munsell soil color, texture and inclusions, disturbances and artifacts (Appendix B). The presence of clearly modern materials, such as plastic fragments, modern bottle glass fragments, or twentieth-century architectural materials was noted on field forms, but HCS does not generally collect these materials for analysis or inclusion in the artifact assemblage. If any cultural material was recovered, these finds would be bagged and labeled with standard project provenience information. Following completion of archaeological fieldwork, all recovered materials would be washed, identified, inventoried, and re-bagged in labeled clean 4-mil archival quality plastic bags. All cultural material collected would be identified and described based on material type and standard descriptive characteristics and included in an artifact inventory.

### J. ARCHAEOLOGICAL SURVEY RESULTS

Initially the field methodology included the completion of five (5) transects each containing a various number of shovel tests. However, given the amount of disturbance identified at the ground surface, and the asphalt parking area a number of tests were not completed.

Testing began in the north of the Project Parcel, near the corner of Mulberry and East Market Street. This area, consisting of Transects 1 and 2, was previously cleared and contains a packed gravel road, leach field, and large lawn area. The 1940's aerial (figure x) shows that the ground surface has been graded. Soils in this area consisted of brown gravelly silt loams or gravelly loam overlaying a dark yellowish brown gravelly silt loam. Near the schoolhouse, an intermediate layer of dark brown gravelly loam was found under the brown gravelly silt loam and overlying a yellowish brown clay with packed gravel. Plastic, brick fragments, coal, coal slag and window glass fragments were recovered and discarded.

Transect 3 was behind the school, in an area that was heavily disturbed with buried utilities. Only a single shovel test was done here, finding a brown sandy loam overlaying a very dark grayish brown sandy clay loam with dense gravel overlaying a dark yellowish brown coarse sand and gravel.



Transects 4 and 5 were in the western and southern portions of the Project Parcel. These areas have been disturbed by buried utilities and the construction of a playground and parking lot. Soils here were mixed, with soils consisting of dark brown sandy clay loam with gravel, very dark brown gravelly silty clay loam, dark brown coarse sand and gravel, dark brown gravelly silty clay loam, mixed brown and dark yellowish brown gravelly silt loam or mixed dark brown and dark yellowish brown gravelly sandy loam overlaying dark yellowish brown clay loam with gravel, sandy clay with gravel packed gravel and clay or gravelly clay or a dark grayish brown coarse sand and gravel. Transect 4 shovel test 13, and transect 5 shovel test 16 encountered a large ash layer. Metal, nails, coal, coal slag, slag, brick fragments and window glass were recovered from this layer and discarded in the field. Portions of the school burned in 1939, and it is unclear if the existing dwellings on the lot burned at the same time. The ash layer which contained various type of burned and rusted metal, may be the result of building removal and landscape improvements in the wake of the fire.

#### K. SUMMARY AND RECOMMENDATIONS

In March of 2023, Hudson Cultural Services (HCS) completed a Phase 1A Literature Search and Sensitivity Assessment and Phase 1B Archaeological Field Reconnaissance Survey of the proposed Dutchess Shepherd Bulkeley Schoolhouse Project in the Village of Rhinebeck, Dutchess County, New York. The survey evaluated the portions of the parcel to be disturbed. The Project Parcel of Potential Effect (APE) includes ±1.44 acres (0.58 hectares) of urban landscape. Fifteen (15) shovel tests were completed within the boundaries of the Project Parcel. Coal, ash, coal slag, brick fragments, slag, metal, window glass, plastic and nails were found and discarded. The soil profile within the parcel indicates that disturbance has taken place due to the construction and demolition of portions of the school building and the removal of the residential structures in the southern portion of the Parcel.

It is the recommendation of Hudson Cultural Services that no further archaeological investigation is warranted.

These recommendations are subject to concurrence by the New York State Office of Parks, Recreation and Historic Preservation.



Photo 9: Transects 1 and 2 began near East Market Street. View to the west.



Photo 10: The landscape on the southern side of the school building is covered with asphalt. View to the north.



Photo 11: View to the southeast from the western side of the school building.



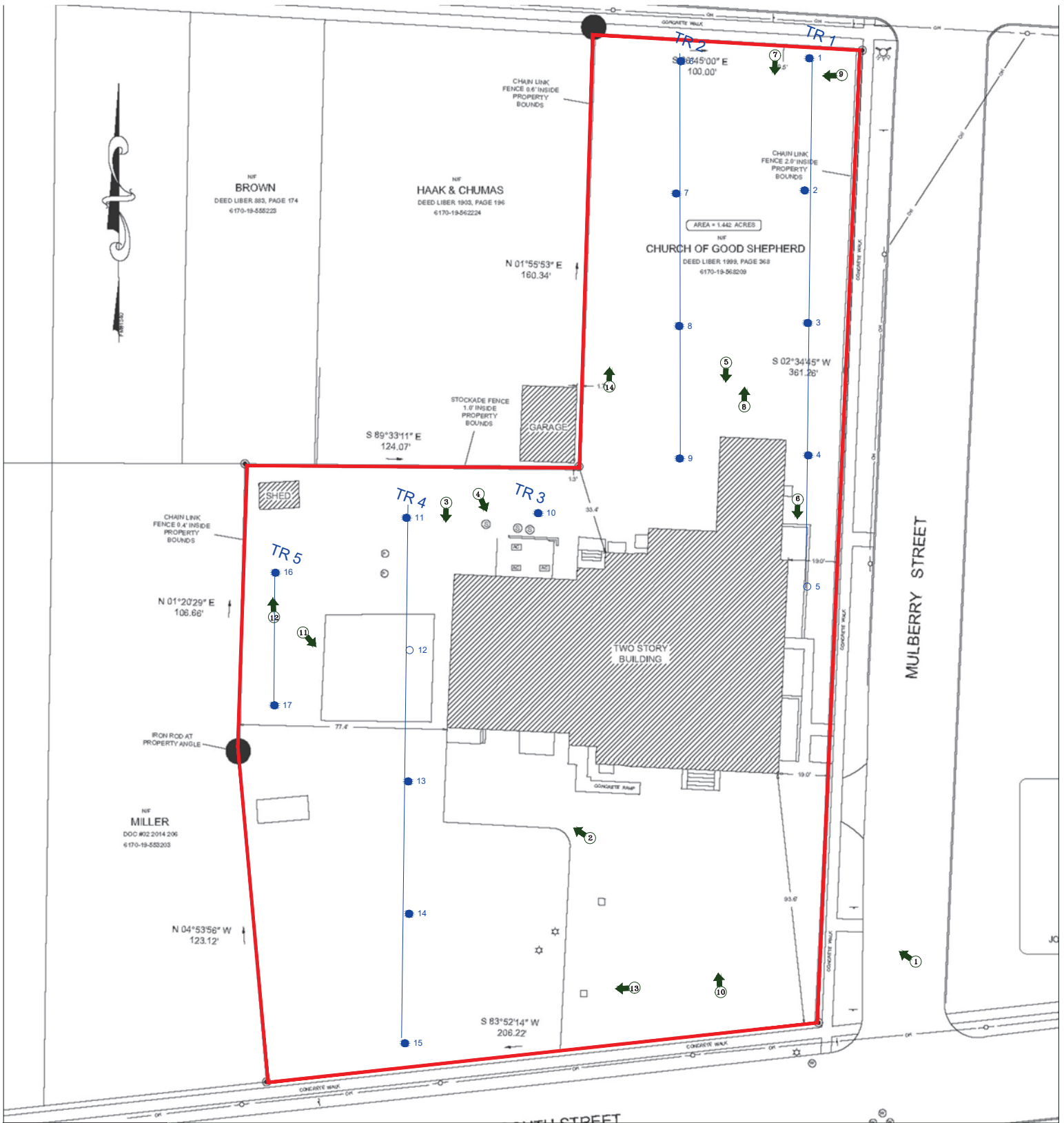
Photo 12: A shed is located in the northwestern portion of the Project Parcel. View to the north, of the location of TR 5.



Photo 13: Stormwater drains are located in the parking area, in the southern portion of the Parcel. View to the west.

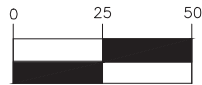


Photo 14: Deep tests, completed by the owner for proposed septic systems show extensive disturbance and building debris to the north of the school building.



**H·C·S**  
Hudson Cultural Services

Figure 18: Dutchess Shepherd Bulkeley School  
Phase 1B Field Reconnaissance Map  
Scale 1" = 50'



( IN FEET )  
1 inch = 50 ft.

- LEGEND**
- ST Sterile Shovel Test Location
  - ST Planned Shovel Test, Not Excavated
  - ➔ ① Photographic View
  - Parcel Boundaries



## L. BIBLIOGRAPHY

- Bailey,  
1995 Description of the Ecoregions of the United States.  
<http://www.fs.fed.us/land/ecosysgmt/index.html>. Accessed March 9, 2023.
- Beauchamp, William  
1900 *Aboriginal Occupation of New York*. New York State Museum Bulletin No. 32: Albany, NY.
- Bachman, Charles and C.H. Corey.  
1858 *Map of Dutchess County, New York from Actual Surveys*. Gillette, Philadelphia, Pennsylvania.
- Beers, F.W.  
1867 *Atlas of New York*. F.W. Beers, A.D. Ellis, and G.G. Soule, New York.  
1891 *Atlas of the Hudson River Valley from New York City to Troy*. Watson and Co.: New York.
- Coles, Christopher  
1789 *A Survey of the Roads of the United States of America*. Christopher Colles, New York.
- Croswell, E.  
1838 *Laws of the State of New York. Passed at the Sixty-First Session of the Legislature*. Wm.A. Gould & Co. Albany.
- de Laubenfels, D.C.  
1975 *Mapping the World's Vegetation: Regionalization of Formations and Flora*. Syracuse University Press.
- Domack, E.W. (Ed.), Lothrop, J.C., Bradley, J.A.,  
2012 *Paleoindian Occupations in the Hudson Valley, New York*. Texas A & M University Press.
- Dunn, S.  
1994 *The Mohican's and Their Land*. Purple Mountain Press. Fleischmann's NY.
- Eisenstadt, Peter ed.  
2005 *The Encyclopedia of New York State*. Syracuse University Press, Syracuse, NY.
- Fisher, Donald W., Yngvar W. Isachsen, Lawrence V. Rickard  
1970 *Geologic Map of New York, Lower Hudson Sheet*. New York State Museum and Science Service Map and Chart Series No. 15. New York State Museum, Albany, New York.
- Flad, Harvey K., Clyde Griffen  
2009 *Main Street to Main Frames: Landscape and Social Change in Hyde Park*. Ed. Thomas Wermuth. State University of New York Press, Albany.
- Fredriksen, Beatrice  
1962 *Our Local Heritage, A Short History of the Town of Rhinebeck*. Hyde Park, New York: Cross Road Press.
- Funk, Robert E.  
1976 *Recent Contributions to Hudson Valley Prehistory*. New York State Museum Memoir 22. Albany, NY.
- Geo-Access- Dutchess County Web Mapping (<http://geoaccess.co.dutchess.ny.us/geoaccessv2/>) September 21, 2021.

- Hart, J. P., and H. J. Brumbach.  
2005. Cooking Residues, AMS Dates, and the Middle-to-Late Woodland Transition in Central New York. *Northeast Anthropology* 69:1–34.
- Hasbrouck, Frank. Ed.  
1909 *The History of Dutchess County, New York*. S. A. Matthieu: Hyde Park, NY.
- Haviland, Jim  
1996 “Plans Underway for Shift in Sept”. Poughkeepsie Journal. 26 Dec 1996. Accessed at Newspapers.com.
- Küchler, August W.  
1964 *Potential Natural Vegetation of the Conterminous United States*. American Geographical Society, New York.
- Lavin, L., F. Gudrian and L. Miroff.  
1993 Prehistoric Pottery from the Morgan Site, Rocky Hill, Connecticut. *Bulletin of the Archaeological Society of Connecticut* 56:63–100.
- MacCracken, Henry Noble  
1956 *Old Dutchess Forever*. Hasting House Publishers, New York.
- Morse, Howard  
1908 *Historic Old Rhinebeck echoes of two centuries A Hudson River and Post Road Colonial Town*. Self-published, Rhinebeck, NY.
- Natural Resources Conservation Service  
[www.websoilsurvey](http://www.websoilsurvey). March 22, 2022.
- New York State Archaeological Council (NYAC)  
1994 *Standards for Cultural Resource Investigations and the Curation of Archaeological Collections in New York State*. New York Archaeological Council.
- New York State Office of Parks Recreation and Historic Preservation CRIS  
[cris.parks.ny.gov](http://cris.parks.ny.gov) Web Accessed March 30, 2022.
- Parker, Arthur  
1920 *Archaeological History of New York*. New York State Museum Bulletin. No. 237 and 238. The University of the State of New York: Albany, NY.
- Pierson, William H., Jr.  
1970 *American Buildings and Their Architects: The Colonial and Neo-Classical Styles*. Doubleday: New York, N. Y.
- Pretola, J.P. & J.A. Freedman  
2009 *Management Summary: Phase III Data Recovery Black Dirt Deep Testing, Towns of Minisink & Warwick, Orange County, New York*. Submitted to the Federal Agency Regulatory Commission, Docket # CP98-150-000, OPRHP # 04PR02896 by Gray & Pape, Inc., Providence, RI
- Poughkeepsie Eagle News  
1939a “Four Neighbor Companies go to Village Aid”. 21 Apr 1939. Accessed at Newspapers.com.  
1939b “Architect Engaged for Rhinebeck School.” 2 Jun 1939. Accessed at Newspapers.com.  
1938 “Voters in Rhinebeck Reject Playground.” 27 Sept 1938. Accessed at Newspapers.com.
- Poughkeepsie Journal  
1963 “Rhinebeck Slates School Space Talks”. 18 Dec 1963. Accessed at Newspapers.com

- 1952 "Rhinebeck to Move Soon to New Building. 26 Mat 1952. Accessed at Newspapers.com.  
 1949 "Rhinebeck School Plan indicates 1 Million Cost." 13 Jan 1949. Accessed at Newspapers.com.  
 1948 "Rhinebeck Beats School Project." 23 Oct 1948. Accessed at Newspapers.com.
- Reynolds, Helen Wilkenson  
 1938 *The Role of Plant Life in the History of Dutchess County*. Hyde Park: NY.
- Ritchie, William A.  
 1969 *The Archaeology of New York State*. Natural History Press: Garden City, NY.
- Ritchie, William A. and Robert Funk  
 1973 *Aboriginal Settlement Patterns in the Northeast*. Memoir 20. New York State Museum and Science Service. Albany, NY.
- Rhinevault, Carney  
 2009 Town of Rhinebeck History. <http://www.hydeparkny.us/Community/>.
- Salomon, Julian H.  
 1983 "Munsee and Mahican: Indians of Dutchess County." Dutchess County Historical Society Yearbook: 68. Hyde Park: NY.
- Shaver, Peter (compiler)  
 1992 *The National Register of Historic Places in New York State*. Preservation League of New York State: Albany, NY.
- Sidney, J.C.  
 1850 *Map of Dutchess County, New York from Original Surveys*. Gillette, Philadelphia, Pennsylvania.
- Smith, James H.  
 1882 *History of Dutchess County, New York*. D. Mason & Co.: Syracuse, NY.
- Smith, Philip H  
 1877 *General History of Dutchess County from 1609 to 1876*. Pawling, New York.
- Snow, Dean R.  
 1980 *The Archaeology of New England*. Academic Press: New York, NY.
- Spectra Inc.  
 2004 Draft Generic Environmental Impact Statement (Dgeis) New York State Statewide Wireless Network (Swn) Geologic Resources Appendix C: Geologic, Structural and Topographic Features of Physiographic Provinces.
- Stilgoe, John R.  
 1982 *Common Landscape of America, 1580-1845*. Yale University Press: New Haven, CT.
- United States Office of Agriculture  
 1981 *Soil Survey of Dutchess County, New York*. In cooperation with Cornell University Agricultural Experimentation Station. U.S. Government Printing Office. Washington D.C.
- United States Geological Survey  
 2019 United State Geological Survey Topographical Map. Kingston East, NY Quadrangle. 7.5 Minute Series.  
 1963 United State Geological Survey Topographical Map. Kingston East, NY Quadrangle. 7.5 Minute Series.



APPENDIX A: SHOVEL TEST RECORDS

TR	ST	Level	Depth (in)	Depth (cm)	Munsell	Soil Description	Cultural Material
1	1	1	0-9	0-22	10YR 4/3	Brown gravelly silt loam	NCM
		2	9-13	22-32	10YR 4/6	Dark yellowish brown gravelly silt loam	NCM
	2	1	0-10	0-25	10YR 4/3	Brown gravelly silt loam	NCM
		2	10-15	25-39	10YR 4/6	Dark yellowish brown gravelly silt loam	NCM
	3	1	0-11	0-28	10YR 4/3	Brown gravelly silt loam	NCM
		2	11-16	28-40	10YR 4/6	Dark yellowish brown gravelly silt loam	NCM
	4	1	0-7	0-18	10YR 4/3	Brown gravelly loam	NCM
		2	7-11	18-29	10YR 3/3	Dark brown gravelly loam	NCM
		3	11-16	29-40	10YR 5/6	Yellowish brown packed gravel and clay	NCM
	5					Not Excavated - Sidewalk Grading	
2	6	1	0-11	0-27	10YR 4/3	Brown gravelly silt loam	Plastic discarded
		2	11-15	27-39	10YR 4/6	Dark yellowish brown gravelly silt loam	NCM
	7	1	0-13	0-34	10YR 4/3	Brown gravelly silt loam	NCM
		2	13-18	34-46	10YR 4/6	Dark yellowish brown gravelly silt loam	NCM
	8	1	0-10	0-26	10YR 4/3	Brown gravelly silt loam, Stopped by large flat stone.	Brick fragments, window glass, coal and coal slag
	9	1	0-13	0-32	10YR 4/3	Brown gravelly silt loam	Coal, coal slag discarded
		2	13-18	32-45	10YR 4/6	Dark yellowish brown gravelly silt loam	NCM
3	10	1	0-7	0-18	7.5YR 4/4	Brown sandy loam	NCM
		2	7-12	18-30	10YR 3/2	Very dark grayish brown sandy clay loam with dense gravel	NCM
		3	12-16	30-40	10YR 4/6	Dark yellowish brown coarse sand and gravel	NCM
4	11	1	0-17	0-42	10YR 3/3	Dark brown sandy clay loam with gravel	Nail, coal and brick fragments discarded
		2	17-22	42-56	10YR 4/6	Dark yellowish brown clay loam with gravel	NCM
	12	1				Not Excavated - Playground	

TR	ST	Level	Depth (in)	Depth (cm)	Munsell	Soil Description	Cultural Material
	13	1	0-9	0-22	10YR 3/2	Very dark grayish brown gravelly silty clay loam	NCM
		2	9-11	22-28		Coal and Ash Layer	Coal, coal slag and ash discarded
		3	11-15	28-38	10YR 4/6	Dark yellowish brown sandy clay with gravel	NCM
	14	1	0-14	0-35	10YR 3/3	Dark brown coarse sand and gravel, Stopped by concrete	Brick fragments, window glass and coal discarded
	15	1	0-4	0-11	10YR 3/3	Dark brown gravelly silty clay loam	NCM
		2	4-16	11-30	10YR 4/6	Dark yellowish brown packed gravel and clay	NCM
5	16	1	0-12	0-31	10YR 4/3 & 4/6	Mixed brown and Dark yellowish brown gravelly silt loam	Metal and coal discarded
		2	12-17	31-44		Coal and Ash Layer	Coal, coal slag and slag discarded
		3	17-22	44-57	10YR 4/6	Dark yellowish brown gravelly clay	NCM
	17	1	0-19	0-47	10YR 3/3 & 4/6	Mixed dark brown and dark yellowish brown gravelly sandy loam	Brick, coal, coal slag, slag, window glass discarded
		2	19-25	47-63	2.5Y 4/2	Dark grayish brown coarse sand and gravel. Stopped by rock	NCM